

ECE 437 LAB 5: AM Broadcast Experiment

OBJECTIVES:

To prototype an AM radio. Measurements will be in the form of oscilloscope screenshots. The lab report should contain some quantitative and qualitative analysis on these screenshots. Altogether, this lab is light on measurements and is more of a demonstration.

Introduction:

In this lab measurements will be done on a modulator device to find its parameters. An amplifier circuit will allow sound to be modulated by the device. An RC envelope detector will be used to demodulate the signal. Finally, some simple antennas will broadcast the signal a short distance, and a simple receiver will be tested.

Equipment Used:

1. Two small breadboards provided by the students
2. Function generator with AM input
3. One oscilloscope at the lab station, plus another oscilloscope at another location.
4. Dual power supply (both set to 5V and limited to less than 50mA if possible)
5. Set of amplified computer speakers (optional)

Components Used:

1. One LM324 Quad Op-Amp (only two op-amps are used). Can also use TWO 741 Op-Amp ICs.
2. Various resistors (from 100ohms to 1megaohm)
3. Various capacitors (from 100pF to 100uF)
4. One Inductor (around 50uH to 500uH)
5. One Germanium diode (such as a 1N4148)
6. One BNC T-adaptor
7. Banana wires
8. BNC-to-BNC cables
9. BNC-to-Banana cables

EXPERIMENTAL PROCEDURES:

Pre-Lab:

Design the RC portion in **Fig. 1**. The Resistor Value Should be at least 1Kohm, but no more than 200Kohm. Use the following equation to determine the value of R.

$$\tau = RC \text{ and } \tau \gg \frac{1}{f_c}$$

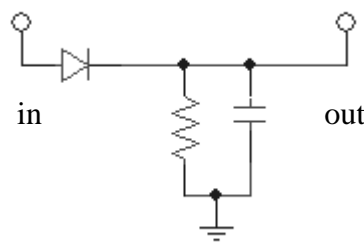

Fig. 1: Envelope Detector

Design the LC circuit in **Fig. 2**. The inductor value should be between 50uH and 500uH. The Resonant frequency should be between 1MHz and 3MHz. Use the following equation for the calculation.

$$f = \frac{1}{2\pi\sqrt{LC}}$$

Optional online reading includes the LM324 or UA741 data sheet.

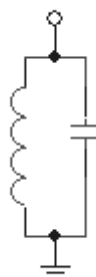

Fig. 2: LC Circuit

Lab Part 1: Audio Amplitude Modulation Setup.

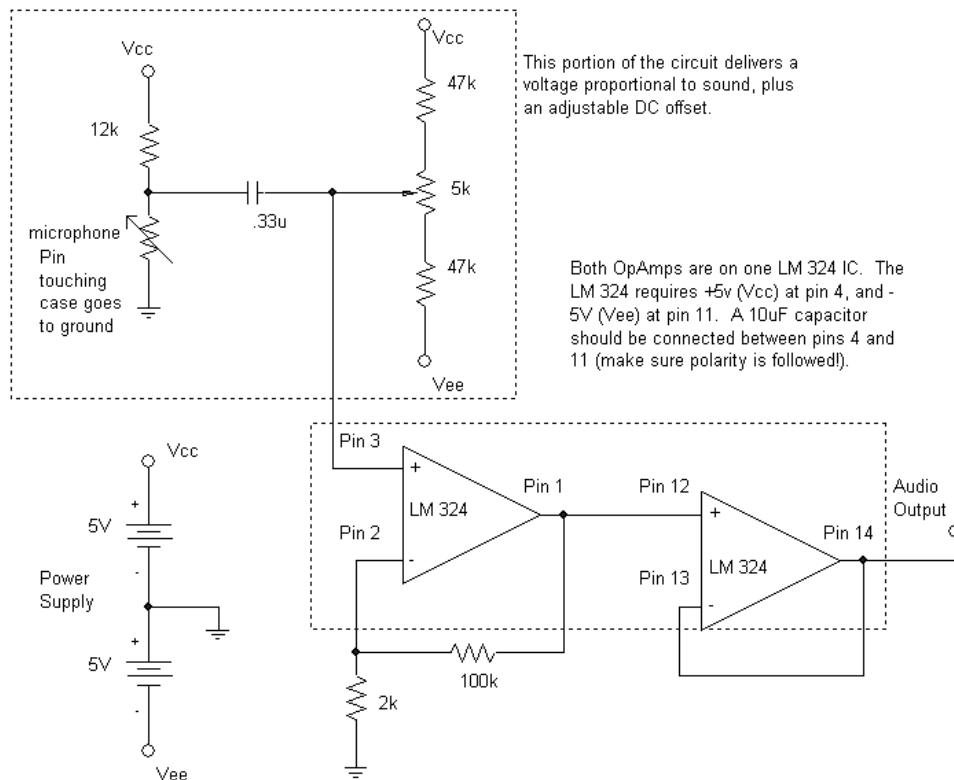

Fig. 3: Amplifier Circuit

1. Construct the circuit in **Fig. 3**.
2. Set the oscilloscope at the lab station to have Channel 1 and Channel 2.
3. Connect the Audio Output to Channel 1 of the oscilloscope. For the audio output, use a single tone signal from a signal generator with a frequency of 1kHz (200mVp-p). You should see the amplified signal from the microphone, plus a DC offset. Adjusting the potentiometer will change the DC offset. Reduce DC offset to ZERO.
4. Connect the Audio Output to the AM input of the function generator (found on the back of the Tektronix CFG 280). Set the function generator to sine wave, about 200KHz, and amplitude of 5Vp-p.

Helpful Hint:

Autoset tries to lock onto a continuous signal. It won't work well with audio, which is mostly transient. Furthermore, it could adjust to the period of the modulating waves, which will not properly show the audio.

5. Connect function generator output (modulated signal) to Channel 2 of the Oscilloscope. AM signal is now displayed on Channel 2.
6. Observe the AM signal spectrum on a spectrum analyzer, and measurement of its bandwidth.

Lab Part 2: Transmission Setup.

1. Referring to **Fig.4** for the antenna layout. Use the BNC T-way on the function generator output (AM signal). Connect one cable from the T to Channel 1.
2. Attach a BNC-to-Banana cable to the T. Extend the red portion by adding another 2-4 foot long Banana cable to it.
3. Clip the long Banana cable to one leg of a 1nF capacitor. String the cable horizontally along the lab bench(s). Connect the other leg of the capacitor to the ground terminal of a power supply. You have just built a simple antenna.

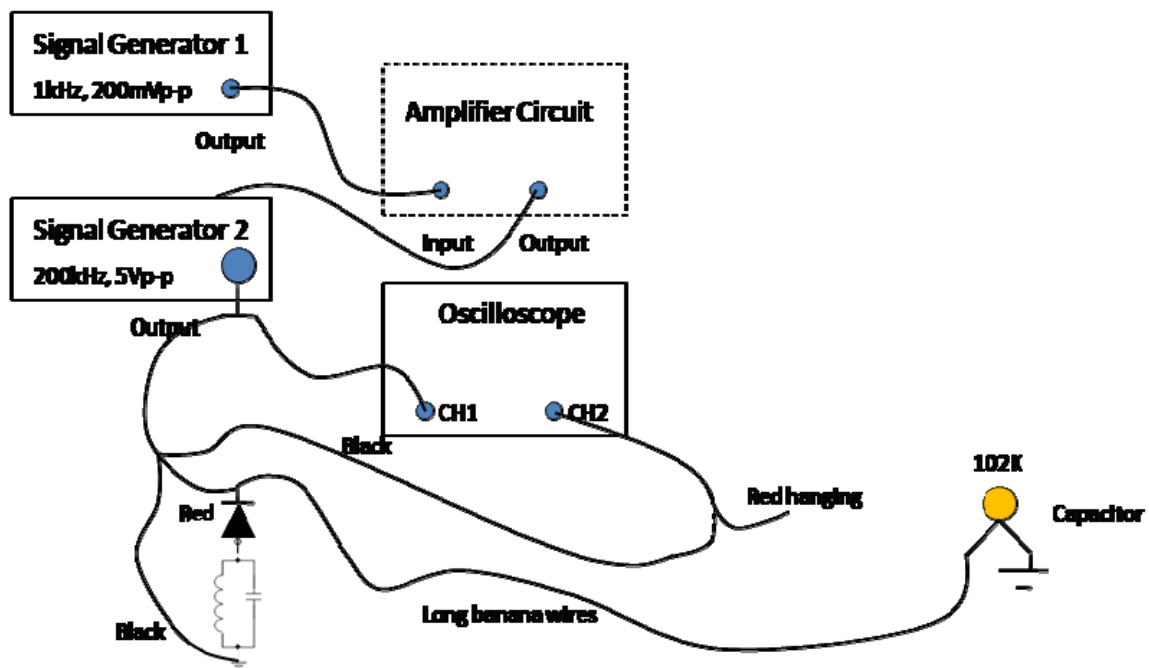

Fig. 4: Antenna Layout.

Lab Part 3: Reception Setup.

1. Build the LC circuit in **Fig. 2**. Use the LC values found in the Pre-Lab. Place it by the other oscilloscope.
2. Attach a long wire to the top of the LC circuit. Lay the wire horizontally, along the same direction as the long Banana cable.
3. Attach the anode end of a Germanium diode to the top end of the LC circuit. Attach the cathode end to the red banana of a BNC-to-Banana cable.
4. Attach the black banana to the ground of the LC circuit. Plug the BNC into the oscilloscope (CH2), which will now display your received and modulated signal! The cable and scope act as a 1 megaohm resistor in parallel with several picofarads. Refer to **Fig. 4** for the circuit layout. If the receiver signal is too weak, design an amplifier circuit such as in **Fig. 3** that has a gain of few hundreds. Connect the amplifier from the receiver antenna before connecting it to oscilloscope CH2.
5. Slowly change the frequency of the function generator, from 200KHz to 5MHz. Look for the DC level to rise on the received signal. Stop when the DC level is highest. Your receiver is now tuned in.
6. Try varying the frequency of the message signal and observe its response on the oscilloscope.
7. Observe the AM signal spectrum on a spectrum analyzer, and measurement of its bandwidth.
8. **(Optional)** Connect the plug of the amplifier computer speakers to the receiver circuit. The ground of the plug (see **Fig. 5**) should go to the ground of the circuit. The left or right (your choice) of the plug should go to the cathode of the germanium diode. The signal level observed on the oscilloscope will drop (more power is being consumed). Turn the speaker volume up, talk into the microphone, and listen to the broadcast AM radio being produced!

Helpful Hint:

The stray capacitances and inductances on your circuit and cabling affect your circuit performance. The tuned frequency will be different than what you calculated for the LC circuit.

Helpful Hint:

Antenna design can rely a lot on feeling out the design and testing out prototypes. The long wires are not very long compared to the wavelength. The 1 nF capacitor helps draw in more current into the “short” transmitting antenna, improving its broadcast power.

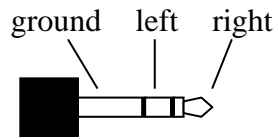

Fig. 4: Stereo Plug

Lab Part 4: Envelope Detection.

1. Build the envelope detector in **Fig. 1**. Use a Germanium diode and the RC values found in the Pre-lab.
2. Connect the modulated signal to the envelope detector input. Connect oscilloscope Channel 2 to the output. Channel 1 should now display the original audio signal, and Channel 2 should show the reconstruction of the signal.
3. Vary the frequency of the message signal. Take a few oscilloscope screenshot.