

OBJECTIVES:

1. To study the basic principles of amplitude modulation.
2. To investigate different modulation techniques.

Instructor Use:

This AM board has been designed to produce AM modulation and synchronous detection with very easy setup. There are several parameters that you should be aware of:

Standard Carrier Features (board powered by 20V)

- 100KHz carrier frequency generated on board
- Carrier amplitude of 3.25V

Standard carrier frequency and amplitude can be adjusted, if necessary, using pots R3 and R10.

The AD633 multipliers have a bandwidth of 1MHz. A carrier of 100 KHz was chosen to ensure that several harmonics of the AM wave would be visible, allowing for triangle, and square modulating waves to be used.

Amplitude Features (board powered by 20V)

- Modulating signal amplitude range of -6V to 6V
- AM signal amplitude is approximately 2/3 of modulating signal amplitude
- Synchronous detection amplitude is approximately 1/3 of modulating signal amplitude

-6V to 6V is the total input amplitude range. The peak-to-peak amplitude of the modulating signal should be less than 6V, to allow for DC offset.

Having the AM and Synchronous detection amplitudes lower than the modulating signal amplitude allows the scope to clearly display both with the same scale settings. A carrier amplitude of 3.25 V achieves this.

Advanced Features

- Use of alternative carrier
- Use of alternative synchronous detection signal

To use the alternative carrier, set switch S1 to the right position and connect another function generator to BNC 7.

To use the alternative synchronous detection signal, set switch S2 to the right position, and connect another function generator to BNC 6.

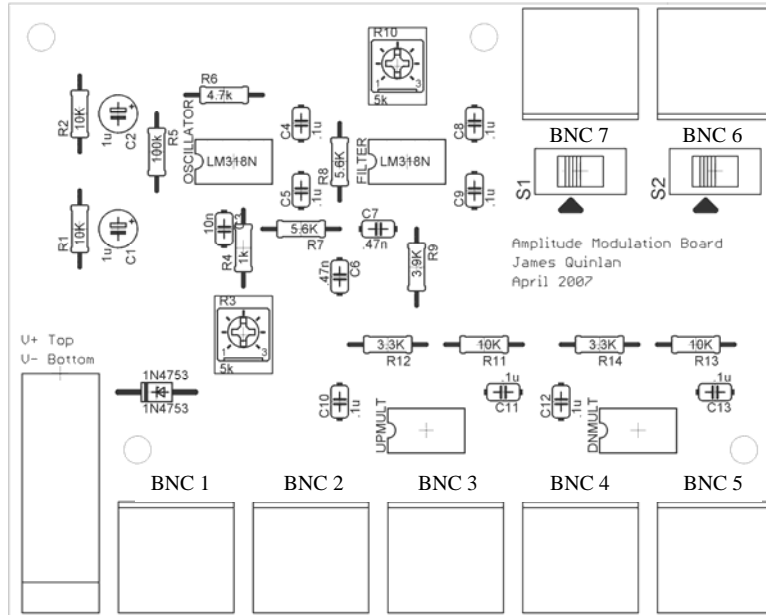
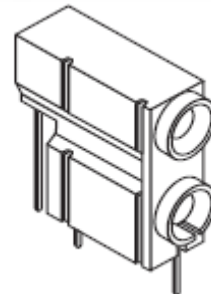

Figure 1: Amplitude Modulation Board

EXPERIMENTAL PROCEDURES:

Experiment A: (*Amplitude Modulation*)

1. Make sure that the switches S1 and S2 on the board are to the left (triangle) position.
2. Attach a BNC cable from BNC 1 on the AM board to Channel 1 on the oscilloscope. Turn on the oscilloscope.
3. Connect a power supply to the double banana connector on the AM board. The positive voltage should go to the top connector, and the negative voltage should go to the bottom connector.



The AM board has a voltage divider that splits the single voltage into two separate voltages to allow waveforms that go both positive and negative.

- Turn on the power supply, and turn up the voltage to 20V. The oscilloscope should show a 100 KHz sine wave. This is your carrier wave.

The AM board has an oscillator circuit that generates the 100 KHz sine wave.

- Disconnect the oscilloscope from the BNC 1, and connect it to BNC 2. Oscilloscope Channel 1 now shows the modulating signal, which is currently zero.

The modulating signal is zero because the modulating signal is not produced by the board.

- Connect a function generator output to BNC 3. Turn on the function generator.
- Adjust the function generator until the modulating signal on Channel is the same frequency, waveshape, amplitude, and DC offset as requested by your instructor.
- Connect oscilloscope Channel 2 to BNC 4 on the board. Channel 2 should now show the AM signal on the oscilloscope, with Channel 1 being the corresponding modulating signal. Take a picture of the oscilloscope screen.

If the modulating signal has no DC offset, then the AM signal is DSB-SC.

- Now introduce a DC offset into the message signal to obtain DSB with carrier. Take a picture of the oscilloscope screen.
- Try a variety of different DC offset values on the message signal. For each, calculate the modulation index μ using the formula in the text. To measure μ , place the oscilloscope in XY mode, so the screen looks something like Figure 2.
- The modulation index may then be calculated from the above screen by the relation

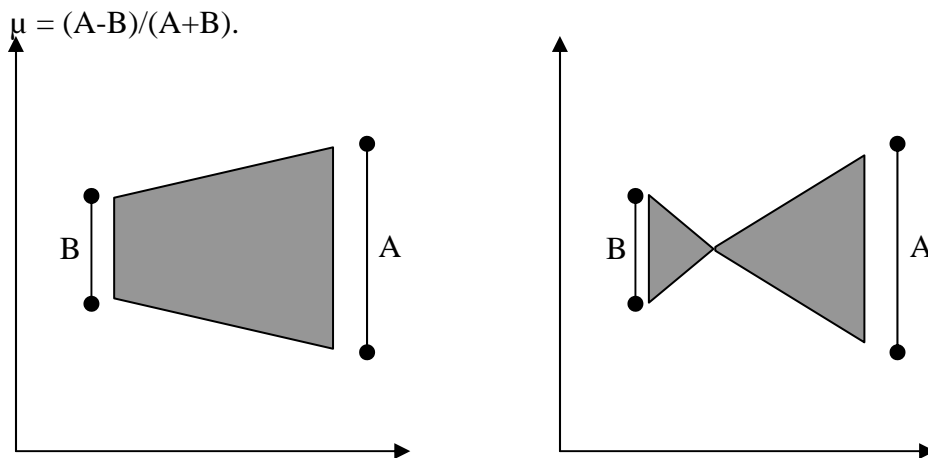

Figure 2: Different Modulation Indices of AM

Experiment B: (Demodulation of the AM signal – Synchronous Detection)

1. Disconnect Channel 2 from BNC 4, and connect it to BNC 5. Channel 2 now shows the synchronous detector output, while Channel 1 shows the corresponding modulating signal.

The AM board has two analog multipliers on it. The first one generates the AM, and the second one generates the synchronous detection.

2. Design an active low pass filter and connect it to the output of the synchronous detection board (Select filter cutoff frequency of the filter to be Hz). Verify your filter design using PSpice before building the actual circuit.
3. Disconnect Channel 2 from BNC 5 and connect it to the output of the filter. The scope now shows the modulating signal as it was originally and after it has been modulated and demodulated. Take a picture.
4. Try to explain (qualitatively and mathematically) why the demodulated signal looks the way it does.

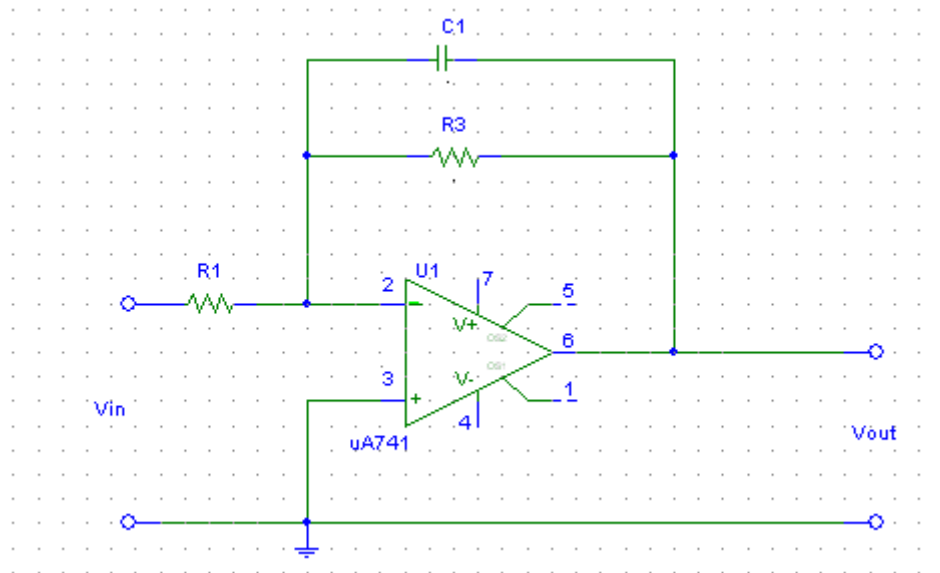

Figure 3: Active Low Pass Filter Circuit

Experiment C: (Demodulation of the AM signal – Envelope Detection)

1. Build the envelope detector circuit shown in figure 4. The diode is IN4148.
2. Connect the AM output of the AM board, BNC 4, to the input of the envelope detector.
Note: Only the DSB with carrier is to be used in this portion of the experiment.
3. Display the original message and the envelope detector output simultaneously on the oscilloscope. Take a picture of the oscilloscope screen.
4. Observe (as indicated in the step 3 above) the performance of the envelope detector for three different modulation indices: $\mu = 0.5, 1.0, 1.5$ and 2.0 . Indicate in each of the cases whether the condition for envelope detection was met and discuss.

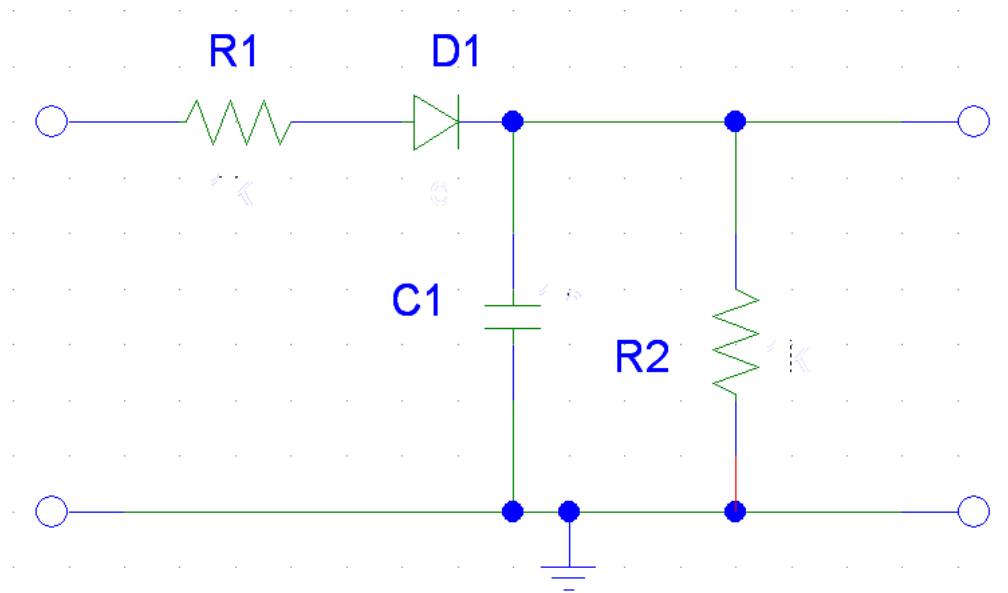

Figure 4: Envelope Detector Circuit.