



**COMMUNICATION SYSTEMS (ECE 437)  
LABORATORY MANUAL**

**EXPERIMENT 2**

**School of Engineering and Computer Science  
Oakland University**

## LAB NO.: 2 [Active Filter Design]

### OBJECTIVES:

1. To design active Low Pass, High Pass and Band Pass filters.
2. To observe and analyze the effects of filtering on different waveforms.

### EXPERIMENTAL PROCEDURES:

1. Derive the transfer function  $V_{out}(s) / V_{in}(s)$  of the low pass and the high pass filter circuits shown in **Figures 1** and **2**, respectively.
2. Design a first order low pass filter with pass band gain of about 10 dB and -3 dB cut-off frequency at 10 KHz. Plot the frequency response function of the filter using **PSpice** or **Matlab** to verify your design. Build the filter circuit, measure and plot its frequency response function.
3. Apply a square wave to the input of the low pass filter designed in **Part 2** above. To start with, choose a frequency somewhat lower than the cut-off frequency of the filter, and as you increase the frequency towards the cut-off frequency of the filter, observe the output of the filter in the oscilloscope. Analyze and explain your findings.
4. Design and build a first order high pass filter with a pass band gain of 6 dB and a -3dB cut-off frequency of 1 KHz. Plot the frequency response function of the filter using **PSpice** or **Matlab** to verify your design. Build the filter circuit, measure and plot its frequency response function.
5. Cascade the filters constructed in **part 2** and **part 4** above to create a band-pass filter with pass band between 1 KHz and 10 KHz. Plot the frequency response function of the filter in Matlab to verify your design. Build the filter circuit, measure and plot its frequency response function.

6. Please answer the following questions:

- a. Consider the low-pass filter designed in **part 2** above. Suppose we want to normalize the dc gain of the filter to 0 dB. How would you modify your circuit to achieve the same?
- b. Consider once again the low-pass filter designed in **part 2** above. Suppose the edge of the stop band is assumed to start at a frequency where filter gain is 10 dB below its dc gain. Find the width of the transition band of your filter.
- c. If you are asked to design a low-pass filter with a narrower transition band, how would you achieve it?
- d. Outline a technique similar to **Part 5** above that can be used to design a band-reject a filter with a pass band between 5 and 15 KHz.
- e. As you know, filters can be either passive or active. For instance, you had designed a passive band-pass filter in **Lab #1**, whereas in **part 5** of this lab you designed an active one. Similar observations are also valid for other types of filters. What do you think are the advantages of an active filter as compared to a passive one?

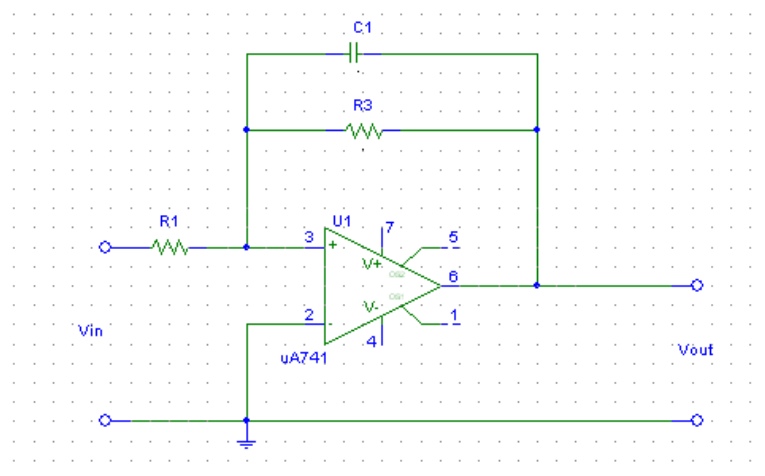

Figure 1: Low Pass Filter

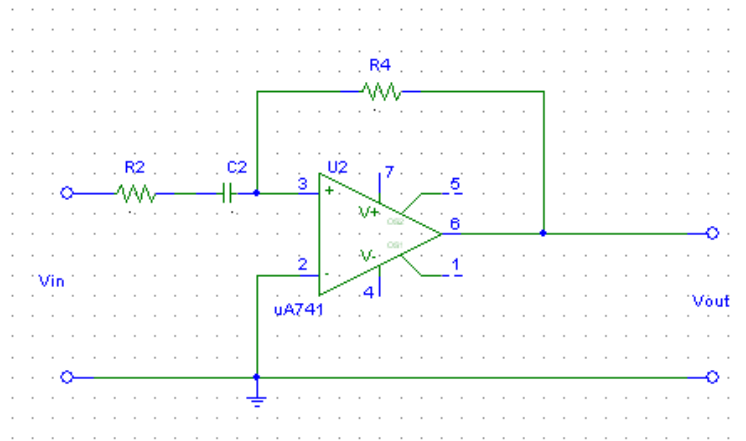

Figure 2: High Pass Filter