

Final Exam, Part (2)

A belt conveyor is used to transmit cement from one stage to another in a cement factory. The capacity of this conveyor is 10 packing cases (each of 50 kgm) at a linear velocity of 1 m/s. The diameter of the conveyor drum is 200 mm.

The conveyor is driven using an electric motor running at 1120 RPM. Two stages are used to reduce the motor speed of 1120 RPM to the conveyor drum speed in order to achieve the linear velocity of 1m/s. The first stage is a V-Belt drive and the second stage is a Spur Gear drive as shown in Figure.

The coefficient of friction between belt and pulleys is ($\mu_v = 0.35$).

Requirements:

1. Make a complete design of the first stage using V-Belt. 35%
2. Make a preliminary design of the second stage using spur gears.
 (The checks on bending fatigue and the surface failure are not required) 25%
3. Find the diameter of Shaft(2). 15%
 Shaft (2) holds the large pulley, and the pinion.
4. Select proper deep Groove ball bearings for shaft(2). 15%
 (Both bearings are identical).
5. Draw a free hand sketch of shaft(2) showing, the fixation of the pinion and the large pulley on the shaft, and the ball bearings. 10%

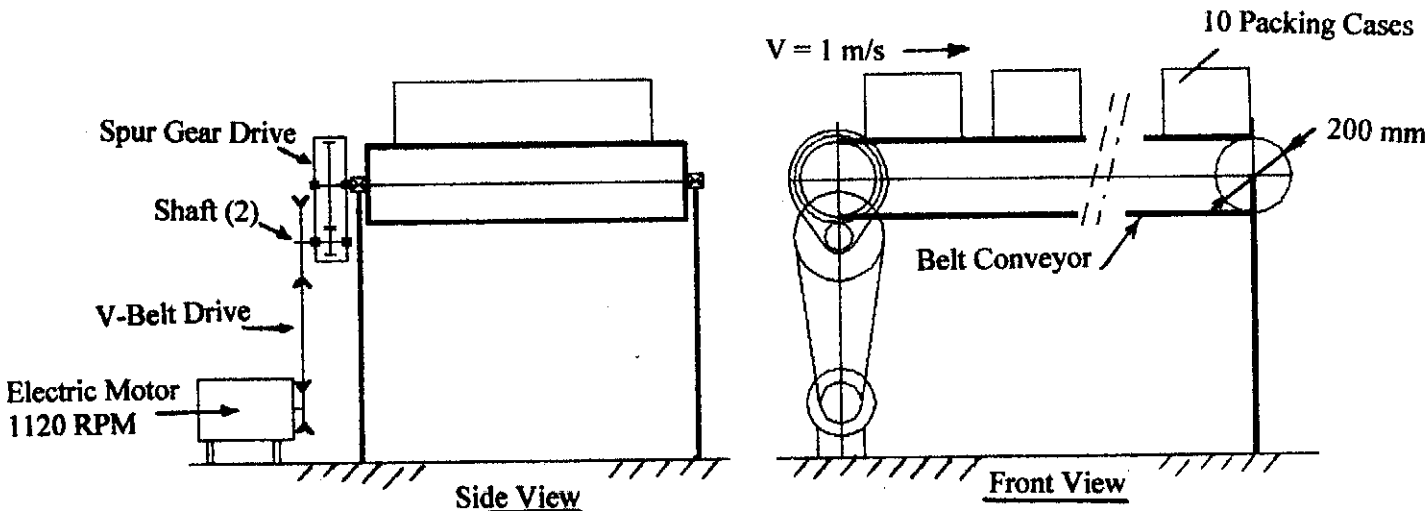

Assume any missing data