

EXPERIMENT 3M1: Measuring Linear Rate on a Conveyor Belt

Objectives

- A. Find the linear speed of a conveyor belt.
- B. Find the production rate of a conveyor belt.

Key Concepts

Linear speed -- a measure of how fast an object moves in a straight line (such as on a conveyor belt). The mathematical formula may be expressed as:

$$\text{Distance} = \text{rate} \times \text{time} \quad \text{or} \quad \begin{array}{c} \triangle \\ \text{D} \\ \hline \text{r} \quad \text{t} \\ \triangle \end{array}$$

$$\text{cm} = \frac{\text{cm}}{\text{sec}} \times \text{sec}$$

Production rate -- a count of the number units (objects) produced in a given period of time. The mathematical formula may be expressed as:

$$\# \text{ of units delivered} = \text{production rate} \times \text{time}$$

If the units can be measured as mass the formula may be expressed as:

$$\text{mass delivered} = \text{rate} \times \text{time} \quad \text{or} \quad \begin{array}{c} \triangle \\ \text{g} \\ \hline \text{r} \quad \text{t} \\ \triangle \end{array}$$

$$\text{g} = \frac{\text{g}}{\text{sec}} \times \text{sec}$$

Procedure

Set up the equipment as is indicated in the diagram below. Power should be

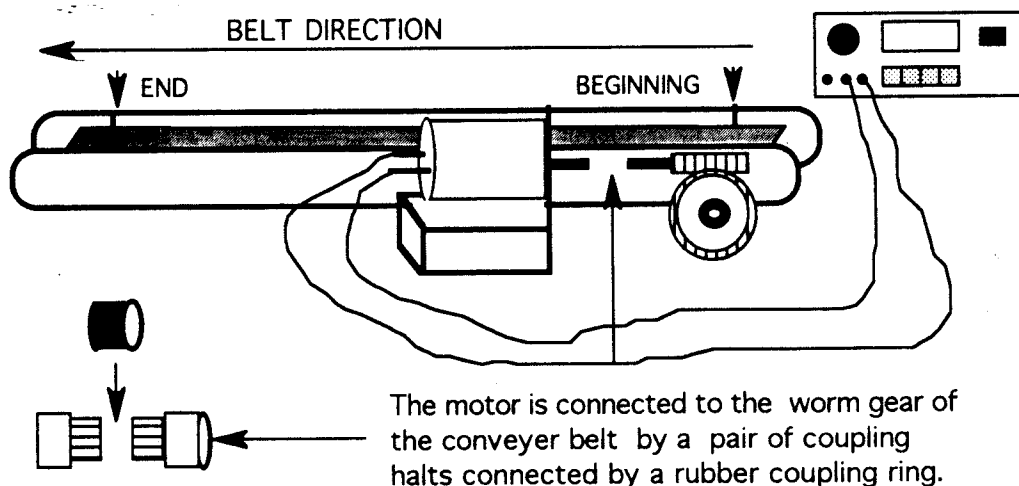

1. Be sure the voltage control knob is turned off. Turn on the power supply.
2. Mark on the side structure of the conveyor belt the beginning and the end of the runs you will be conducting. Measure the length in centimeters and record in Data Table 1.
3. Slowly turn up the voltage. The motor should run smoothly and easily. The equipment should not bind (get stuck). Call the instructor if there appear be problems.
4. Record 3 voltages that correspond to slow, medium and fast and record in Data Table 1. Do no drive the system to hard!

Linear rate

1. Adjust the voltage to the slow setting and turn off the power supply.
2. Place a nut at the beginning mark. Turn on the power and time the period from the beginning to end. Record in Data Table 1.
3. Repeat for the medium and high speeds.
4. Calculate rate for each of the three settings and record in Data Table 1.

Distance = rate X time or

$$\text{cm} = \frac{\text{cm}}{\text{sec}} \times \text{sec}$$

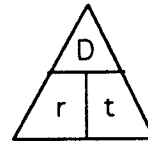

Data Table1: Linear Rate

Speed Setting	Voltage Setting (V)	Distance (cm)	Time (sec)	Linear Speed D/t
Slow				
Medium				
Fast				

Production rate in grams pers second

1. Weigh the nuts on the triple beam balance and record in Data Table 2.
2. Count the numberof nuts you have and record in Data Table 2.
3. Distribute the nuts between the beginning and ending marks on the conveyer belt.
4. Set the voltage to slow. Time how long it takes for the conveyer belt to carry all the nuts to the end. Record in Data Table 2.
5. Repeat for the medium and fast settings.

6. Calculate the production rate in units and record in Data Table 2.

$$\text{No. of units produced} = \text{Total No. of units/time}$$

7. Calculate the production rate in grams and record in Data Table 2.

$$\text{No. of grams produced} = \text{Total No. of grams/time}$$

Data Table2: Production Rate

Speed Setting	Voltage Setting(V)	No. of Bolts	Total Mass(g)	Unit Rate (units/sec)	Mass Rate (g/sec)
Slow					
Medium					
Fast					

Questions

1. How does the production rate depend on the voltage applied? _____

2. How does the production rate depend on the number of units? _____

3. List some ways in which production rate can be increased. _____
