

Problem sheet- PS 02 (Translating and rotating containers)

1. Consider an open rectangular container of length 'L', height 'H' and width 'w' into the paper initially filled with a liquid upto height 'h' ($h < H$). If the tank is placed on a cart and accelerated on a level road with an acceleration 'a' as shown in fig. 1. Determine
 - a) Critical accn ' a_c ' that just prevents spilling of liquid as a function of (h / H) for $h / H > \frac{1}{2}$
 - b) Critical accn ' a_c ' that just prevents spilling of liquid as a function of (h / H) for $h / H < \frac{1}{2}$
 - c) Plot the critical accn ' a_c ' for the entire range of $0 < (h / H) < 1.0$.
 - d) The accn ' a_1 ' that causes the point C to be exposed to the atmosphere for $h / H > \frac{1}{2}$
 - e) The accn ' a_1 ' that causes the point C to be exposed to the atmosphere for $h / H < \frac{1}{2}$

2. For the above Prob. 1 if the acceleration 'a' exceeds ' a_c ' then some amount of liquid would be spilled out. Determine
 - a) The fraction of volume spilled 'f' as a function of (a / a_c) and (h / H) for $h / H > \frac{1}{2}$
 - b) For $h / H < \frac{1}{2}$, show that the fraction of volume spilled 'f' is a function of (a / a_c) only.

3. Consider the cart shown in fig. 2 filled with water. The cart is accelerated to the right by a magnitude ' $g/5$ ' m/s^2 . Compute the forces on the surfaces AB, BC and CD after the acceleration has been imparted.

4. Consider the sealed water tank shown in fig. 3. The tank is 1m wide into the paper. Initially the tank is pressurized and both the gauges A and B read 20 KPa. The tank is suddenly accelerated so that Gauge A reads 17.5 KPa and B reads 22.5 KPa. At the bottom of the tank a balloon of diameter 10 cm, filled with air (press = 130 KPa, Temp = 20^0C) is attached to the base with a string as shown in fig. 3. Determine
 - a) The direction and magnitude of the acceleration.
 - b) Whether the balloon will lean towards right or left? Also, obtain the angle of inclination of the string.
 - c) The tension in the string

5. Sometimes orientation can be very important. Consider the open rectangular container filled with oil (SG = 0.8) as shown in fig. 4. The container is to be placed on a trolley and transported on a straight road. If the trolley is capable of achieving accelerations of magnitude $3g / 5$, how should the tank be placed on the trolley so as to avoid spilling during the transport (Hint: determine which side of the tank should be aligned with the length of the trolley).

6. Consider an open rectangular container pushed up an inclined plane at an acceleration 'a' as shown in fig. 5. Determine the orientation ' θ ' with respect to the incline (fig. 5) for
 - a) $a = g \sin\phi$
 - b) $a = 0$
 - c) $a = - g \sin\phi$

7. Consider an open circular cylinder of radius 'R', height 'H' initially filled with some liquid to a height 'h'. If the cylinder is rotated about its axis (oriented along gravity) at a steady rotation rate ' ω ', determine
 - a) Critical speed ' ω_c ' that just prevents spilling of liquid as a function of (h / H) for $h / H > \frac{1}{2}$
 - b) Critical speed ' ω_c ' that just prevents spilling of liquid as a function of (h / H) for $h / H < \frac{1}{2}$

- c) Plot $(\omega_c)^2$ with (h / H) for the range $0 < (h / H) < 1.0$ and compare with the characteristic obtained in Prob 1(c).
 - d) The speed ω_1 that causes the center of the base to be just exposed to the atmosphere for $h / H > 1/2$
 - e) The speed ω_1 that causes the center of the base to be just exposed to the atmosphere for $h / H < 1/2$
8. For the above Prob. 7 if the rotational rate ω exceeds ω_c then some amount of liquid would be spilled out. Determine
- a) The fraction of volume spilled f as a function of $(\omega / \omega_c)^2$ and (h / H) for $h / H > 1/2$
 - b) For $h / H < 1/2$, show that the fraction of volume spilled f is a function of $(\omega / \omega_c)^2$ only.
 - c) Compare your results obtained in (a) and (b) with the analogous results in Prob 2(a) and 2(b).
9. Figure 6 shows a cylinder that is filled with water. With the cylinder stationary, the water is filled upto a certain height in the two tubes initially. The cylinder is then rotated about it's axis kept vertical and it is observed that the levels in the two tubes are as shown in fig. 6. Determine (i) the rotational speed of the cylinder in rpm and (ii) the nett pressure force on the cylinder base.

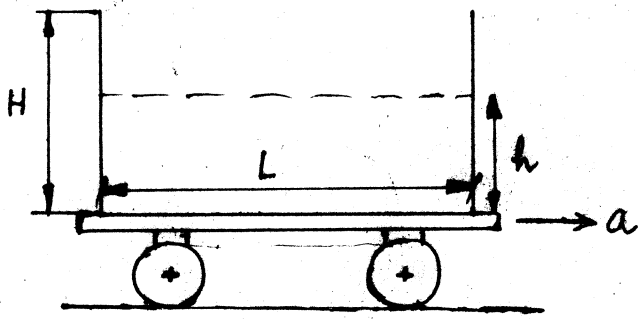

Fig. 1.

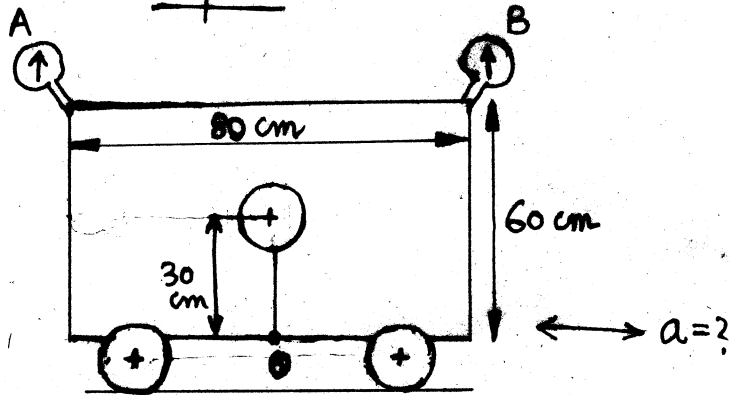

Fig. 3

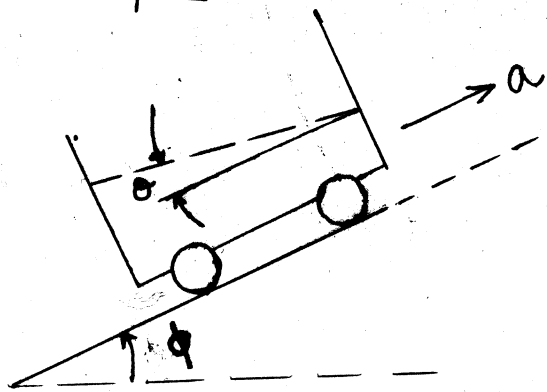

Fig. 5

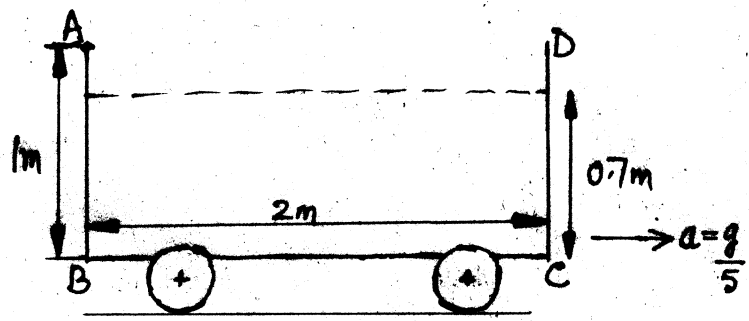

Fig. 2

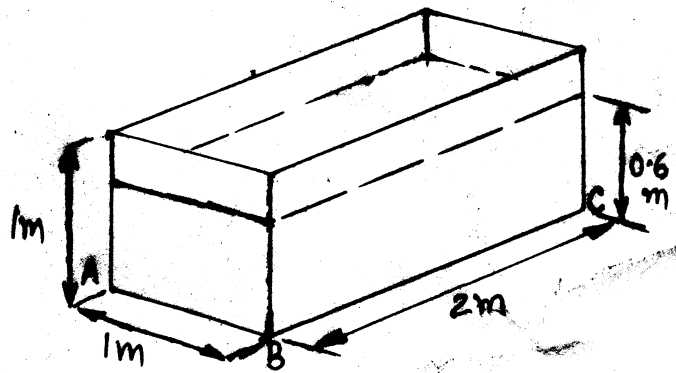

Fig. 4

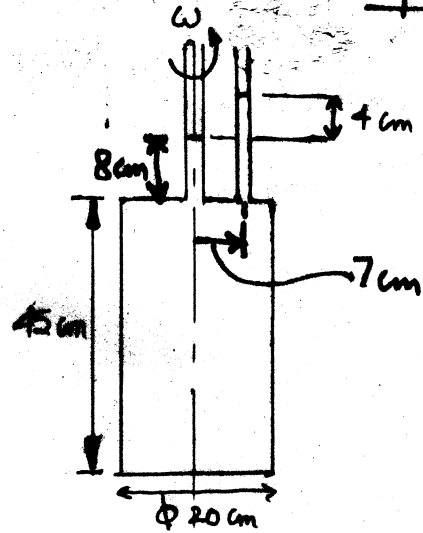

Fig. 6