

LM117/LM317A/LM317

3-Terminal Adjustable Regulator

General Description

The LM117 series of adjustable 3-terminal positive voltage regulators is capable of supplying in excess of 1.5A over a 1.2V to 37V output range. They are exceptionally easy to use and require only two external resistors to set the output voltage. Further, both line and load regulation are better than standard fixed regulators. Also, the LM117 is packaged in standard transistor packages which are easily mounted and handled.

In addition to higher performance than fixed regulators, the LM117 series offers full overload protection available only in IC's. Included on the chip are current limit, thermal overload protection and safe area protection. All overload protection circuitry remains fully functional even if the adjustment terminal is disconnected.

Normally, no capacitors are needed unless the device is situated more than 6 inches from the input filter capacitors in which case an input bypass is needed. An optional output capacitor can be added to improve transient response. The adjustment terminal can be bypassed to achieve very high ripple rejection ratios which are difficult to achieve with standard 3-terminal regulators.

Besides replacing fixed regulators, the LM117 is useful in a wide variety of other applications. Since the regulator is "floating" and sees only the input-to-output differential volt-

age, supplies of several hundred volts can be regulated as long as the maximum input to output differential is not exceeded, i.e., avoid short-circuiting the output.

Also, it makes an especially simple adjustable switching regulator, a programmable output regulator, or by connecting a fixed resistor between the adjustment pin and output, the LM117 can be used as a precision current regulator. Supplies with electronic shutdown can be achieved by clamping the adjustment terminal to ground which programs the output to 1.2V where most loads draw little current.

For applications requiring greater output current, see LM150 series (3A) and LM138 series (5A) data sheets. For the negative complement, see LM137 series data sheet.

Features

- Guaranteed 1% output voltage tolerance (LM317A)
- Guaranteed max. 0.01%/V line regulation (LM317A)
- Guaranteed max. 0.3% load regulation (LM117)
- Guaranteed 1.5A output current
- Adjustable output down to 1.2V
- Current limit constant with temperature
- P+ Product Enhancement tested
- 80 dB ripple rejection
- Output is short-circuit protected

Typical Applications

1.2V–25V Adjustable Regulator

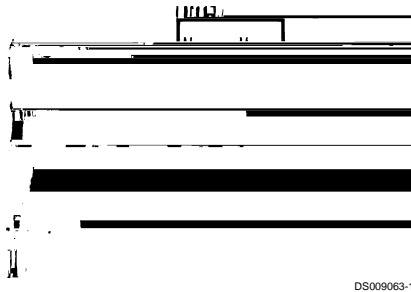

Full output current not available at high input-output voltages

*Needed if device is more than 6 inches from filter capacitors.

†Optional — improves transient response. Output capacitors in the range of 1 μ F to 1000 μ F of aluminum or tantalum electrolytic are commonly used to provide improved output impedance and rejection of transients.

$$\dagger\dagger V_{OUT} = 1.25V \left(1 + \frac{R_2}{R_1} \right) + I_{ADJ}(R_2)$$

LM117 Series Packages

Part Number Suffix	Package	Design Load Current
K	TO-3	1.5A
H	TO-39	0.5A
T	TO-220	1.5A
E	LCC	0.5A
S	TO-263	1.5A
EMP	SOT-223	1A
MDT	TO-252	0.5A

SOT-223 vs D-Pak (TO-252) Packages

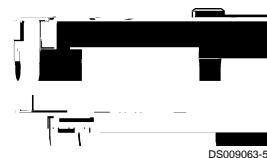

Scale 1:1

Absolute Maximum Ratings (Note 1)

If Military/Aerospace specified devices are required, please contact the National Semiconductor Sales Office/Distributors for availability and specifications.

Power Dissipation	Internally Limited
Input-Output Voltage Differential	+40V, -0.3V
Storage Temperature	-65°C to +150°C
Lead Temperature	
Metal Package (Soldering, 10 seconds)	300°C
Plastic Package (Soldering, 4 seconds)	260°C
ESD Tolerance (Note 5)	3 kV

Operating Temperature Range

LM117	-55°C ≤ T _J ≤ +150°C
LM317A	-40°C ≤ T _J ≤ +125°C
LM317	0°C ≤ T _J ≤ +125°C

Preconditioning

Thermal Limit Burn-In	All Devices 100%
-----------------------	------------------

Electrical Characteristics (Note 3)

Specifications with standard type face are for T_J = 25°C, and those with **boldface type** apply over full Operating Temperature Range. Unless otherwise specified, V_{IN} - V_{OUT} = 5V, and I_{OUT} = 10 mA.

Parameter	Conditions	LM117 (Note 2)			Units	
		Min	Typ	Max		
Reference Voltage					V	
	3V ≤ (V _{IN} - V _{OUT}) ≤ 40V, 10 mA ≤ I _{OUT} ≤ I _{MAX} , P ≤ P _{MAX}	1.20	1.25	1.30	V	
Line Regulation	3V ≤ (V _{IN} - V _{OUT}) ≤ 40V (Note 4)		0.01	0.02	%/V	
			0.02	0.05	%/V	
Load Regulation	10 mA ≤ I _{OUT} ≤ I _{MAX} (Note 4)		0.1	0.3	%	
			0.3	1	%	
Thermal Regulation	20 ms Pulse		0.03	0.07	%/W	
Adjustment Pin Current			50	100	μA	
Adjustment Pin Current Change	10 mA ≤ I _{OUT} ≤ I _{MAX} 3V ≤ (V _{IN} - V _{OUT}) ≤ 40V		0.2	5	μA	
Temperature Stability	T _{MIN} ≤ T _J ≤ T _{MAX}		1		%	
Minimum Load Current	(V _{IN} - V _{OUT}) = 40V		3.5	5	mA	
Current Limit	(V _{IN} - V _{OUT}) ≤ 15V	K Package	1.5	2.2	3.4	A
		H Packages	0.5	0.8	1.8	A
	(V _{IN} - V _{OUT}) = 40V	K Package	0.3	0.4		A
		H Package	0.15	0.2		A
RMS Output Noise, % of V _{OUT}	10 Hz ≤ f ≤ 10 kHz		0.003		%	
Ripple Rejection Ratio	V _{OUT} = 10V, f = 120 Hz, C _{ADJ} = 0 μF		65		dB	
	V _{OUT} = 10V, f = 120 Hz, C _{ADJ} = 10 μF	66	80		dB	
Long-Term Stability	T _J = 125°C, 1000 hrs		0.3	1	%	
Thermal Resistance, Junction-to-Case	K Package		2.3	3	°C/W	
	H Package		12	15	°C/W	
	E Package				°C/W	
Thermal Resistance, Junction-to-Ambient (No Heat Sink)	K Package		35		°C/W	
	H Package		140		°C/W	
	E Package				°C/W	

Electrical Characteristics (Note 3)

Specifications with standard type face are for $T_J = 25^\circ\text{C}$, and those with **boldface type** apply over **full Operating Temperature Range**. Unless otherwise specified, $V_{IN} - V_{OUT} = 5\text{V}$, and $I_{OUT} = 10\text{ mA}$.

Parameter	Conditions	LM317A			LM317			Units	
		Min	Typ	Max	Min	Typ	Max		
Reference Voltage		1.238	1.250	1.262				V	
	$3\text{V} \leq (V_{IN} - V_{OUT}) \leq 40\text{V}$, $10\text{ mA} \leq I_{OUT} \leq I_{MAX}$, $P \leq P_{MAX}$	1.225	1.250	1.270	1.20	1.25	1.30	V	
Line Regulation	$3\text{V} \leq (V_{IN} - V_{OUT}) \leq 40\text{V}$ (Note 4)		0.005	0.01		0.01	0.04	%/V	
			0.01	0.02		0.02	0.07	%/V	
Load Regulation	$10\text{ mA} \leq I_{OUT} \leq I_{MAX}$ (Note 4)		0.1	0.5		0.1	0.5	%	
			0.3	1		0.3	1.5	%	
Thermal Regulation	20 ms Pulse		0.04	0.07		0.04	0.07	%/W	
Adjustment Pin Current			50	100		50	100	μA	
Adjustment Pin Current Change	$10\text{ mA} \leq I_{OUT} \leq I_{MAX}$ $3\text{V} \leq (V_{IN} - V_{OUT}) \leq 40\text{V}$		0.2	5		0.2	5	μA	
Temperature Stability	$T_{MIN} \leq T_J \leq T_{MAX}$		1			1		%	
Minimum Load Current	$(V_{IN} - V_{OUT}) = 40\text{V}$		3.5	10		3.5	10	mA	
Current Limit	$(V_{IN} - V_{OUT}) \leq 15\text{V}$ K, T, S Packages H Package MP Package		1.5	2.2	3.4	1.5	2.2	3.4	A
			0.5	0.8	1.8	0.5	0.8	1.8	A
			1.5	2.2	3.4	1.5	2.2	3.4	A
	$(V_{IN} - V_{OUT}) = 40\text{V}$ K, T, S Packages H Package MP Package		0.15	0.4		0.15	0.4		A
			0.075	0.2		0.075	0.2		A
			0.55	0.4		0.15	0.4		A
RMS Output Noise, % of V_{OUT}	$10\text{ Hz} \leq f \leq 10\text{ kHz}$		0.003			0.003		%	
Ripple Rejection Ratio	$V_{OUT} = 10\text{V}$, $f = 120\text{ Hz}$, $C_{ADJ} = 0\text{ }\mu\text{F}$		65			65		dB	
	$V_{OUT} = 10\text{V}$, $f = 120\text{ Hz}$, $C_{ADJ} = 10\text{ }\mu\text{F}$	66	80		66	80		dB	
Long-Term Stability	$T_J = 125^\circ\text{C}$, 1000 hrs		0.3	1		0.3	1	%	
Thermal Resistance, Junction-to-Case	K Package					2.3	3	$^\circ\text{C/W}$	
	MDT Package					5		$^\circ\text{C/W}$	
	H Package		12	15		12	15	$^\circ\text{C/W}$	
	T Package		4	5		4		$^\circ\text{C/W}$	
	MP Package		23.5			23.5		$^\circ\text{C/W}$	
Thermal Resistance, Junction-to-Ambient (No Heat Sink)	K Package		35			35		$^\circ\text{C/W}$	
	MDT Package (Note 6)					92		$^\circ\text{C/W}$	
	H Package		140			140		$^\circ\text{C/W}$	
	T Package		50			50		$^\circ\text{C/W}$	
	S Package (Note 6)		50			50		$^\circ\text{C/W}$	

Note 1: Absolute Maximum Ratings indicate limits beyond which damage to the device may occur. Operating Ratings indicate conditions for which the device is intended to be functional, but do not guarantee specific performance limits. For guaranteed specifications and test conditions, see the Electrical Characteristics. The guaranteed specifications apply only for the test conditions listed.

Note 2: Refer to RETS117H drawing for the LM117H, or the RETS117K for the LM117K military specifications.

Note 3: Although power dissipation is internally limited, these specifications are applicable for maximum power dissipations of 2W for the TO-39 and SOT-223 and 20W for the TO-3, TO-220, and TO-263. I_{MAX} is 1.5A for the TO-3, TO-220, and TO-263 packages, 0.5A for the TO-39 package and 1A for the SOT-223 Package. All limits (i.e., the numbers in the Min. and Max. columns) are guaranteed to National's AOQL (Average Outgoing Quality Level).

Note 4: Regulation is measured at a constant junction temperature, using pulse testing with a low duty cycle. Changes in output voltage due to heating effects are covered under the specifications for thermal regulation.

Note 5: Human body model, 100 pF discharged through a 1.5 k Ω resistor.

Note 6: If the TO-263 or TO-252 packages are used, the thermal resistance can be reduced by increasing the PC board copper area thermally connected to the package. If the SOT-223 package is used, the thermal resistance can be reduced by increasing the PC board copper area (see applications hints for heatsinking).

Typical Performance Characteristics

Output Capacitor = 0 μ F unless otherwise noted

Load Regulation

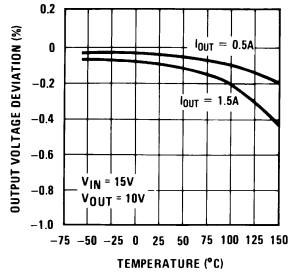

Current Limit

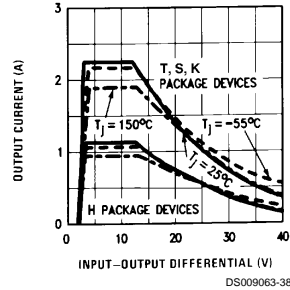

Adjustment Current

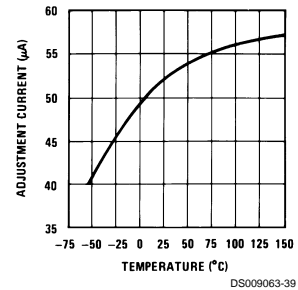

Dropout Voltage

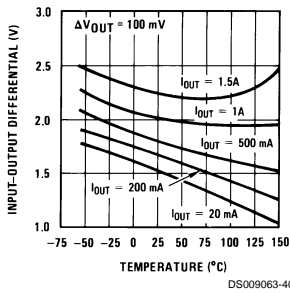

Temperature Stability

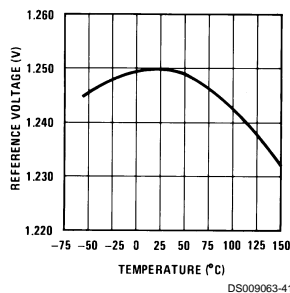

Minimum Operating Current

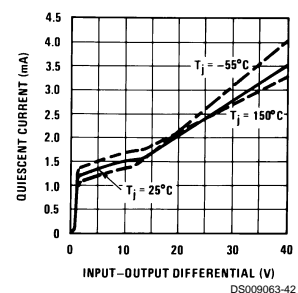

Ripple Rejection

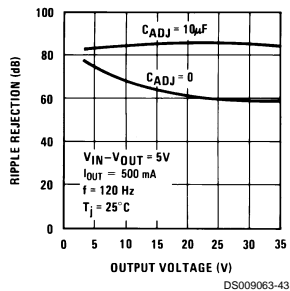

Ripple Rejection

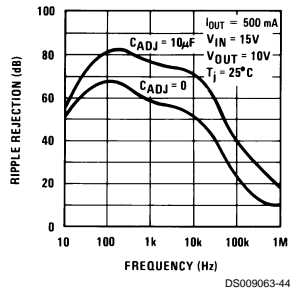

Ripple Rejection

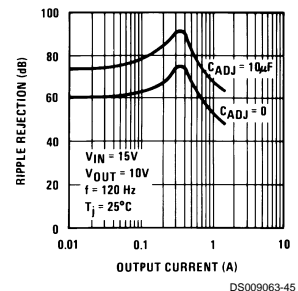

Output Impedance

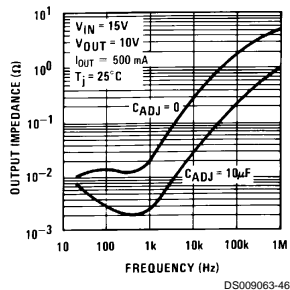

Line Transient Response

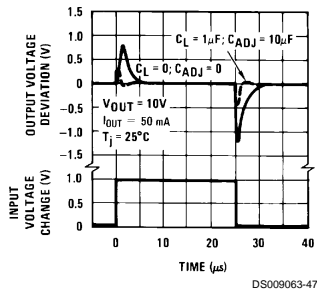

Load Transient Response

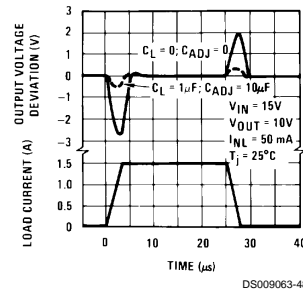

Application Hints

In operation, the LM117 develops a nominal 1.25V reference voltage, V_{REF} , between the output and adjustment terminal. The reference voltage is impressed across program resistor R1 and, since the voltage is constant, a constant current I_1 then flows through the output set resistor R2, giving an output voltage of

$$V_{OUT} = V_{REF} \left(1 + \frac{R2}{R1} \right) + I_{ADJ}R2$$

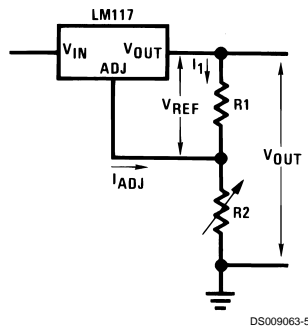

FIGURE 1.

Since the 100 μ A current from the adjustment terminal represents an error term, the LM117 was designed to minimize I_{ADJ} and make it very constant with line and load changes. To do this, all quiescent operating current is returned to the output establishing a minimum load current requirement. If there is insufficient load on the output, the output will rise.

External Capacitors

An input bypass capacitor is recommended. A 0.1 μ F disc or 1 μ F solid tantalum on the input is suitable input bypassing for almost all applications. The device is more sensitive to the absence of input bypassing when adjustment or output capacitors are used but the above values will eliminate the possibility of problems.

The adjustment terminal can be bypassed to ground on the LM117 to improve ripple rejection. This bypass capacitor prevents ripple from being amplified as the output voltage is increased. With a 10 μ F bypass capacitor 80 dB ripple rejection is obtainable at any output level. Increases over 10 μ F do not appreciably improve the ripple rejection at frequencies above 120 Hz. If the bypass capacitor is used, it is sometimes necessary to include protection diodes to prevent the capacitor from discharging through internal low current paths and damaging the device.

In general, the best type of capacitors to use is solid tantalum. Solid tantalum capacitors have low impedance even at high frequencies. Depending upon capacitor construction, it takes about 25 μ F in aluminum electrolytic to equal 1 μ F solid tantalum at high frequencies. Ceramic capacitors are also good at high frequencies; but some types have a large decrease in capacitance at frequencies around 0.5 MHz. For this reason, 0.01 μ F disc may seem to work better than a 0.1 μ F disc as a bypass.

Although the LM117 is stable with no output capacitors, like any feedback circuit, certain values of external capacitance can cause excessive ringing. This occurs with values between 500 pF and 5000 pF. A 1 μ F solid tantalum (or 25 μ F

aluminum electrolytic) on the output swamps this effect and insures stability. Any increase of the load capacitance larger than 10 μ F will merely improve the loop stability and output impedance.

Load Regulation

The LM117 is capable of providing extremely good load regulation but a few precautions are needed to obtain maximum performance. The current set resistor connected between the adjustment terminal and the output terminal (usually 240 Ω) should be tied directly to the output (case) of the regulator rather than near the load. This eliminates line drops from appearing effectively in series with the reference and degrading regulation. For example, a 15V regulator with 0.05 Ω resistance between the regulator and load will have a load regulation due to line resistance of 0.05 Ω \times I_L . If the set resistor is connected near the load the effective line resistance will be 0.05 Ω (1 + R2/R1) or in this case, 11.5 times worse.

Figure 2 shows the effect of resistance between the regulator and 240 Ω set resistor.

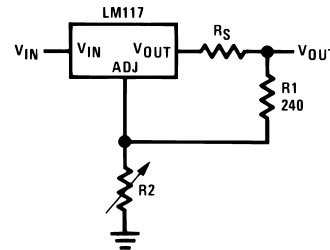

FIGURE 2. Regulator with Line Resistance in Output Lead

With the TO-3 package, it is easy to minimize the resistance from the case to the set resistor, by using two separate leads to the case. However, with the TO-39 package, care should be taken to minimize the wire length of the output lead. The ground of R2 can be returned near the ground of the load to provide remote ground sensing and improve load regulation.

Protection Diodes

When external capacitors are used with any IC regulator it is sometimes necessary to add protection diodes to prevent the capacitors from discharging through low current points into the regulator. Most 10 μ F capacitors have low enough internal series resistance to deliver 20A spikes when shorted. Although the surge is short, there is enough energy to damage parts of the IC.

When an output capacitor is connected to a regulator and the input is shorted, the output capacitor will discharge into the output of the regulator. The discharge current depends on the value of the capacitor, the output voltage of the regulator, and the rate of decrease of V_{IN} . In the LM117, this discharge path is through a large junction that is able to sustain 15A surge with no problem. This is not true of other types of positive regulators. For output capacitors of 25 μ F or less, there is no need to use diodes.

The bypass capacitor on the adjustment terminal can discharge through a low current junction. Discharge occurs when either the input or output is shorted. Internal to the LM117 is a 50 Ω resistor which limits the peak discharge current. No protection is needed for output voltages of 25V or

Application Hints (Continued)

less and 10 μF capacitance. *Figure 3* shows an LM117 with protection diodes included for use with outputs greater than 25V and high values of output capacitance.

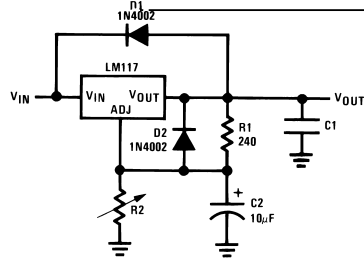

DS009063-7

$$V_{OUT} = 1.25V \left(1 + \frac{R_2}{R_1} \right) + I_{ADJ}R_2$$

D1 protects against C1
D2 protects against C2

FIGURE 3. Regulator with Protection Diodes

When a value for $\theta_{(H-A)}$ is found using the equation shown, a heatsink must be selected that has a value that is less than or equal to this number.

$\theta_{(H-A)}$ is specified numerically by the heatsink manufacturer in the catalog, or shown in a curve that plots temperature rise vs power dissipation for the heatsink.

HEATSINKING TO-263, SOT-223 AND TO-252 PACKAGE PARTS

The TO-263 ("S"), SOT-223 ("MP") and TO-252 ("DT") packages use a copper plane on the PCB and the PCB itself as a heatsink. To optimize the heat sinking ability of the plane and PCB, solder the tab of the package to the plane.

Figure 4 shows for the TO-263 the measured values of $\theta_{(J-A)}$ for different copper area sizes using a typical PCB with 1 ounce copper and no solder mask over the copper area used for heatsinking.

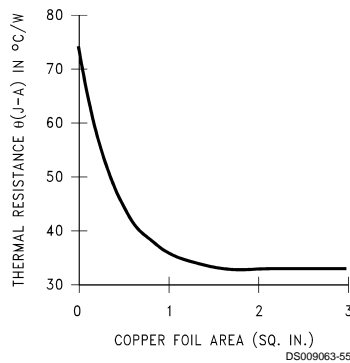

DS009063-55

FIGURE 4. $\theta_{(J-A)}$ vs Copper (1 ounce) Area for the TO-263 Package

As shown in the figure, increasing the copper area beyond 1 square inch produces very little improvement. It should also be observed that the minimum value of $\theta_{(J-A)}$ for the TO-263 package mounted to a PCB is 32°C/W.

As a design aid, *Figure 5* shows the maximum allowable power dissipation compared to ambient temperature for the TO-263 device (assuming $\theta_{(J-A)}$ is 35°C/W and the maximum junction temperature is 125°C).

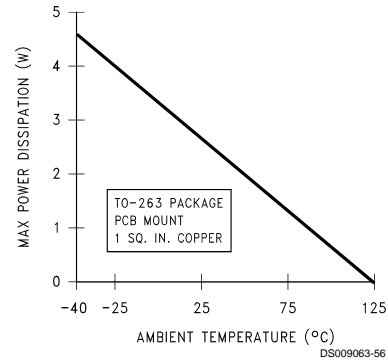

DS009063-56

FIGURE 5. Maximum Power Dissipation vs T_{AMB} for the TO-263 Package

Figure 6 and *Figure 7* show the information for the SOT-223 package. *Figure 7* assumes a $\theta_{(J-A)}$ of 74°C/W for 1 ounce copper and 51°C/W for 2 ounce copper and a maximum junction temperature of 125°C.

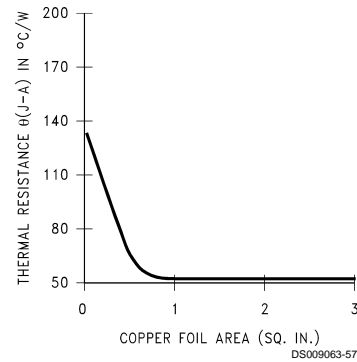

DS009063-57

FIGURE 6. $\theta_{(J-A)}$ vs Copper (2 ounce) Area for the SOT-223 Package

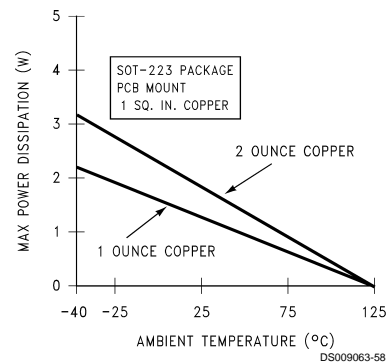

DS009063-58

FIGURE 7. Maximum Power Dissipation vs T_{AMB} for the SOT-223 Package

Application Hints (Continued)

The LM317 regulators have internal thermal shutdown to protect the device from over-heating. Under all possible operating conditions, the junction temperature of the LM317 must be within the range of 0°C to 125°C. A heatsink may be required depending on the maximum power dissipation and maximum ambient temperature of the application. To determine if a heatsink is needed, the power dissipated by the regulator, P_D , must be calculated:

$$I_{IN} = I_L + I_G$$

$$P_D = (V_{IN} - V_{OUT}) I_L + V_{IN} I_G$$

Figure 8 shows the voltage and currents which are present in the circuit.

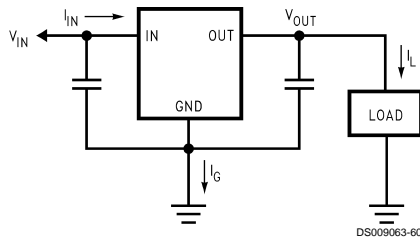

FIGURE 8. Power Dissipation Diagram

The next parameter which must be calculated is the maximum allowable temperature rise, $T_R(\max)$:

$$T_R(\max) = T_J(\max) - T_A(\max)$$

where $T_J(\max)$ is the maximum allowable junction temperature (125°C), and $T_A(\max)$ is the maximum ambient temperature which will be encountered in the application.

Using the calculated values for $T_R(\max)$ and P_D , the maximum allowable value for the junction-to-ambient thermal resistance (θ_{JA}) can be calculated:

$$\theta_{JA} = T_R(\max)/P_D$$

If the maximum allowable value for θ_{JA} is found to be $\geq 92^\circ\text{C/W}$ (Typical Rated Value) for TO-252 package, no heatsink is needed since the package alone will dissipate enough heat to satisfy these requirements. If the calculated value for θ_{JA} falls below these limits, a heatsink is required.

As a design aid, Table 1 shows the value of the θ_{JA} of TO-252 for different heatsink area. The copper patterns that we used to measure these θ_{JA} s are shown at the end of the Application Notes Section. Figure 9 reflects the same test results as what are in the Table 1

Figure 10 shows the maximum allowable power dissipation vs. ambient temperature for the TO-252 device. Figure 11 shows the maximum allowable power dissipation vs. copper area (in^2) for the TO-252 device. Please see AN1028 for power enhancement techniques to be used with SOT-223 and TO-252 packages.

TABLE 1. θ_{JA} Different Heatsink Area

Layout	Copper Area		Thermal Resistance ($\theta_{JA}^\circ\text{C/W}$) TO-252
	Top Side (in^2)*	Bottom Side (in^2)	
1	0.0123	0	103
2	0.066	0	87
3	0.3	0	60
4	0.53	0	54
5	0.76	0	52
6	1	0	47
7	0	0.2	84
8	0	0.4	70
9	0	0.6	63
10	0	0.8	57
11	0	1	57
12	0.066	0.066	89
13	0.175	0.175	72
14	0.284	0.284	61
15	0.392	0.392	55
16	0.5	0.5	53

Note: * Tab of device attached to top side of copper.

Application Hints (Continued)

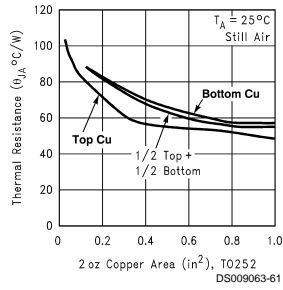

FIGURE 9. θ_{JA} vs 2oz Copper Area for TO-252

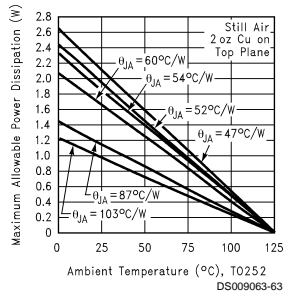

FIGURE 10. Maximum Allowable Power Dissipation vs. Ambient Temperature for TO-252

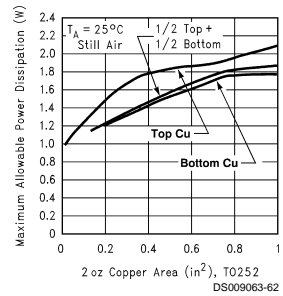

FIGURE 11. Maximum Allowable Power Dissipation vs. 2oz Copper Area for TO-252

Application Hints (Continued)

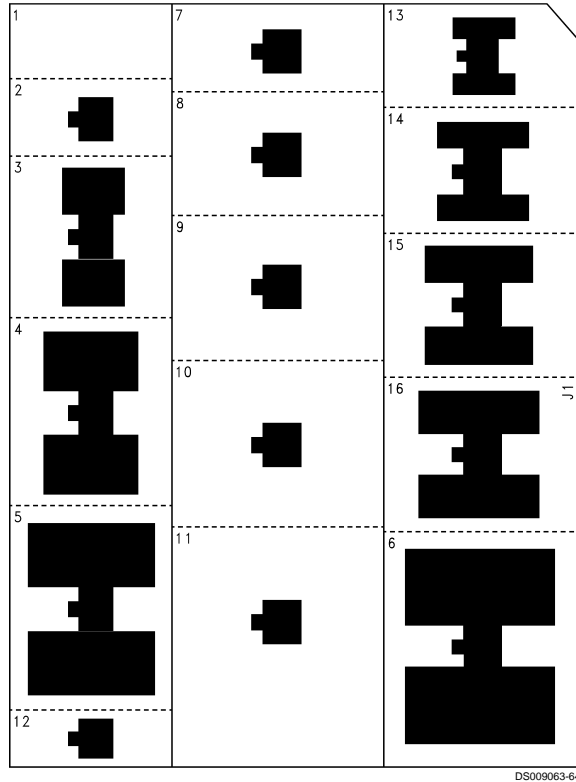
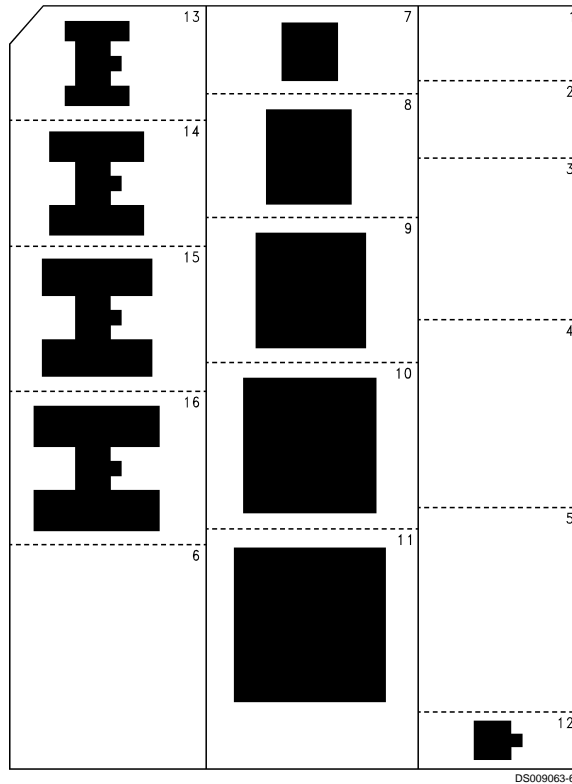

FIGURE 12. Top View of the Thermal Test Pattern in Actual Scale

Application Hints (Continued)



DS009063-65

FIGURE 13. Bottom View of the Thermal Test Pattern in Actual Scale

Schematic Diagram

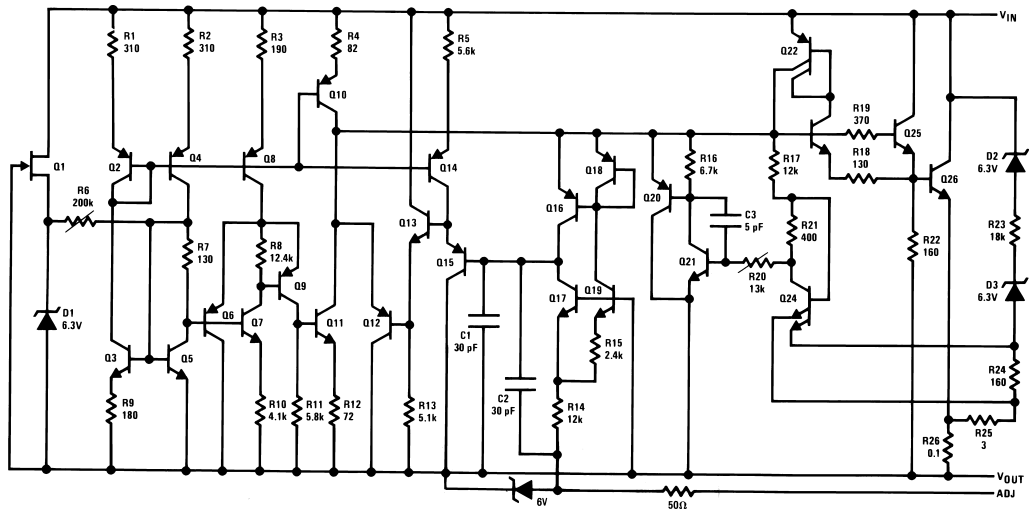

Typical Applications

5V Logic Regulator with Electronic Shutdown*

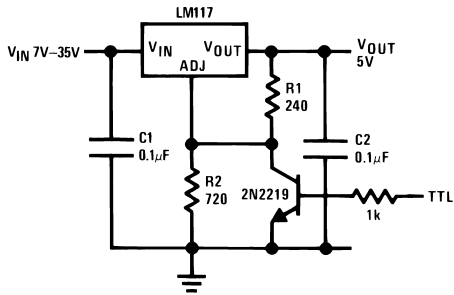

*Min. output \approx 1.2V

Slow Turn-On 15V Regulator

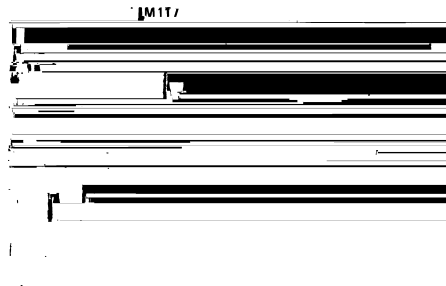

Typical Applications (Continued)

Adjustable Regulator with Improved Ripple Rejection

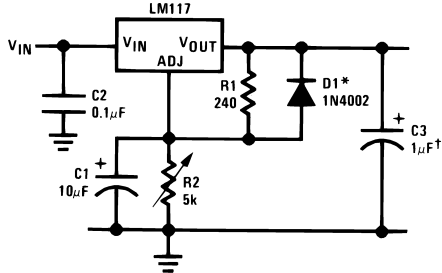

DS009063-10

†Solid tantalum

*Discharges C1 if output is shorted to ground

High Stability 10V Regulator

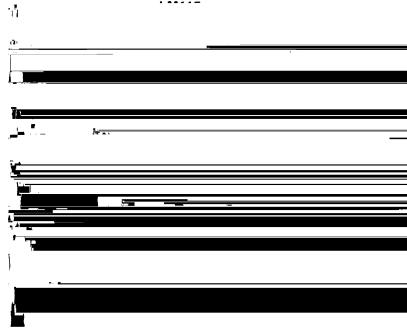

DS009063-11

High Current Adjustable Regulator

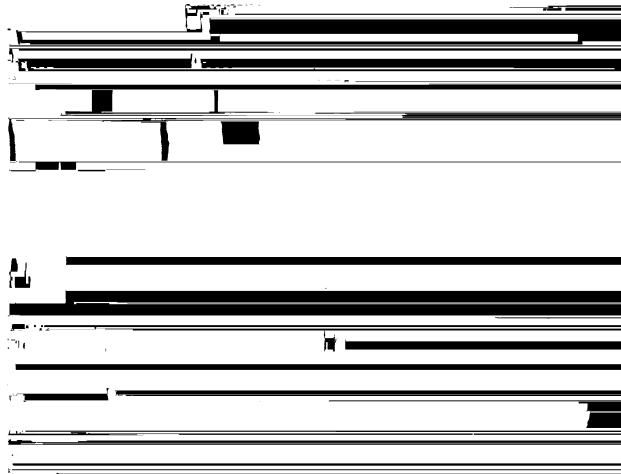

DS009063-12

‡Optional — improves ripple rejection

†Solid tantalum

*Minimum load current = 30 mA

Typical Applications (Continued)

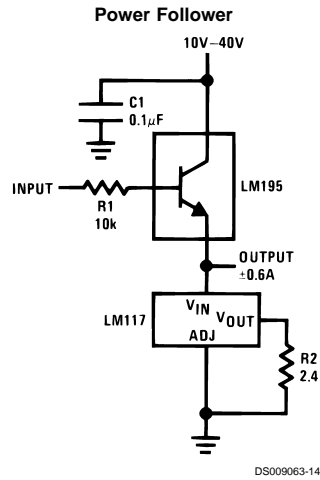
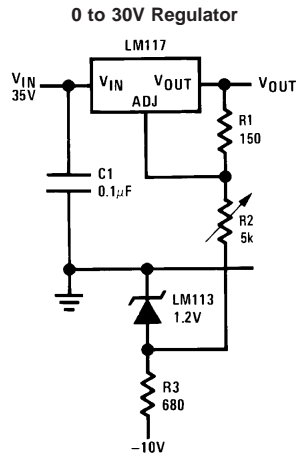

Full output current not available at high input-output voltages

5A Constant Voltage/Constant Current Regulator

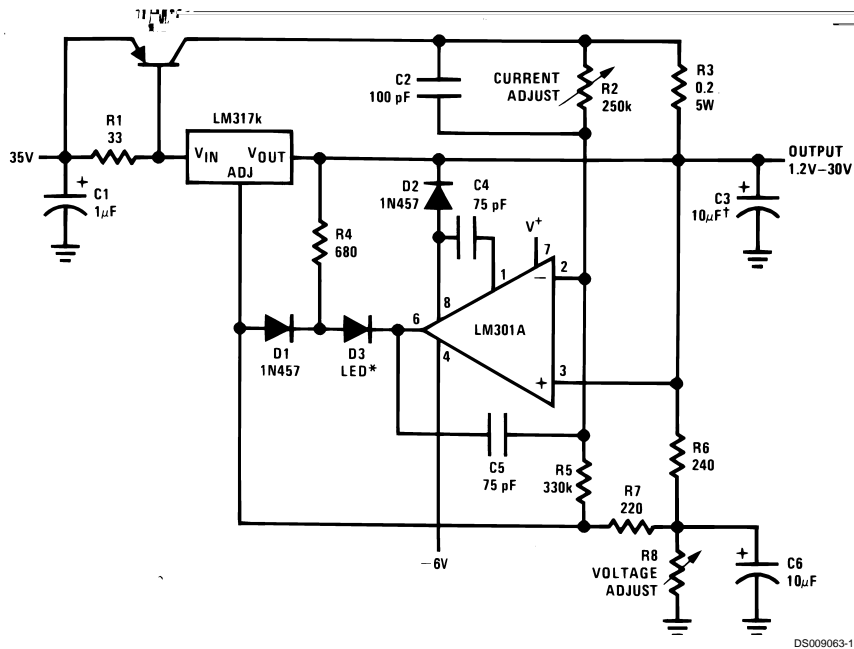

†Solid tantalum
*Lights in constant current mode

Typical Applications (Continued)

1A Current Regulator

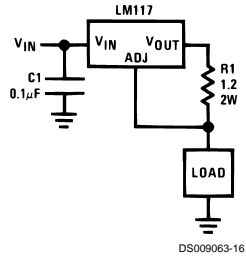

DS009063-16

1.2V–20V Regulator with Minimum Program Current

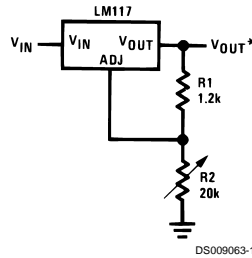

DS009063-17

*Minimum load current = 4 mA

High Gain Amplifier

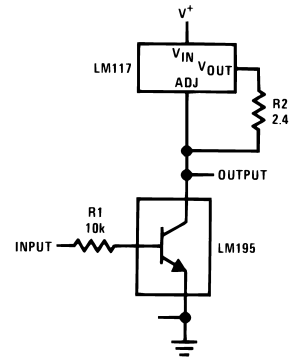

DS009063-18

Low Cost 3A Switching Regulator

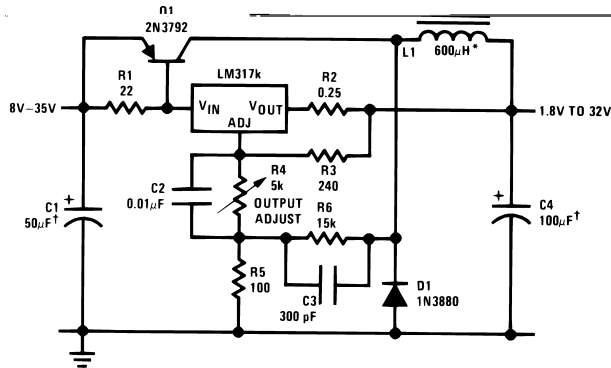

DS009063-19

†Solid tantalum

*Core—Arnold A-254168-2 60 turns

Typical Applications (Continued)

4A Switching Regulator with Overload Protection

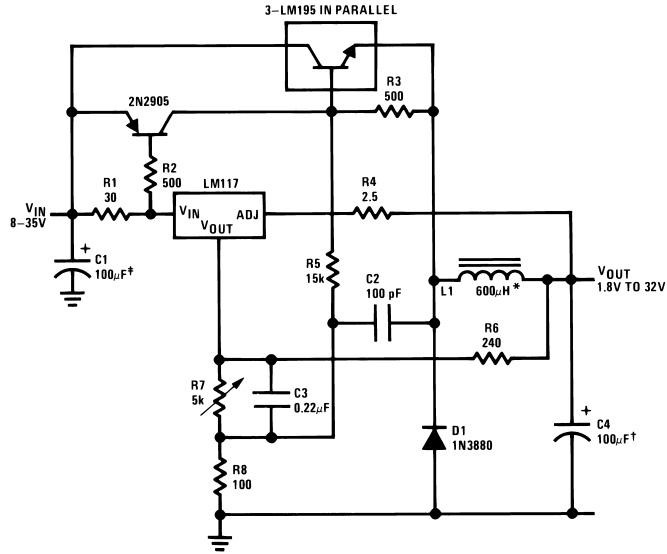

DS009063-20

†Solid tantalum

*Core — Arnold A-254168-2 60 turns

Precision Current Limiter

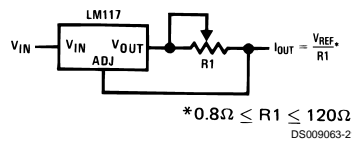

DS009063-21

Tracking Preregulator

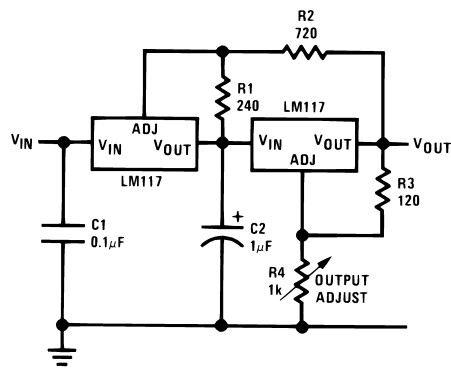

DS009063-22

Typical Applications (Continued)

Current Limited Voltage Regulator

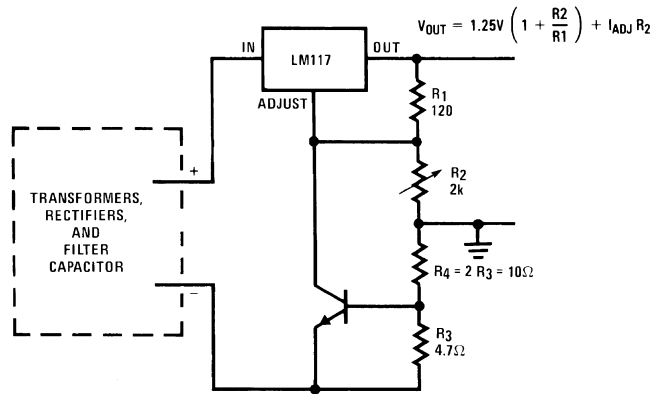

DS009063-23

— Short circuit current is approximately $\frac{600 \text{ mV}}{R_3}$, or 120 mA

(Compared to LM117's higher current limit)

— At 50 mA output only $\frac{1}{4}$ volt of drop occurs in R_3 and R_4

Adjusting Multiple On-Card Regulators with Single Control*

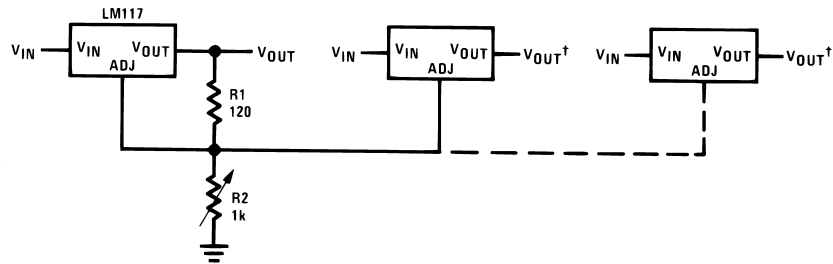

DS009063-24

*All outputs within $\pm 100 \text{ mV}$

†Minimum load — 10 mA

AC Voltage Regulator

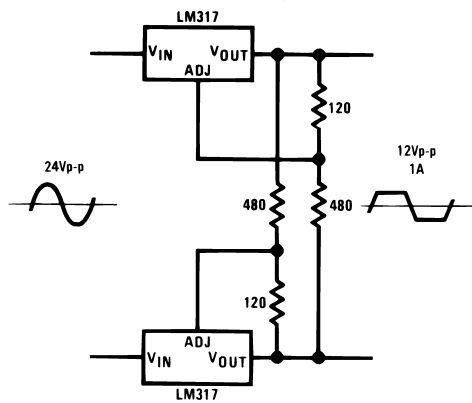

DS009063-25

Typical Applications (Continued)

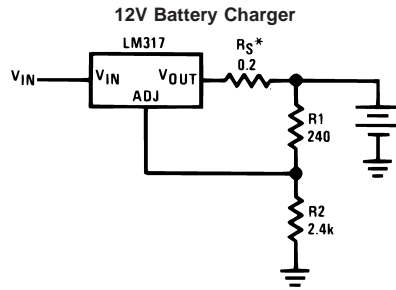

DS009063-26

* R_S —sets output impedance of charger: $Z_{OUT} = R_S \left(1 + \frac{R_2}{R_1} \right)$

Use of R_S allows low charging rates with fully charged battery.

50 mA Constant Current Battery Charger

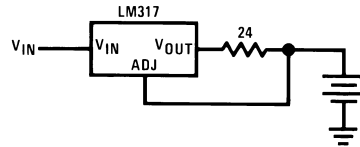

DS009063-27

Adjustable 4A Regulator

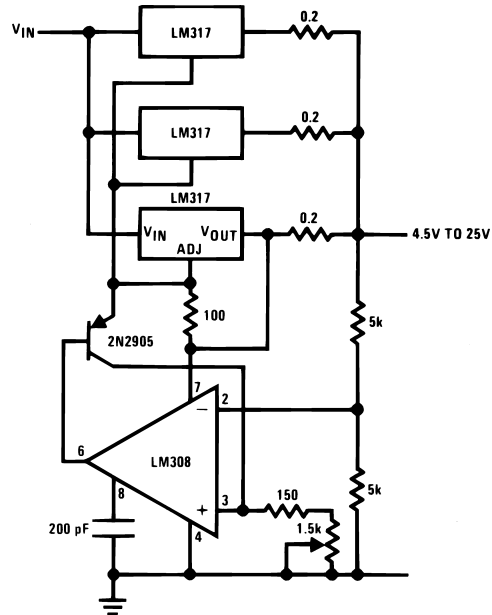

DS009063-28

Typical Applications (Continued)

Current Limited 6V Charger

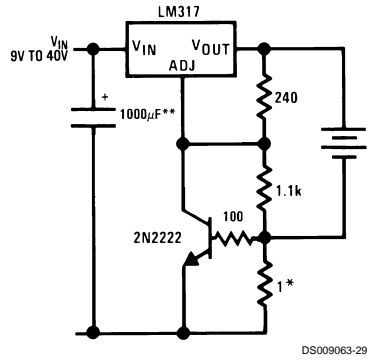

*Sets peak current (0.6A for 1Ω)

**The 1000 µF is recommended to filter out input transients

Digitally Selected Outputs

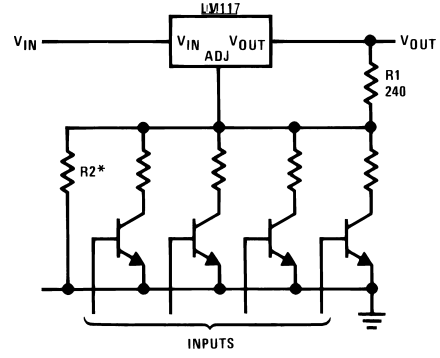

*Sets maximum V_{OUT}

Connection Diagrams

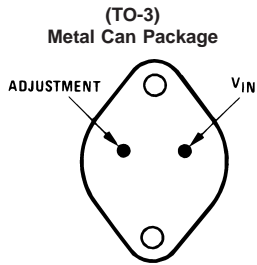

DS009063-30
 CASE IS OUTPUT
Bottom View
Steel Package
 Order Number LM117K STEEL
 or LM317K STEEL
 See NS Package Number K02A
 Order Number LM117K/883
 See NS Package Number K02C

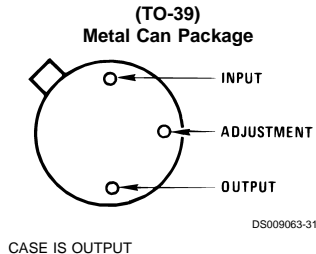

DS009063-31
 CASE IS OUTPUT
Bottom View
 Order Number LM117H,
 LM117H/883,
 LM317AH or LM317H
 See NS Package Number H03A

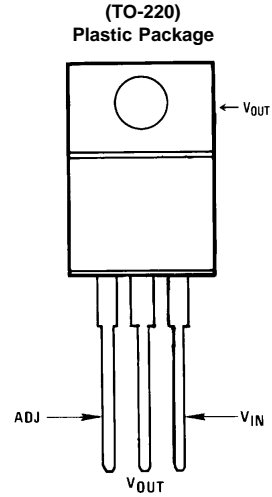

DS009063-32
Front View
 Order Number LM317AT or LM317T
 See NS Package Number T03B

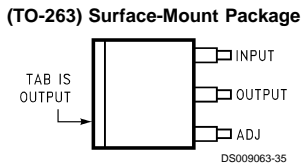

DS009063-35
Top View



DS009063-36
Side View
 Order Number LM317S
 See NS Package Number TS3B

**Ceramic Leadless
 Chip Carrier**

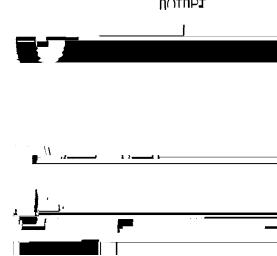

DS009063-34
Top View
 Order Number LM117E/883
 See NS Package Number E20A

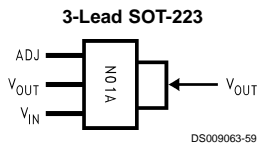

DS009063-59
Front View
 Order Part Number LM317EMP or
 LM317AEMP
 Package Marked N01A
 See NSC Package Number MA04A

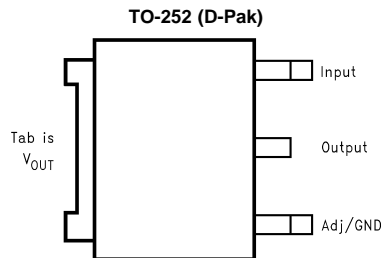

DS009063-66
Front View
 Order Part Number LM317DT
 See NSC Package Number TD03B

Physical Dimensions inches (millimeters) unless otherwise noted

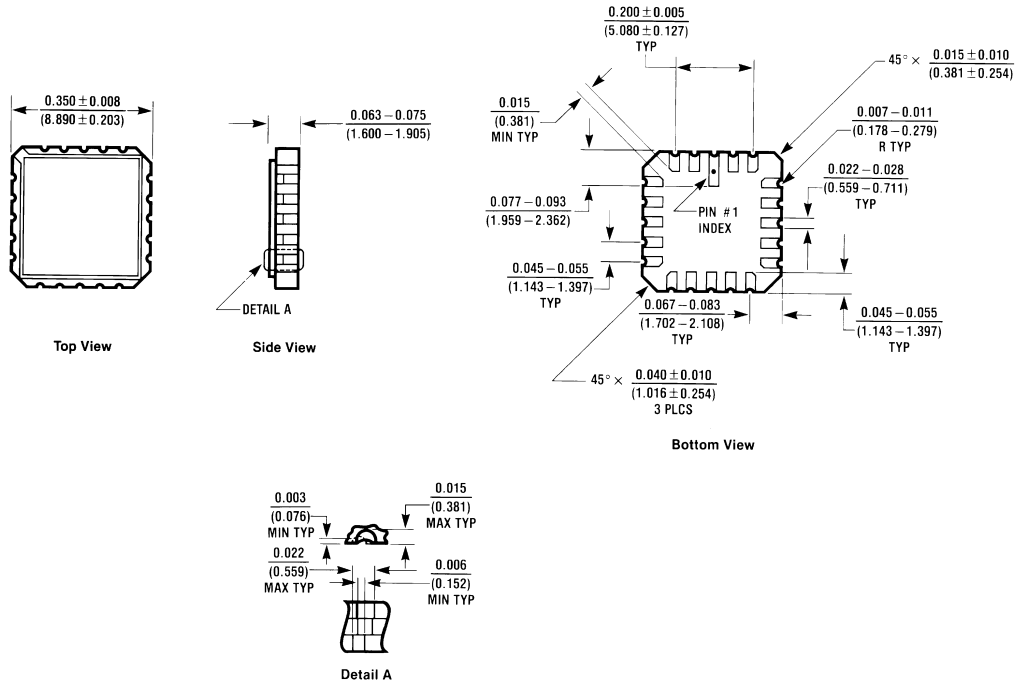

E20A (REV D)

Ceramic Leadless Chip Carrier
Order Number LM117E/883
NS Package Number E20A

Physical Dimensions inches (millimeters) unless otherwise noted (Continued)

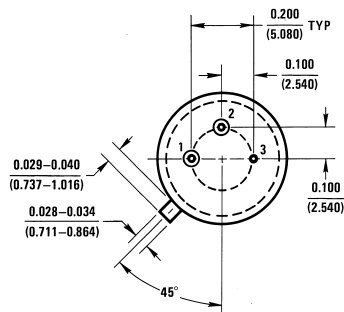
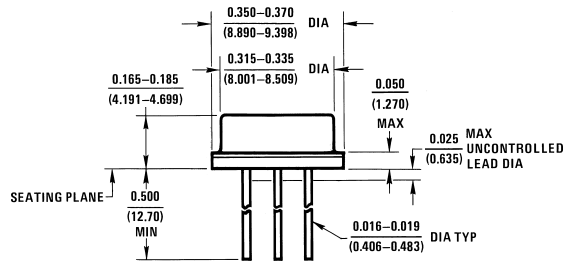

H03A (REV B)

(TO-39) Metal Can Package
Order Number LM117H, LM117H/883, LM317AH or LM317H
NS Package Number H03A

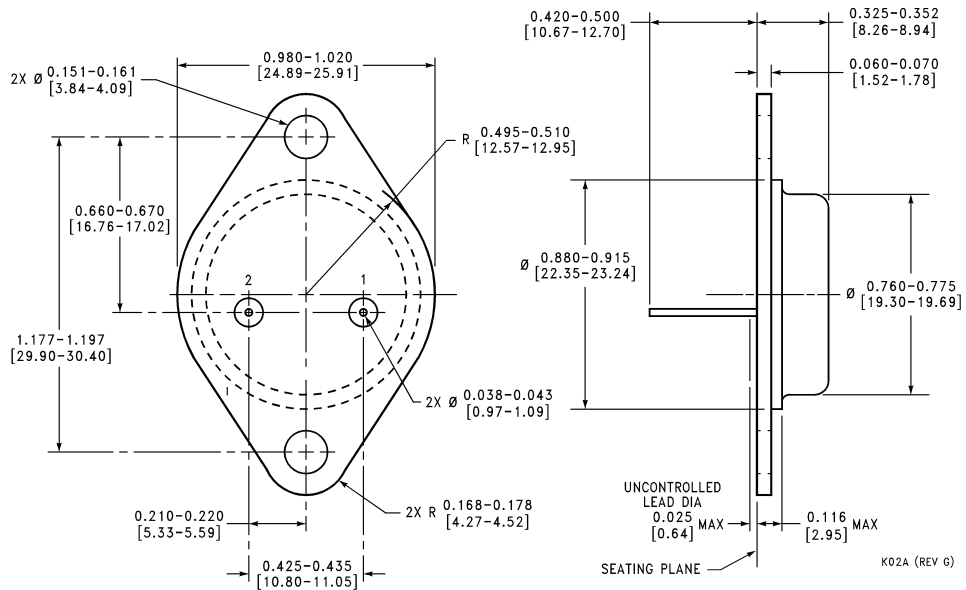

K02A (REV G)

TO-3 Metal Can Package (K)
Order Number LM117K STEEL,
LM117K STEEL/883, or LM317K STEEL
NS Package Number K02A

Physical Dimensions inches (millimeters) unless otherwise noted (Continued)

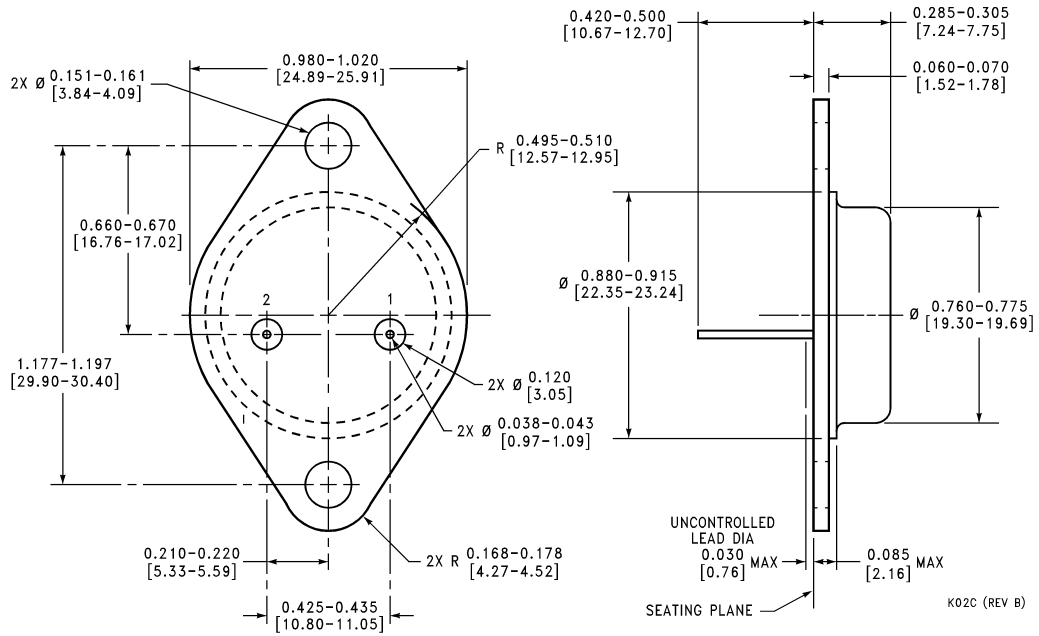

TO-3 Metal Can Package (K)
Mil-Aero Product
Order Number LM117K/883
NS Package Number K02C

Physical Dimensions inches (millimeters) unless otherwise noted (Continued)

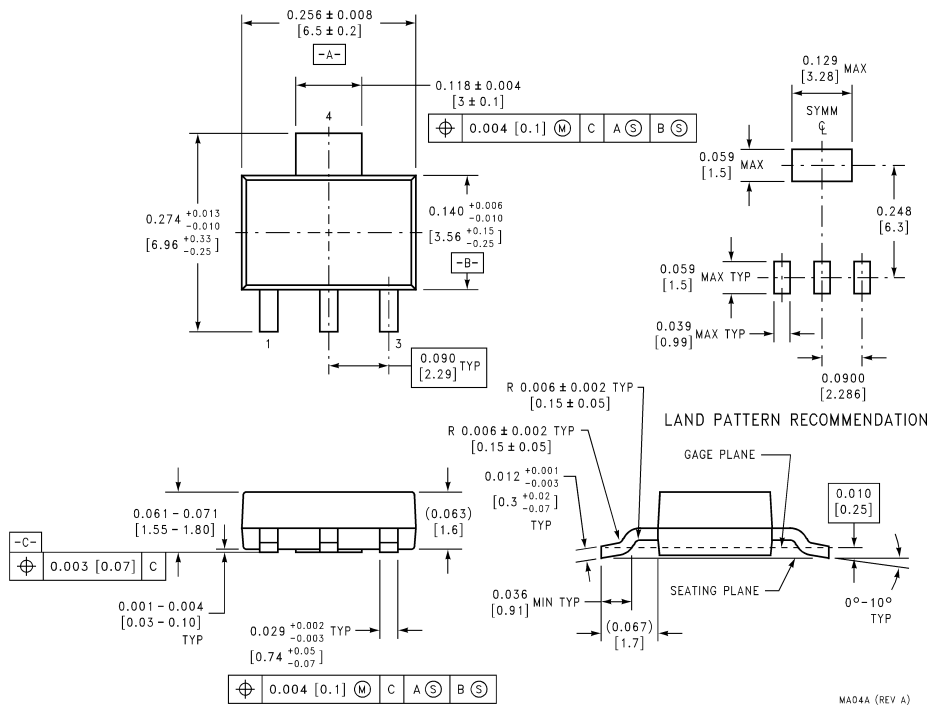

3-Lead SOT-223 Package
Order Number LM317AEMP or LM317EMP
NS Package Number MA04A

MA04A (REV A)

Physical Dimensions inches (millimeters) unless otherwise noted (Continued)

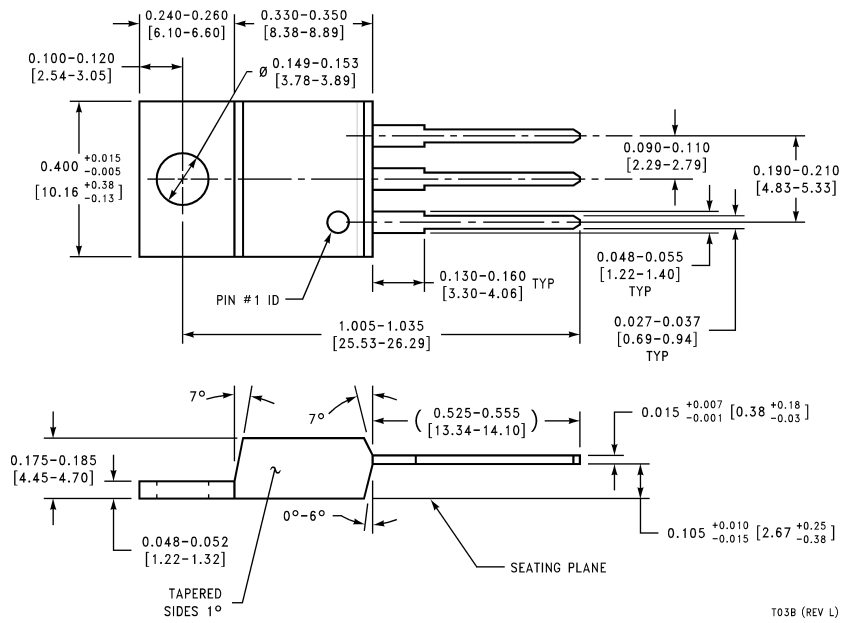

T03B (REV L)

(TO-220) Outline Drawing
Order Number LM317AT or LM317T
NS Package Number T03B

Physical Dimensions inches (millimeters) unless otherwise noted (Continued)

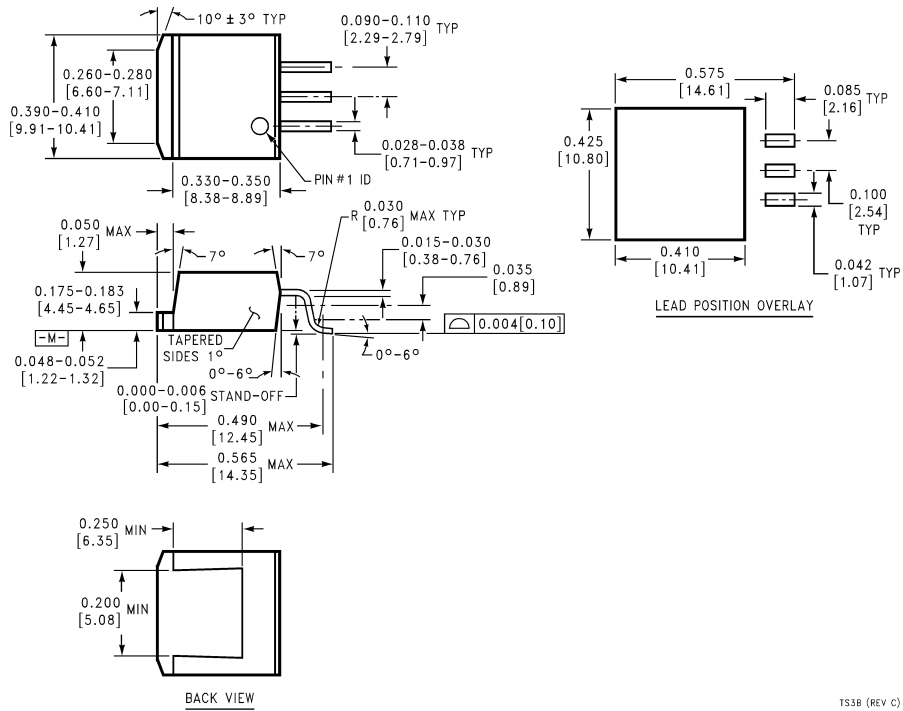

Order Number LM317S
NS Package Number TS3B

TS3B (REV C)

Physical Dimensions inches (millimeters) unless otherwise noted (Continued)

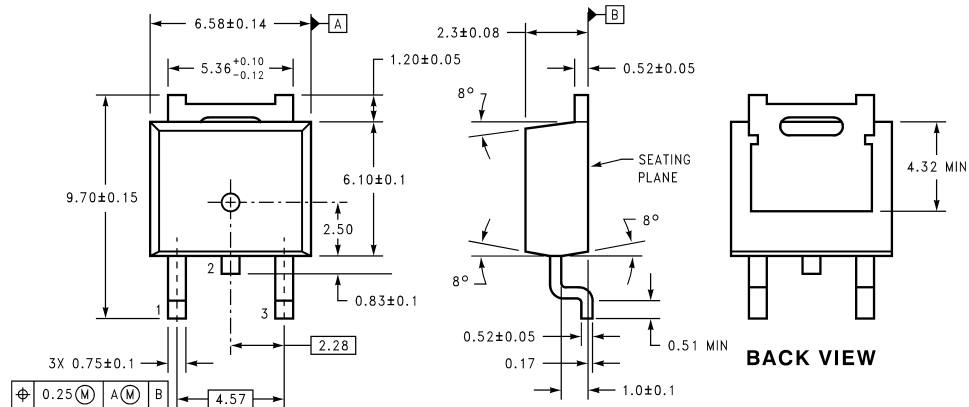

DIMENSIONS ARE IN MILLIMETERS

TD03B (REV A)

Order Number LM317MDT
 NS Package Number TD03B

LIFE SUPPORT POLICY

NATIONAL'S PRODUCTS ARE NOT AUTHORIZED FOR USE AS CRITICAL COMPONENTS IN LIFE SUPPORT DEVICES OR SYSTEMS WITHOUT THE EXPRESS WRITTEN APPROVAL OF THE PRESIDENT AND GENERAL COUNSEL OF NATIONAL SEMICONDUCTOR CORPORATION. As used herein:

1. Life support devices or systems are devices or systems which, (a) are intended for surgical implant into the body, or (b) support or sustain life, and whose failure to perform when properly used in accordance with instructions for use provided in the labeling, can be reasonably expected to result in a significant injury to the user.
2. A critical component is any component of a life support device or system whose failure to perform can be reasonably expected to cause the failure of the life support device or system, or to affect its safety or effectiveness.



National Semiconductor Corporation
 Americas
 Tel: 1-800-272-9959
 Fax: 1-800-737-7018
 Email: support@nsc.com

National Semiconductor Europe
 Fax: +49 (0) 1 80-530 85 86
 Email: europe.support@nsc.com
 Deutsch Tel: +49 (0) 1 80-530 85 85
 English Tel: +49 (0) 1 80-532 78 32
 Français Tel: +49 (0) 1 80-532 93 58
 Italiano Tel: +49 (0) 1 80-534 16 80

National Semiconductor Asia Pacific Customer Response Group
 Tel: 65-2544466
 Fax: 65-2504466
 Email: sea.support@nsc.com

National Semiconductor Japan Ltd.
 Tel: 81-3-5639-7560
 Fax: 81-3-5639-7507

www.national.com