

# VIDEO CABLING ALTERNATIVES TO COAX IN PREMISE WIRING ENVIRONMENTS

*For baseband or broadband video wiring, coaxial cable is no longer the only game in town for "the last 100 meters".*

**BY ED KOPAKOWSKI  
FORCE, INCORPORATED**

Since the early 1960's, the standard commercial video wiring medium has been 75-Ohm baseband and broadband coaxial cable (as opposed to 50-Ohm datacom coaxial cable). Today, however, coax is no longer the only game in town for "the last 100 meters" in nonresidential environments.

Installers now have three cost-effective and often superior baseband and broadband video cabling alternatives: (1) optical fiber (multimode and single-mode); (2) UTP (Category 3 and Category 5), and; (3) HFC (or Hybrid Fiber Copper) combinations of fiber and UTP. These topologies for building baseband CCTV or broadband MATV video networks are commercially available from several major manufacturers, are architecturally similar to those available for data and voice networks, and deliver exceptional cost/performance value in a growing number of application scenarios.

## **Video Transmission in LAN Environments**

Structured premise wiring systems from major vendors (i.e. AMP Centralized Network Administration, AT&T SYSTIMAX SCS, etc.) typically focus on cabling schemes which provide for data and voice communications network infrastructures in office buildings, manufacturing facilities, educational institutions, military installations and other nonresidential sites. Optical fiber has long been recognized as the cabling mainstay in the vertical (or backbone/riser) portions of these datacom networks.

However, in the horizontal (or wiring closet-to-the-desktop) subsystems arena, opposing sides continue to wage heated "copper vs. fiber" debates in the trade press. Although unshielded twisted-pair (UTP) currently reigns as the medium of choice in horizontal premise wiring, fiber optic cable is increasingly utilized because of decreasing materials costs, increasing ease of installation and consistently superior performance (i.e. signal quality,

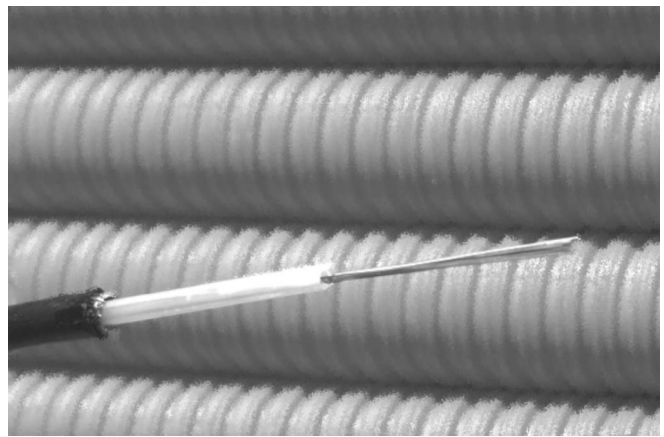

bandwidth, data rates, system reliability). According to the Business Research Group (Newton, MA), fiber's market share in new horizontal cabling installations has nearly tripled during the past three years, from 7% (1994) to 19% (1996). Other studies indicate that fiber optic cabling will be incorporated into more than 40% of new commercial premise wiring installations by the year 2000.

Although data and voice communications account for the majority of commercial premise wiring installations today, video cabling is becoming more prevalent due to the growing variety of applications including multimedia retrieval, distance learning, teleconferencing, education/training, business TV, entertainment and premises surveillance. While MPEG compression and ATM transmission techniques may be the ultimate LAN solutions for such "bandwidth-hungry" video applications, they are still embryonic, and, for most of us, unaffordable. In the meantime, LAN administrators are increasingly deploying separate overlay analog video networks to accommodate these exciting new video services.

"Bandwidth-hungry?" Video transmission requires the equivalent of extremely fast datacom transmission rates. One of two distinct transport capability levels can be found in any video network: baseband (or CCTV) or broadband (or CATV/MATV). A typical real-time uncompressed, unmodulated baseband video signal, as generated by a video camera or VCR, operates at a bandwidth of 4.2 to 6 MHz. This equates to 143 Mb/s or more if digitized (i.e. about 1,000 voice circuits), requiring a wiring medium of moderate capacity for high quality signal transmission. Broadband video signals, comprised of many individual baseband signals frequency-division multiplexed (FDM) together by VSB/AM modulation techniques, operate at even higher frequencies approaching 1,000 MHz of spectrum and require a very high capacity wiring medium.

## **Baseband Video and Fiber-to-the-Desktop**

A closed-circuit television or CCTV system is a private, usually in-plant, point-to-point video distribution (or contribution) system not involving broadcasting but which transmits to one or more receivers through a cable. Baseband signal distribution transports video, audio and/or data (V/A/D) signals directly between two points, providing

greater privacy and security than broadband distribution alternatives.

In a *video contribution* scenario utilizing remote CCTV surveillance cameras, RG-59, RG-6 or RG-11 coaxial cable (with BNC connectors) is often used for short-to-medium distances (i.e. several hundred feet) because its electrical characteristics best match those required to transmit the full-signal baseband video bandwidth from the remote camera to the monitor. However, whenever camera and monitor are separated by longer distances, especially if EMI/RFI electrical interference to or from other sources is an inherent problem, quality CCTV signal transmission dictates fiber optic cabling (see Figure 1).

Point-to-point maximum video transmission distances over fiber vary widely, depending upon type of available optical fiber (multimode vs. single-mode) and optical wavelength (see Table I). If one also factors the ever-decreasing cost of these low-profile optoelectronic packages (\$450 and up for multimode fiber; \$850 and up for single-mode fiber), it is easy to understand fiber's current popularity and universal acceptance by the security and surveillance industry.

**Table I – Distance Capabilities: Baseband Video Transmission via Optical Fiber**

Description (Wavelength /Fiber Type)	Distance / Loss [ft. (m) / dB]	Model #/ Comment
AM Link (850 nm / MM)	13124 (4000)/14.7	2628/Loss Limited
FM Link (850 nm / MM)	6562 (2000)/8.6	2768/Bandwidth Limited
FM Link (1300 nm / MM)	49215 (15000)/18	2768/Bandwidth Limited
FM Link (1300 nm / SM)	167331 (51000)/18	2768/Loss Limited
FM Link (1550 nm / SM)	295290 (90000)/18	2768/Loss Limited

Using a low-cost video router switch in a multimedia *video distribution* scenario, 64 or more V/A/D baseband signals can be routed simultaneously from a single central location to hundreds of remote locations. This topology can be effectively deployed over multimode or single-mode optical fiber, and allows for economical upgrades to two-way videoconferencing with the activation of a dedicated return path fiber from the remote location (see Figure 2).

Because this architecture is fully supported by most major suppliers of remote multimedia retrieval and control systems (i.e. AMX, Crestron, DuKane, Rauland-Borg, etc.), scores of educational, corporate, government and military institutions have installed switched baseband video distribution networks utilizing fiber optic media in intrabuilding and interbuilding campus settings.

This video distribution approach is architecturally akin to "fiber-to-the-desktop" LAN topologies like AMP's Centralized Network Administration (CNA) in which all LAN network electronics (hubs, switches, routers and cable cross-connects) are consolidated into a centralized wiring closet rather than distributing them between floors, simplifying network management and decreasing hardware costs. Centralized topologies like CNA also take full advantage of the high-reliability and longer data transmission distances offered by optical fiber. (See *Fiber Optic Product News*,

"LAN Design Paradigm Reduces Operating Costs", May 1996).

One of the first field deployments of AMP's Centralized Network Administration is at a new Greensboro-area elementary school, opening August 1996, in Guilford County, North Carolina. The system boasts a centralized wiring closet with multimode fiber runs to Ethernet hubs in each classroom. The installation also features a 48 x 48 **inFOXpressway** switched baseband video distribution network with multimode fiber runs from 48 A/V sources to low-cost optical receivers in each of 48 classrooms. Video backfeed circuits from a number of specified classrooms provide for real-time videoconferencing within the network, or with the outside world.

*Using a low-cost video router switch in a multimedia video distribution scenario, 64 or more V/A/D baseband signals can be routed simultaneously from a single central location to hundreds of remote locations.*

### Baseband Video and UTP

In July 1991, the now-universally-accepted (ANSI) TIA/EIA-568-A Commercial Building Cabling Standard was first published to help define and standardize physical layer building telecommunications infrastructure (i.e. cabling topologies, media, components, interfaces, etc.) for LAN communications in office environments. Among the many facets of this evolving document, the standard recognizes four types of LAN cabling media: (1) 24 AWG Cat 3 and Cat 5 UTP; (2) 22 AWG Shielded Twisted Pair; (3) 62.5/125 micron graded-index multimode optical fiber, and; (4) single-mode optical fiber.

In effect, TIA/EIA-568-A obsoletes coaxial cable as a data/voice transmission medium in new LAN installations, grandfathering only the pre-1991 installed base of 50-Ohm datacom coaxial cable. The elimination of coax in favor of twisted pair is due to a number of obvious advantages, including smaller cable size, less weight, easier installation and lower cost. In addition, without the guidelines established by EIA/TIA-568-A which facilitate cable management, coax installations tend to be *ad hoc*, making LAN changes, additions and moves more difficult to plan and implement with coax than with UTP.

Although baseband video has traditionally been transmitted over 75-Ohm coaxial cable, it can also be transmitted over UTP aboard the same wiring infrastructure which transports voice and data in TIA/EIA-568-A environments. By utilizing a pair of low-cost video baluns (impedance matching devices which transform the unbalanced electrical signal that passes over coaxial cable to the balanced signal required by twisted pair, and vice versa), a high quality baseband V/A/D signal can be transmitted 300 meters or more over Cat 3 or Cat 5 UTP.

AT&T's (now Lucent Technologies) Model 380A Adapter is essentially a passive video balun with common-mode

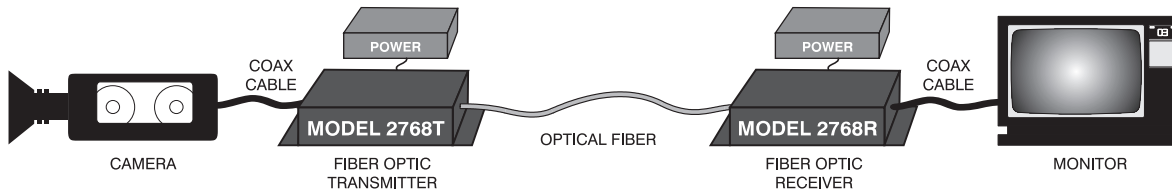

**Figure 1 - CCTV Video Surveillance via Fiber Optic Cabling**

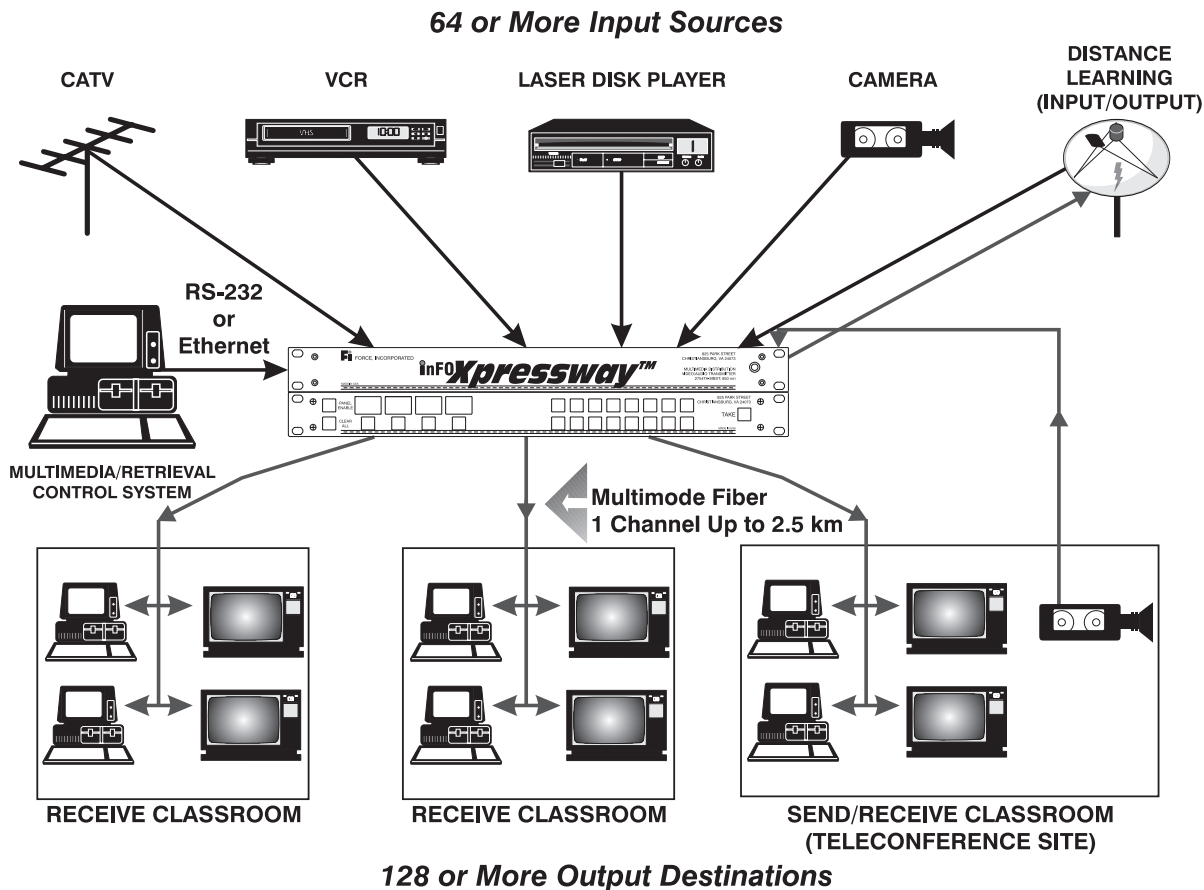

**Figure 2 - Switched Baseband Video Distribution via Fiber Optic Cabling**

filtering which converts a composite analog baseband video (< 8 MHz) and dual channel stereo audio (< 20 kHz) signals for transmission over the company's SYSTIMAX SCS structured cabling system for UTP. System accessories allow ganging of hardware for distribution of a baseband A/V signal to as many as 60 remote outlets.

Several active video balun product offerings have also recently been announced by other manufacturers which tout greater distance specs and immunity to EMI/RFI in harsh industrial environments.

### Baseband Video and Hybrid Fiber Copper

Obviously, the optimal video cabling scenario for structured premise wiring environments would be one which mimics the majority of today's data/voice installations: optical fiber in the backbone and unshielded twisted pair in the horizontal distribution to the desktop.

During December 1994, functional testing was conducted by AT&T Bell Labs (Middletown, NJ) to determine the maximum distances for baseband video transmission in fiber/UTP mixed media situations. The links consisted of combinations of AT&T SYSTIMAX SCS 62.5/125 micron multimode fiber, Cat 3 or Cat 5 UTP, 380A Adapters and Force, Inc. 850 nm multimode AM and FM video fiber optic transmitters/receivers and video/dual audio mux/demuxes (see Figure 3). The intent was to simulate a typical commercial LAN environment, with optical fiber in the backbone, and UTP to the desktop.

The follow-up January 1995 report from AT&T Bell Labs concluded that, "With FM optical devices, the links supported the full 6,562 foot (2000 meter) baseline distance of fiber plus the full 1,200 foot (365 meter) baseline distance of Category 3 or the full 1,500 foot (457 meter) baseline distance of Category 5 UTP using 380A Adapters...With AM optical devices, the links supported the full baseline distance of both Category 3 or Category 5 UTP using 380A Adapters but required a reduction in optical loss budget of about 2 dB or so. This translates into about a 500 meter distance decrease [from the baseline 4000 meter distance] in fiber distance capability. The decrease in optical power budget ensures full amplitude video signal out of the AM optical receiver and into the UTP adapters."

Extrapolating these findings to include longer wavelength FM transmitter/receiver pairs and/or single-mode fiber, it is not unreasonable to conclude that similar results can be obtained in situations which call for non-repeated V/A/D transmission requirements up to 90 km.

### Broadband Video and Fiber-to-the-Desktop

A cable television or CATV system employs a hard-wire cabling network as a point-to-multipoint broadcast video transmission medium from a common source to a large number of remote locations. Since 1948, an alternate acronym, MATV (Master Antenna TV system), has been applied to intrabuilding CATV-style broadband video distribution systems in commercial, campus or high-density residential settings.

Broadband signal distribution transports a number of individually modulated baseband V/A/D signals on a common cable that can be either coaxial, copper or optical

fiber. However, without the addition of passive filters or active electronics that limit access to all or some of these "channels", anyone on the broadband distribution path can tune in and view the broadcast.

The normal conduit for distributing broadband signals in MATV environments is 75-Ohm RG-59, RG-6 or RG-11 coaxial cable (with F-type connectors) driven by periodic in-line distribution amplifiers (to account for cable loss or attenuation) and wall "taps" located at appropriate locations for convenient TV connections.

As in the preceding discussion on baseband video, coax cable is the most popular cable-type used to transport a broadband video signal. However, video information transmitted via coax weakens (or attenuates) over distance. Furthermore, the rate of attenuation over distance is not linear, but is directly proportional to the frequency of the broadband signal. The higher the frequency, the more coax will attenuate the signal. In general, a given coaxial cable will generally triple the dB/100 ft. measurement of loss at 300 MHz (channel 36) as compared to 54 MHz (channel 2) (See Table II). In contrast, fiber attenuation is low, linear, and a function of optical wavelength, and normally measured in dB/km.

**Table II – Attenuation vs. Frequency: Coaxial Cable vs. Optical Fiber**

CATV Ch #	Freq. (MHz)	Attenuation (dB/100 feet)					
		Coaxial Cable			Optical Fiber		
		RG-59 /U	RG-6 Foam	RG-11 Foam	MM (62.5/125) 850 nm	SM 1300 nm	SM 1300 nm
2	55	1.78	1.44	0.93	0.123	0.032	0.016
A-2	108	2.48	2.02	1.30	0.123	0.032	0.016
13	216	3.48	2.85	1.83	0.123	0.032	0.016
36	300	4.13	3.37	2.17	0.123	0.032	0.016
62	450	5.13	4.17	2.69	0.123	0.032	0.016
78	550	5.72	4.65	3.01	0.123	0.032	0.016

Consequently, since maximum transmission distances for broadband via coax are only one-third those for baseband video over coax examined earlier, it is logical to assume that users will opt for optical fiber in favor of coax for broadband video transmission (as they have already done for baseband video transmission) once pricing parity has been established. In reality, this has already started to occur in a number of architectural scenarios.

Since the introduction of the first DFB laser-based broadband links in the early 1990's, the cost of CATV-style VSB/AM fiber optic technology has decreased by a factor of 6, channel-loading capacity has doubled and video quality specifications (CNR, CSO, CTB) have improved dramatically. Today, fiber optic broadband links are no longer just for CATV system operators for headend interconnects or for launching signal into FTTF (Fiber-to-the-Feeder) neighborhood coaxial cable distribution nodes serving 500 to 2,000 home clusters.

For example, campus-wide, interbuilding broadband video distribution for TV broadcast and distance learning via single-mode FTTF (Fiber-to-the-Dorm) has become the norm (See Figure 4). With increased output power optical transmitters (> 8 mW DFB), high-capacity, low-cost optical receivers and low-loss single-mode optical tree splitters, an 80+ channel CATV/Linx broadband feed to 16 or more on-campus locations can be deployed for less than \$2,500

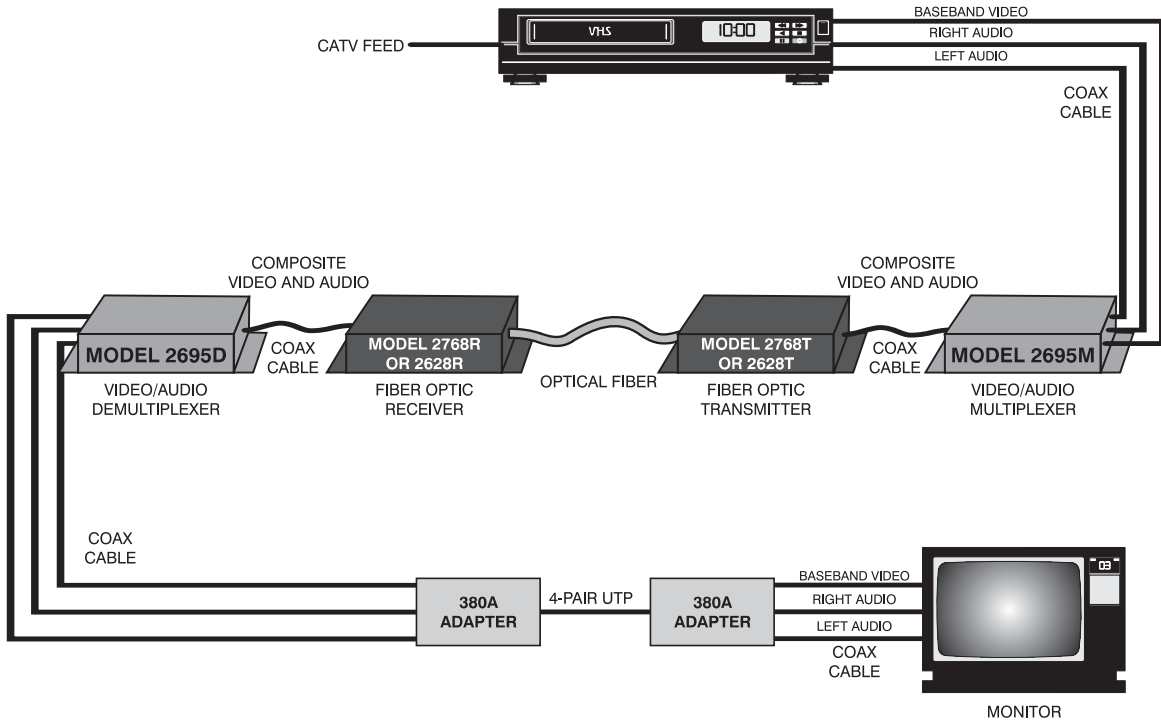

Figure 3 - Baseband V/A/D Transmission via HFC (Fiber UTP) Cabling

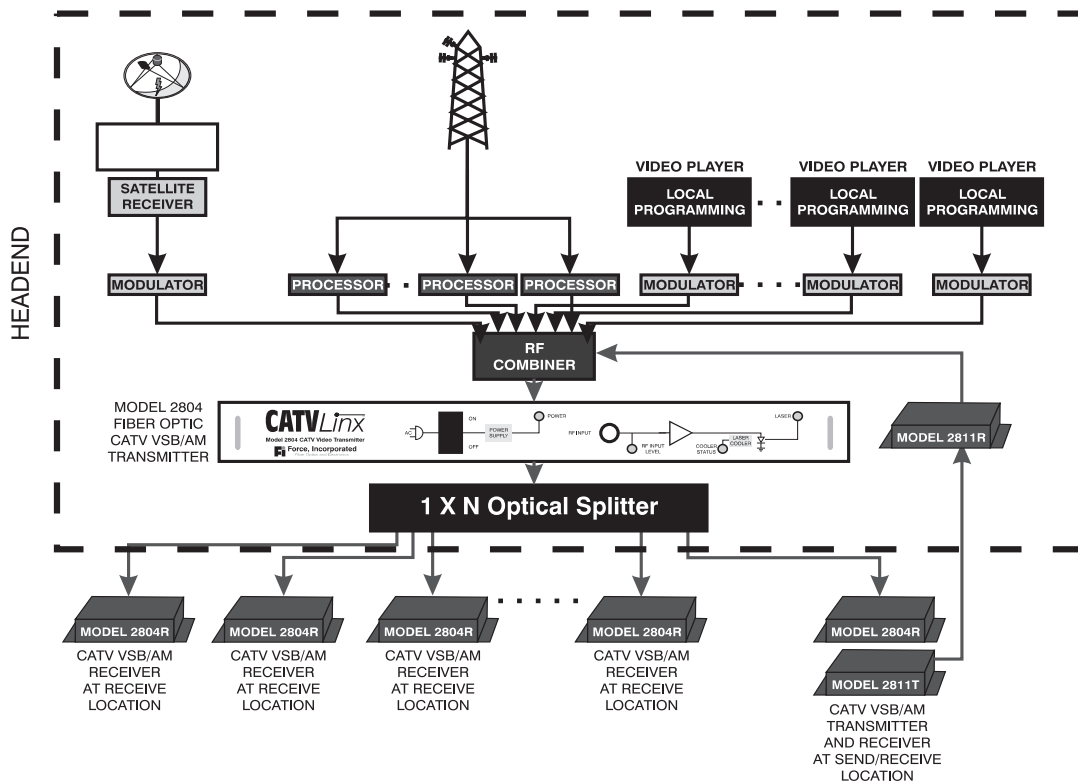

Figure 4 - Campus Broadband Video Distribution via Fiber Optic Cabling

per remote location. Low-cost Fabry-Perot laser **CATV<sub>Linx</sub>** enable from 4 to 18 channels of return path signal from remote sites for less than \$2,000 per location.

Finally, there are signs that broadband fiber is beginning to encroach into traditionally coax intrabuilding applications, all the way to the desktop. Utilizing LED-based **CATV<sub>Lite</sub>** fiber links to transport up to 10 broadband channels over 1 to 3 km of multimode fiber, hundreds of commercial, military and educational users have begun to utilize their existing LAN fiber network for multichannel broadband video transport, starting at less than \$500 per link.

### Broadband Video and UTP

Since the 1991 introduction of the TIA/EIA-568-A Commercial Building Cabling Standard, several innovative products from major manufacturers have been developed to provide horizontal intrabuilding connectivity via twisted pair for the delivery of broadband video to the desktop.

In 1992, IBM introduced the "F-Coupler", a system designed for delivering 500 MHz of RF spectrum (i.e. 70 CATV channels) over Type 1 shielded twisted pair (STP). The system was originally designed to support the IBM PS/2 TV tuner product that allowed the IBM PS/2 computer to function as a TV set.

Two years later, AT&T Network Systems rolled out the 384A Video Adapter for broadband video transmission over Category 5 UTP, as a part of its SYSTIMAX Structured Cabling System. Like its cousin, the 380A Adapter for baseband video discussed earlier, the 384A is a balun device which performs common mode filtering, balancing and impedance matching to provide connectivity between RF coax and Cat 5 4-pair UTP, and vice versa. With a nominal receive signal level of 0 dBmV (1 mV), the 384A transports multiple bidirectional broadband video channels (55-547.25 MHz) with CNR > 60 dB. Channel loading capability is 77 channels at 60 meters and 28 channels at 100 meters.

*Since the introduction of the TIA/EIA-568-A Commercial Building Cabling Standard, several innovative products from major manufacturers have been developed deliver broadband video to the desktop.*

In 1996, AMP Incorporated introduced its "Multimedia System" which delivers 28 bidirectional video channels (5-216 MHz) over Cat 5 UTP, and features fault-tolerant operation, "plug-and-play" wiring management and connectivity for telephone lines. In addition to a "breakout box" which provides a simple wall outlet connection for each remote user, self-configuring master and slave multimedia hubs provide for wire management at the wiring closet(s) and orderly expansion capabilities to 1,000 intrabuilding outlets.

Ed Kopakowski is the vice president of Sales & Marketing for Force, Incorporated. He originally prepared the paper from which this article is excerpted for the August 1996 issue of *Fiber Optic Product News*.

### Broadband Video and Hybrid Fiber Copper

In the Local Loop, the "other" HFC (hybrid fiber/coax) architecture is the current medium of choice for most CATV MSOs and several telephone companies for delivery of broadband services, including one-way and interactive video, to residential customers.

In commercial applications, a growing number of new installations are experiencing a similar phenomenon as the installed base of TIA/EIA-568-A-compliant installations continues to expand. Multimode fiber (up to 10 channels) and single-mode fiber (12 to 80+ channels) provide for vertical riser/backbone distribution of high-quality broadband signals. These signals can be sent directly to the desktop, or handed off at one or more telecommunications closets to a previously discussed UTP system for horizontal distribution to the desktop. Cost of installation is comparable to, or significantly lower than coax, especially if fiber/UTP is already in place for the LAN.

### Summary

The impact of TIA/EIA-568-A on premise wiring applications is widespread, and not just limited to data and voice communications. Innovative new product offerings from major suppliers, featuring optical fiber-to-the-desktop, UTP and hybrid combinations of the two, promise to make high-quality baseband and broadband video transmission an economical "plug-and-play" proposition in intrabuilding structured wiring environments. Stay tuned...

**Table III – Video Cabling Alternatives for Premise Wiring: Fiber Optic Cabling**

	Multimode	Single-mode
<b>Cost</b>	High	High
<b>Wiring Mgmt.</b>	Very Good	Very Good
<b>EMI/RFI Immunity</b>	Excellent	Excellent
<b>Bandwidth</b>	High	Very High
<b>"Future-Proof"</b>	Yes	Yes
<b>Picture/Signal Quality</b>	Very Good	Excellent
<b>Baseband Video</b>	1 channel 2-15+ km	1 channel 90+ km
<b>Broadband Video</b>	10+ channel 1-3+ km	80+ channels 20+ km

**Table IV – Video Cabling Alternatives for Premise Wiring: Copper Cabling/HFC**

	Copper Cabling		HFC
	UTP	Coax	Fiber/UTP
<b>Cost</b>	Low	Medium	Medium
<b>Wiring Mgmt.</b>	Excellent	Poor	Very Good
<b>EMI/RFI Immunity</b>	Poor/Good	Good	Good
<b>Bandwidth</b>	Low/Medium	High	High
<b>"Future-Proof"</b>	No	No	Partially
<b>Picture/Signal Quality</b>	Good	Good	Good
<b>Baseband Video</b>	1 channel 365-457 m	1 channel 170-365 m	1 channel 2-90+ km
<b>Broadband Video</b>	28-77 channel 60-100 m	60-80+ channel 45-120 m	10-80+ channel 1-20+ km