

EL1-002

EL1-002 (2004-02-25)

ebi_karimi@hotmail.com

0

:

() *
() *
() *
*

¹ The vernier caliper
² Micrometer
³ Spherometer

∴

() (MKS) ✓

() (cgs) ✓

(2.54cm) ✓

1mm

0.5mm

()

() ()

∴

✓

✓

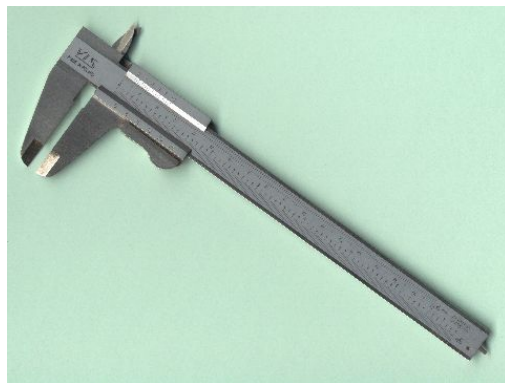

0.1mm ❶

0.02mm ❷

9mm

d_i . $d_i = 0.9 \times i$

0.9mm, 1.8mm, ...

49mm

i^{th}

0.98mm, 1.96mm, ...

i^{th}

d_i $d_i = 0.98 \times i$

() .

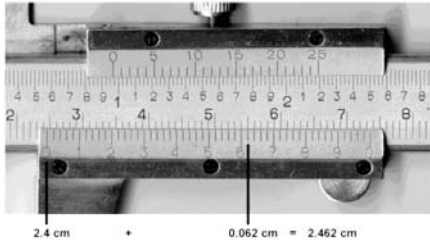

()

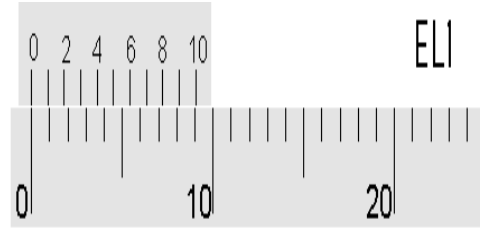

()

25mm 24mm () :

()

()

,6.2 ()

.(

$24\text{mm} + 0.62\text{mm} = 24.62\text{mm}$:

()
 0.5mm
 1mm
 () 0.5mm
 :
 0.01mm ①
 0.001mm ②
 0.5mm
 50
 0.09mm
 0.01mm
 0.01mm ()
 () 10
 0.001mm

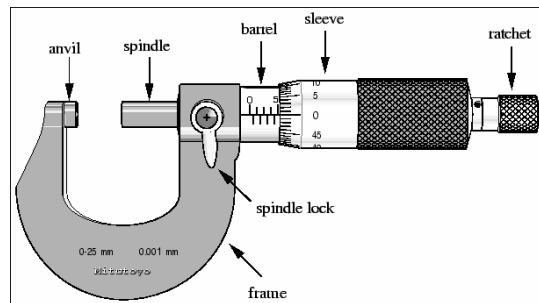
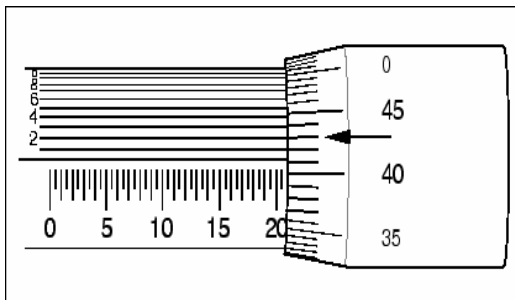

:
 5mm
 50)
 (20.5mm
 ()
 (0.40mm 0)
 20.90mm 5.00mm

(25mm)

4

()

) 1mm 100

.(

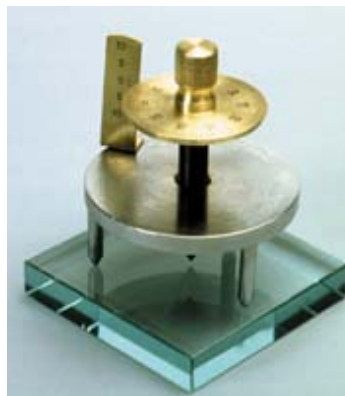

:

: ()

() ✓

)) (

(

:
:

3mm,4mm)

)
)

(

(0.54mm

.(3mm+0.54mm=3.54mm

:

(4mm,5mm)

(0.24mm)

5mm-)

.(0.24mm=4.76mm

()

.(0.01mm)

0.46mm

1mm

0.54mm