

CE 222— FINITE ELEMENT METHODS

PROBLEM SET #7

Problem 1

Previously you analyzed the beam below:

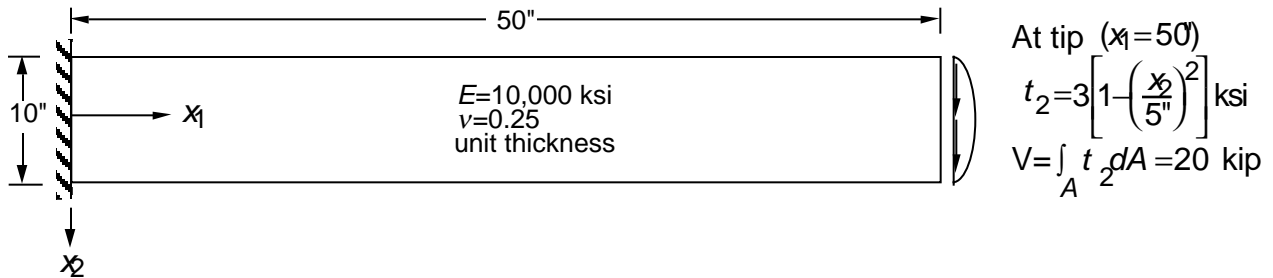

Use a 2x4 mesh of elements that may be distorted from a rectangular shape. Analyze the beam with undistorted mesh (D=0) with the distorted mesh (D=5) using three element formulations in FEAP:

- (a) 4-node elements
- (b) 4-node elements with enhanced strain
- (c) 9-node elements

For the six cases, comment on how the type of element and mesh distortion affects the accuracy of the finite element solution with regard to displacement at the tip, stresses at the fixed end, and strain energy.

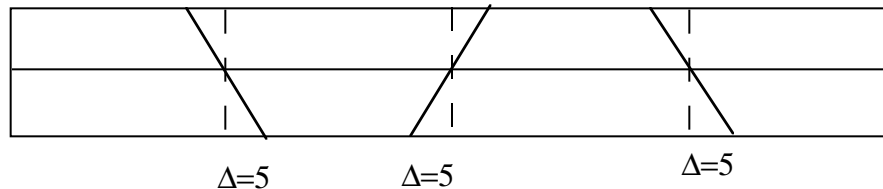

Problem 2

Perform the traction form of the patch test (for tractions in one direction only) for the following cases:

- (a) 4-node element, 2x2 integration, with enhanced strain
- (b) 9-node element, 3x3 integration
- (c) 9-node element, 2x2 integration
- (d) 8-node element, 3x3 integration
- (e) 8-node element, 2x2 integration

Problem 3

(a) Determine the shape functions (in natural coordinates) for the five node element shown below. Verify the sum of the shape functions is equal to unity.

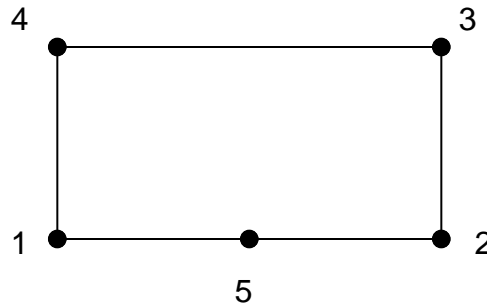

(b) A five–node element with the coordinates in the table below is subjected to the following displacement field: Nodes 1 to 4, zero displacement; Node 5, 1 in x_1 and 2 in x_2 . Compute the strain components at $\xi=\eta=0$ in the element.

Node	x_1	x_2	u_1	u_2
1	1	1	0	0
2	4	0	0	0
3	5	4	0	0
4	1	3	0	0
5	3	0	1	2

Problem 4

(a) Write the shape functions of a 3–node triangular element in the natural coordinate system as a special case of the 4–node isoparametric quadrilateral element.

(b) For the triangular element shown compute $|J(0,0)|$, the determinant of the Jacobian at $\xi=\eta=0$. Is this the value that you expect?

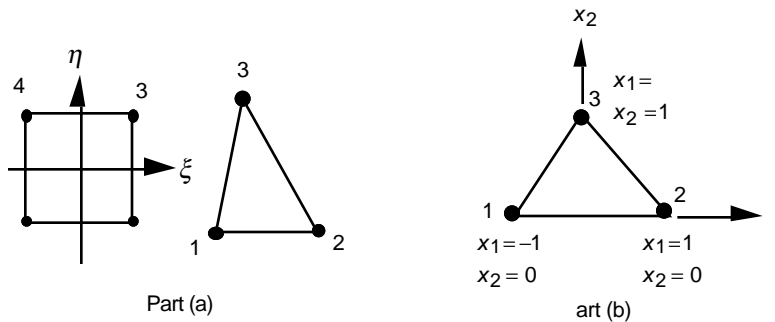

Problem 5

A gusset plate connects a diagonal brace to a beam–column joint. An idealization of the gusset plate is shown below. Assume the displacement boundary conditions with the beam and column are fixed, and the resultant axial force on the plate is 300 kips. Perform a finite element analysis of the plate subjected to the load from the brace. Plot the normal and shear traction along the boundaries with the beam and column. Do not use triangular elements in the mesh.

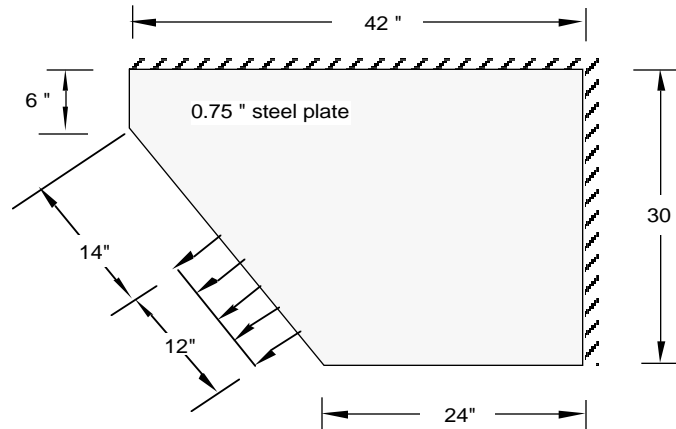

Notes on FEAP

The thickness of the element, the quadrature rule and the enhanced strain are defined in the material command. For example

```
mate,1
....
quadrature rule n1 n2
thickness body t
enhanced strain
```

defines an element with thickness t , quadrature rule $n1 \times n2$, stresses sampled at $n2 \times n2$ points and using enhanced strain modes.

The `csurf` command does *not* use the thickness of the element when computing the equivalent nodal loads