

Centauri Mogratti Battle Frigate

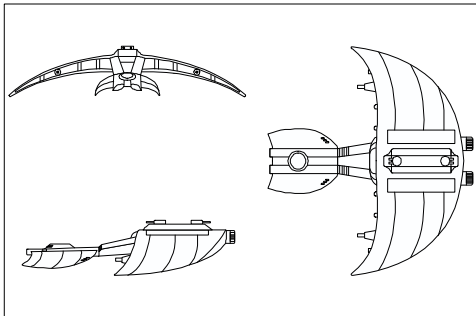

Rev: 1.1

SPECS

Classification: Medium Ship
 In Service: 2236
 Point Value: 575
 Ramming Factor: 60
 Jump Delay: N/A

MANEUVERING

Turn Cost: 1/3 x Speed
 Turn Delay: 1/3 x Speed
 Accel/Decel Cost: 2
 Pivot Cost: 2 Thrust
 Roll Cost: 2 Thrust

COMBAT STATS

Fwd/Aft Defense: 12
 Stb/Port Defense: 12
 Engine Efficiency: 2/1
 Extra Power: +2
 Initiative Bonus: +12

WEAPON DATA

Plasma Accelerator
 Class: Plasma 5
 Mode: Standard
 Damage: 4d10+12 (-1 per hex)
 Range Penalty: -1 per hex
 Fire Control: +3/+1-4
 Intercept Rating: N/A
 Rate of Fire: 1 per 3 turns
*Special: Can fire at an accelerated ROF for less damage, as shown below:
 1 per turn: 1d10+4 - 1/hex
 1 per 2 turns: 2d10+8 - 1/hex*

Matter Cannon
 Class: Matter 4
 Mode: Standard
 Damage: 2d10+2
 Range Penalty: -1 per 2 hexes
 Fire Control: +3/+3-2
 Intercept Rating: N/A
 Rate of Fire: 1 per 2 turns

Twin Array
 Class: Particle 2
 Mode: Standard
 Damage: 1d10+4
 Range Penalty: -2 per hex
 Fire Control: +4/+5/+6
 Intercept Rating: -2
 Rate of Fire: 2 per turn

Speed	1	2	3	4	5	6	7	8	9	10	11	12
Turn Cost	1	1	1	2	2	2	3	3	3	4	4	4
Turn Delay	1	1	1	2	2	2	3	3	3	4	4	4

FORWARD HITS

1-3: Retro Thrust
 4-5: Plasma Accelerator
 6-8: Matter Cannon
 9-11: Twin Array
 12-17: Structure
 18-20: PRIMARY Hit

AFT HITS

1-8: Main Thrust
 9-17: Structure
 18-20: PRIMARY Hit

PRIMARY HITS

1-7: Port/Strb Thrust
 8-9: Guardian Array
 10-12: Sensor
 13-15: Engine
 16: Hangar
 17-19: Reactor
 20: C & C

SPECIAL NOTES

Agile Ship

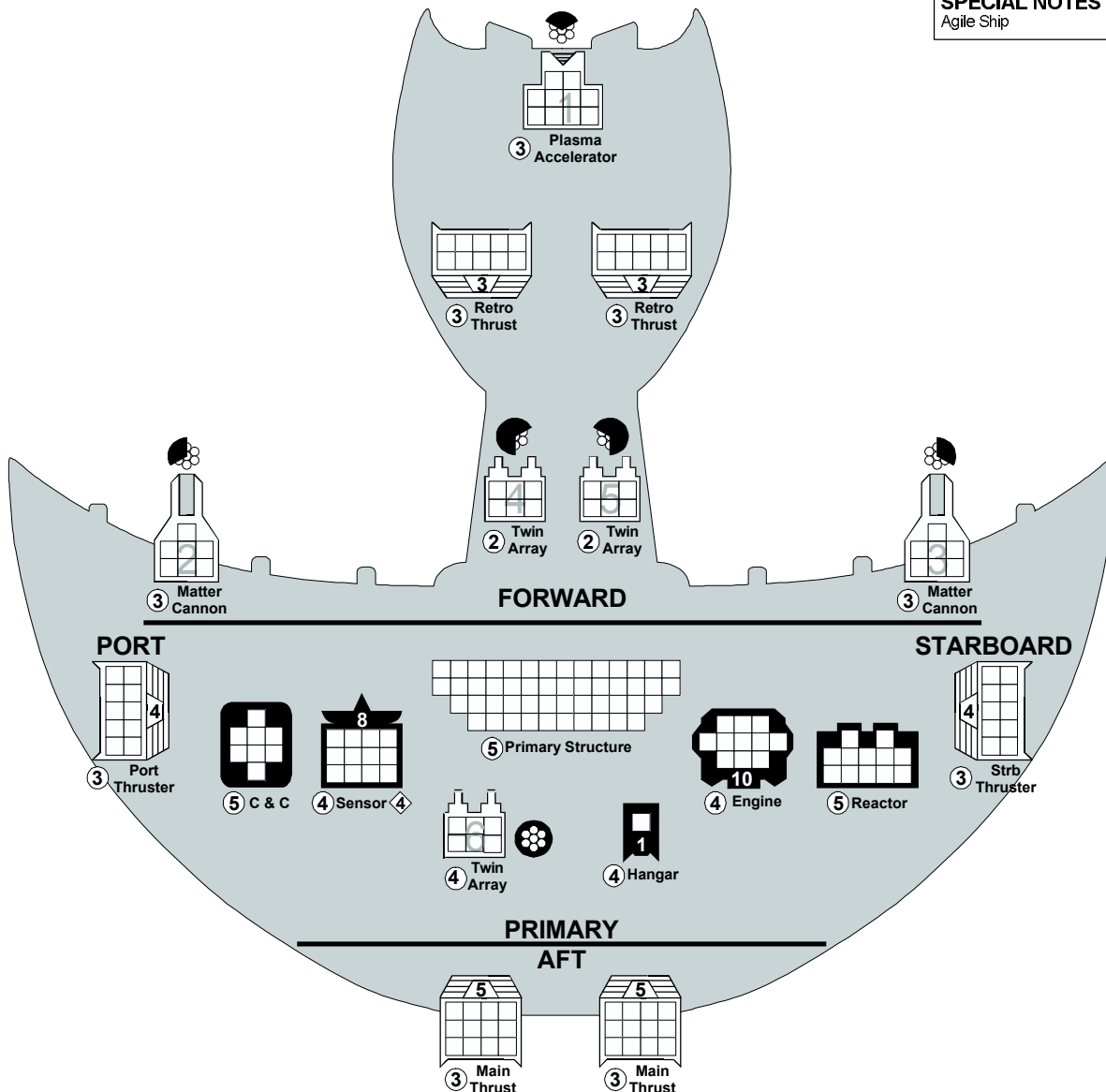

SENSOR DATA

Defensive EW		
Target #1		
Target #2		
Target #3		
Target #4		
Target #5		
Target #6		

HANGAR

0 Fighters
 1 Shuttle Thrust: 4
 Armor: 0 Defense: 8/10

--	--	--	--	--	--	--	--	--	--