

Module 2: Computer-System Structures

- Computer System Operation
- I/O Structure
- Storage Structure
- Storage Hierarchy
- Hardware Protection
- General System Architecture

Computer-System Architecture

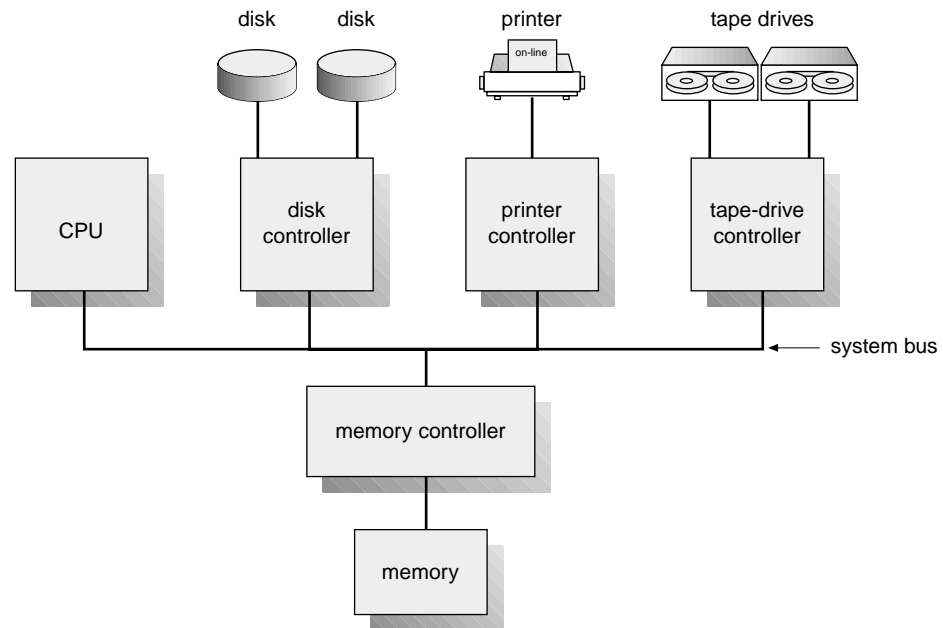

Computer-System Operation

- I/O devices and the CPU can execute concurrently.
- Each device controller is in charge of a particular device type.
- Each device controller has a local buffer.
- CPU moves data from/to main memory to/from local buffers
- I/O is from the device to local buffer of controller.
- Device controller informs CPU that it has finished its operation by causing an *interrupt*.

Common Functions of Interrupts

- Interrupts transfers control to the interrupt service routine generally, through the *interrupt vector*, which contains the addresses of all the service routines.
- Interrupt architecture must save the address of the interrupted instruction.
- Incoming interrupts are *disabled* while another interrupt is being processed to prevent a *lost interrupt*.
- A *trap* is a software-generated interrupt caused either by an error or a user request.
- An operating system is *interrupt driven*.

Interrupt Handling

- The operating system preserves the state of the CPU by storing registers and the program counter.
- Determines which type of interrupt has occurred:
 - *polling*
 - vectored interrupt system
- Separate segments of code determine what action should be taken for each type of interrupt

Interrupt Time Line For a Single Process Doing Output

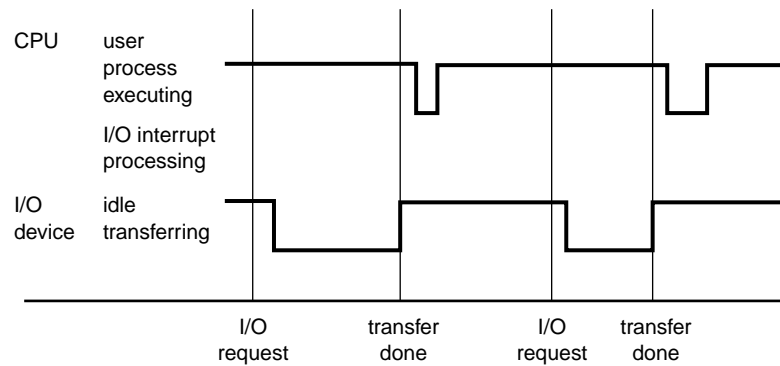

I/O Structure

- After I/O starts, control returns to user program only upon I/O completion.
 - wait instruction idles the CPU until the next interrupt
 - wait loop (contention for memory access).
 - At most one I/O request is outstanding at a time, no simultaneous I/O processing.
- After I/O starts, control returns to user program without waiting for I/O completion.
 - *System call* – request to the operating system to allow user to wait for I/O completion.
 - *Device-status table* contains entry for each I/O device indicating its type, address, and state.
 - Operating system indexes into I/O device table to determine device status and to modify table entry to include interrupt.

Two I/O methods

Synchronous

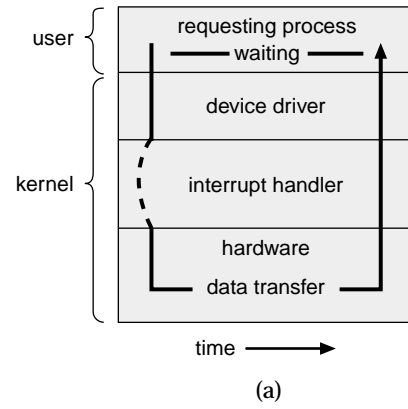

Asynchronous

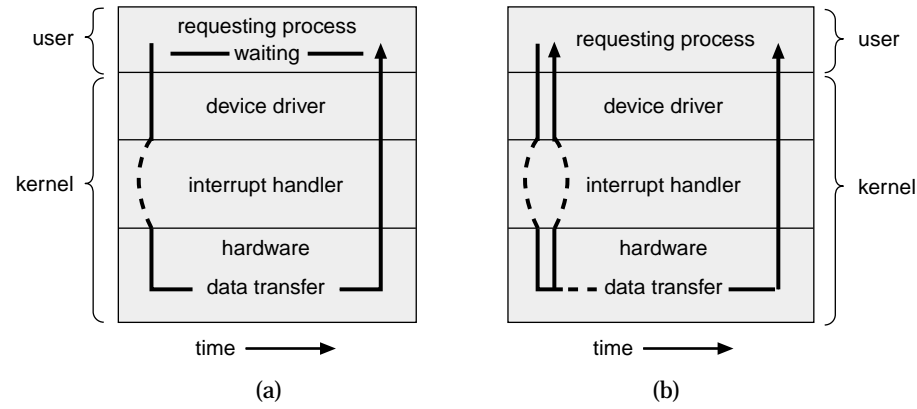

Device-Status Table

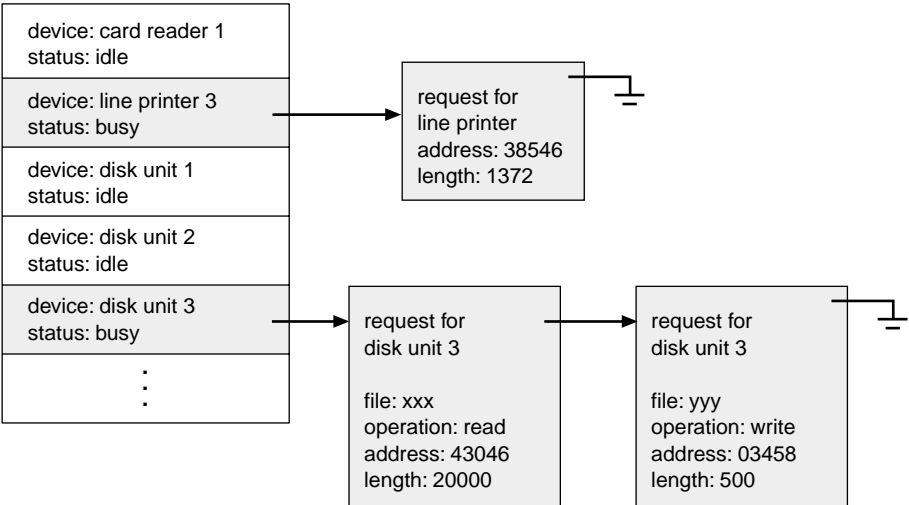

Direct Memory Access (DMA) Structure

- Used for high-speed I/O devices able to transmit information at close to memory speeds.
- Device controller transfers blocks of data from buffer storage directly to main memory without CPU intervention.
- Only one interrupt is generated per block, rather than the one interrupt per byte.

Storage Structure

- Main memory – only large storage media that the CPU can access directly.
- Secondary storage – extension of main memory that provides large nonvolatile storage capacity.
- Magnetic disks – rigid metal or glass platters covered with magnetic recording material
 - Disk surface is logically divided into *tracks*, which are subdivided into *sectors*.
 - The *disk controller* determines the logical interaction between the device and the computer.

Moving-Head Disk Mechanism

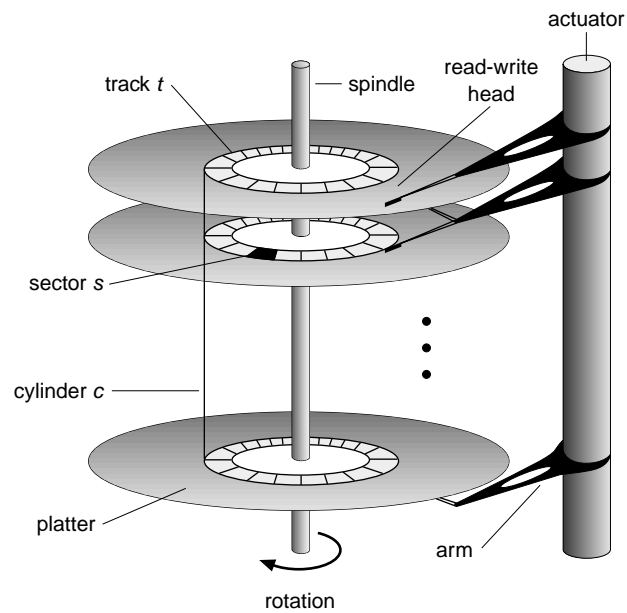

Storage Hierarchy

- Storage systems organized in hierarchy.
 - Speed
 - cost
 - volatility
- *Caching* – copying information into faster storage system; main memory can be viewed as a last *cache* for secondary storage.

Storage-Device Hierarchy

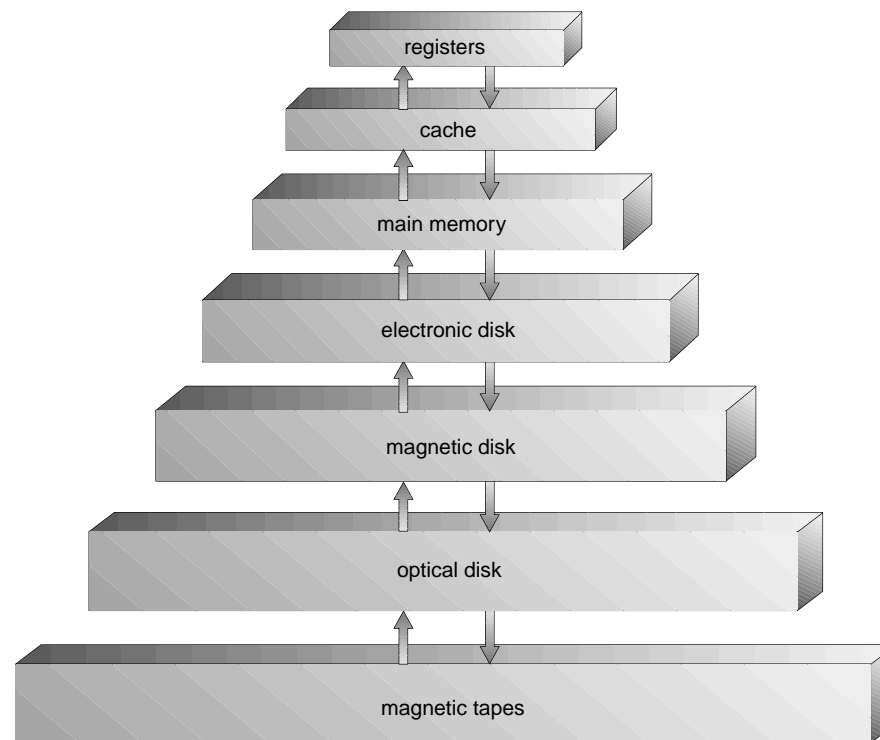

Hardware Protection

- Dual-Mode Operation
- I/O Protection
- Memory Protection
- CPU Protection

Dual-Mode Operation

- Sharing system resources requires operating system to ensure that an incorrect program cannot cause other programs to execute incorrectly.
- Provide hardware support to differentiate between at least two modes of operations.
 1. *User mode* – execution done on behalf of a user.
 2. *Monitor mode* (also *supervisor mode* or *system mode*) – execution done on behalf of operating system.

Dual-Mode Operation (Cont.)

- *Mode bit* added to computer hardware to indicate the current mode: monitor (0) or user (1).
- When an interrupt or fault occurs hardware switches to monitor mode.

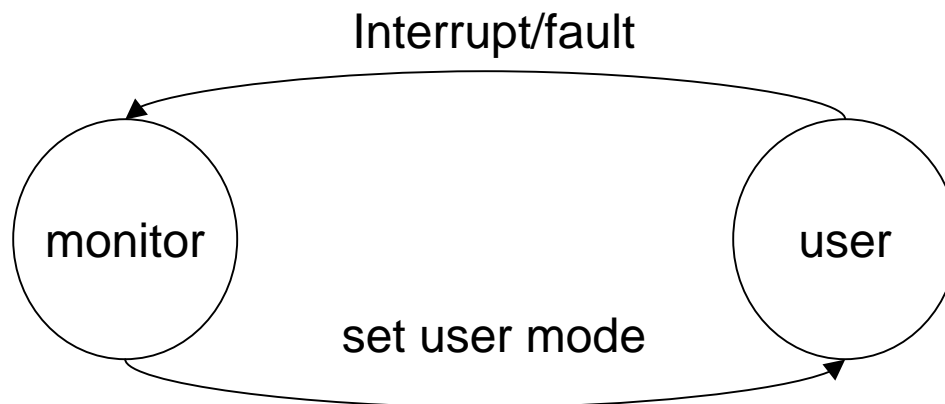

- *Privileged instructions* can be issued only in monitor mode.

I/O Protection

- All I/O instructions are privileged instructions.
- Must ensure that a user program could never gain control of the computer in monitor mode (i.e., a user program that, as part of its execution, stores a new address in the interrupt vector).

Memory Protection

- Must provide memory protection at least for the interrupt vector and the interrupt service routines.
- In order to have memory protection, add two registers that determine the range of legal addresses a program may access:
 - **base register** – holds the smallest legal physical memory address.
 - **Limit register** – contains the size of the range
- Memory outside the defined range is protected.

A Base And A limit Register Define A Logical Address Space

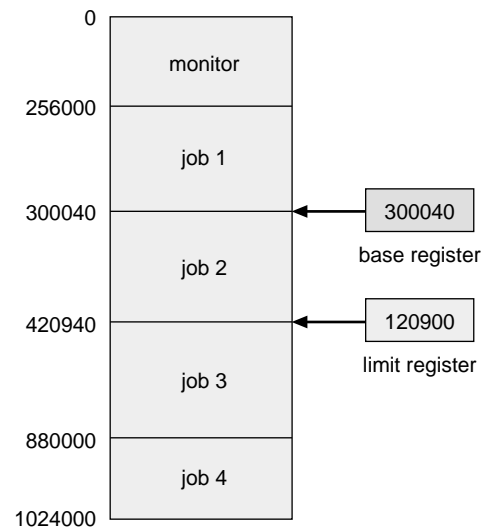

Protection Hardware

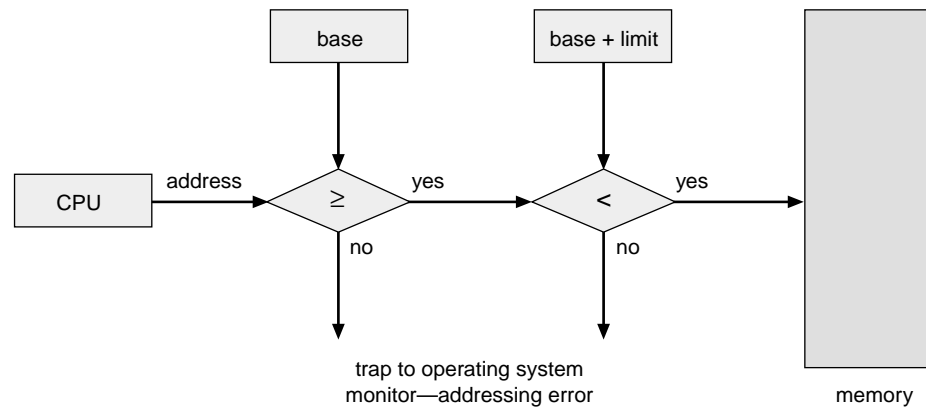

- When executing in monitor mode, the operating system has unrestricted access to both monitor and user's memory.
- The load instructions for the *base* and *limit* registers are privileged instructions.

CPU Protection

- *Timer* – interrupts computer after specified period to ensure operating system maintains control.
 - Timer is decremented every clock tick.
 - When timer reaches the value 0, an interrupt occurs.
- Timer commonly used to implement time sharing.
- Time also used to compute the current time.
- Load-timer is a privileged instruction.

General-System Architecture

- Given the I/O instructions are privileged, how does the user program perform I/O?
- System call – the method used by a process to request action by the operating system.
 - Usually takes the form of a trap to a specific location in the interrupt vector.
 - Control passes through the interrupt vector to a service routine in the OS, and the mode bit is set to monitor mode.
 - The monitor verifies that the parameters are correct and legal, executes the request, and returns control to the instruction following the system call.

Use of A System Call to Perform I/O

