

POWER METER IC

FEATURES

- Support IEC687/1036 50Hz/50Hz Alternating Current Watt-hour meters
 - Energy Data Less than 0.1% Over 1000:1 Dynamic range
 - Less than 0.1 degree Phase Error Between Voltage and Current Channel
 - Low Start-up Current.
- Direct Drive for Two Phase Stepper Motor
- High Frequency Output for Calibration
- Build-in Anti-aliasing Filter.
- 1, 2, 8, 16 Current Channel Gain.
- Digital Signal Processing; Operates in Extreme Environmental Condition
- On Chip Power Supply Monitoring
- Single +5 Volt Power Supply

Description

The AV7755 is a mixed signal monolithic CMOS integrated circuit for single phase alternating current watt-hour measurement. It is implemented with a two highly linear $\Sigma\Delta$ ADC for the voltage and the current sensors. The accuracy exceeds the IEC1036 and GB/T17215 specification.

The voltage and current signals are 256 times oversampled and then filtered and processed in the digital domain. The voltage and current information go through the identical paths; there are no phase mismatch between the two. This implementation guarantees the stability and accuracy required under extreme environmental condition and for all power factor measurements.

The IIN inputs are optimized for shunt sensor. It has a build-in four step gain amplifier, from 1.35, to 22 times. The current input voltage level, corresponds to basic current, I_b , can be less than 1 mv rms while the error is still within the IEC1036 specification.

The energy informations are converted to pulses and outputted via the CF, MP and MN pins. The MP and

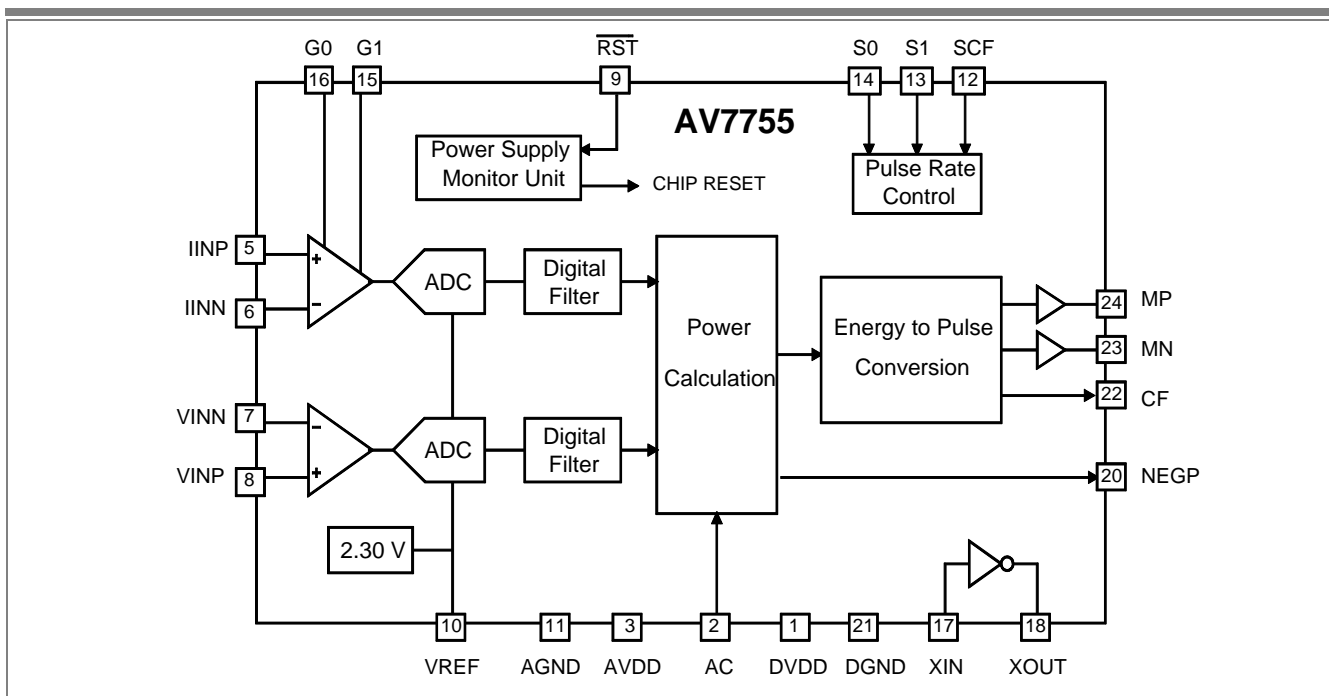

Performance Specification

Item		Input Range	Error @ 0.05 IB
1	Voltage	V={420 mVrms 42 mVrms}	< 0.5%
		Dynamic Range	10
2	Current (Figure 2 serial resistor = 1K)	Minimum Ib voltage = 0.5 mVrms	< 0.5%
		Max Differential Input Voltage without clipping: (IINP-IINN) * Gain.	600 mV.
		Dynamic Range:	1000
3	IMAX	Maximum Current	19 * Ib
4	Start-up Current		1.5% of Ib

- (1) Voltage and current are 50 Hz or 60 Hz sine wave with input voltage specified in the table
 (2) Clock frequency = 3.57554 Mhz.

AV7755

PIN ASSIGNMENT

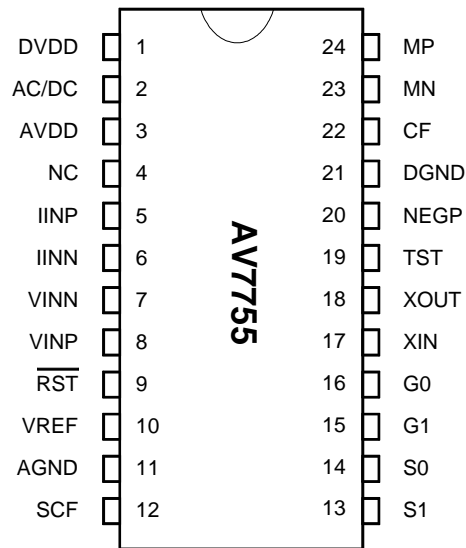

PIN DESCRIPTION

Pin Name	Pin #	Type	Description
DIGITAL			
DV _{DD}	1		Digital Power Supply. 5 Volt +- 5%. This pin should be decoupled with a 20 uF capacitor in parallel with a 0.1 uF ceramic capacitor.
AC/DC	2	I	High Pass Filter Select. For alternative current measurement this pin should be tied to DV _{DD} . 1: Enable the High Pass Filter. 0:Disable the High Pass Filter.
AV _{DD}	3		Analog Power Supply. 5 Volt +- 5%. This pin should be decoupled with a 20 uF capacitor in parallel with a 0.1 uF ceramic capacitor.
NC	4		No Connect
IINP, IINN	5, 6	I	Fully differential input for current channel. Maximum differential input is 0.7 Volt peak to peak. Maximum input level is 1 Volt with respect to AGND. Please refer to fig for input circuits.
VINN, VINP	7, 8	I	Fully differential input for current channel. Maximum differential input is 0.7 Volt peak to peak. Maximum input level is 1 Volt with respect to AGND. Please refer to fig for input circuits.
$\overline{\text{RST}}$	9	I	Reset Input Pin. This pin has an internal pull-up resistor.
VREF	10		Decoupling pin for the internal VREF signal. This pin should be tied to a 10 uF capacitor in parallel with a 0.1 uF ceramic capacitor.
AGND	11	GND	Analog Ground Pin.
SCF	12	I	Calibration Frequency Select.

PIN DESCRIPTION (Continued)

Pin Name	Pin #	Type	Description
S1,S0	13,14	I	MP and MF Pulse Frequency Select
G1,G0	15,16	I	Current Channel Input Gain Select (with serial resistor = 1K, as shown in Figure 2) 00: Gain = 1.375, 01: Gain = 2.7, 10: Gain = 11, 11: Gain =22.
XIN	17	I	Crystal oscillator input pin. For parallel resonant oscillator a capacitor between 22 pF to 33 pF should be tied between this pin and DGND.
XOUT	18	O	Crystal oscillator input pin. For parallel resonant oscillator a capacitor between 22 pF to 33 pF should be tied between this pin and DGND.
TST	19	I	This pin should be left open or tied to ground during normal operation.
NEGP	20	O	Negative Power Indicator.
DGND	21		Digital Ground Pin.
CF	22	O	Calibration Pulse Output Pin.
MP, MN	23, 24	O	Step Motor Driver Pin. The pulse frequency is determined by S1 and S2.

MN pins are designed to drive a two phase stepper motor directly.

Analog Input

The Av7755 includes two 19-bit $\Sigma\Delta$ ADC for current and voltage sensors. Before sensor signals are converted they are firstly filtered and amplified. The IIN, current, channel 's gain amplifier has the gain factors shown in the following table. The gains are selected via the G1 and G0 pins.

Analog Input Ranges

IIN Channel				
[G1,G0]	Gain		Max. Differential Input rms	
	R1 =1K	R1=2K	R1 =1K	R1=2K
[0, 0]	1.35	1.30	$\pm 311mV$	$\pm 325mV$
[0, 0]	2.7	2.6	$\pm 155mV$	$\pm 162mV$
[0, 0]	11	10.5	$\pm 39mV$	$\pm 40mV$
[0, 0]	22	21	$\pm 19.5mV$	$\pm 20.3mV$

R1 is the serial resistor shown in Fig.

VIN Channel		
	Min. Differential Input rms	Min. Differential Input rms
	$\pm 52mV$	$\pm 420mV$

The VIN, voltage channel, has a gain of one. The Maximum differential input is $\pm 600mV$. peak to peak.

The Capacitor C1 and C2 should be in the range of 500 to 100 pf.

Meter Constant

The meter constant for Av7755 is shown in equation (1).

$$Power = \frac{1.178 \times 10^4 \times Gain \times VI_{rms} \times VV_{rms}}{F} \quad (1)$$

where

Power is the power consumed in Kilo-Watt-Hours, Kwhrs, unit.

Gain is the amplification factor for the current channel,

VI_{rms} is the RMS voltage across the current sensor and *VV_{rms}* is the RMS voltage across the voltage sensor. Both *VI_{rms}* and *VV_{rms}* are in the unit of volts.

F is the frequency selection from table,

CCIR requires minimum of 100 pulses per Kilowatthour. The number of pulses per Kilowatthour is determined by equation (2)

$$\# \text{ of Pulses per hour} = Power \times F \quad (2)$$

F can be 100, 200, 400 and 800. It is determined by the setting of [S1 S0].

If the current shunt sensor is selected then the *VI_{rms}* is known the RMS of the differential voltage across VINP and VINN can be calculated by equation (3)

$$VV_{rms} = \frac{8.5 \times 10^{-3} \times F \times Power}{100 \times Gain \times VI_{rms}} \quad (3)$$

Design example

Power line voltage = 220 volt

I_{max} = 40 A

Shunt resistor = 300 $\mu\Omega$

F=100 impulse per Kwhrs

Gain = 22

At I_{max} the differential voltage across the INN and INP will be

$$VI_{rms} = 40 \times 300 \times 10^{-6} = 12 mV$$

within the maximum range of IIN specification.

$$Power = Line_Voltage \times Current = 220 \times 40 \text{ Whrs} = 8.8 \text{ Kwhrs}$$

Substitute the result into equation (2)

$$VV_{rms} = \frac{8.5 \times 10^{-3} \times 100 \times 8.8}{100 \times 22 \times 12 \times 10^{-3}} = 283.3mV$$

VV_{rms} is within the range of VIN specification.

Start-up Current and Power Monitor

The start-up current is about 0.15% of Ib. The AV7755 will not output any pulses on CF, MP and MN pins if the power supply fall below 4.0 Volt±5 %.

MP and MN Signals

The MP and MN are designed to drive electromechanical counter (stepper motor) directly. The pulse density is proportional to the average power measured. The output frequency can be multiplied to support different resolution counters. The output frequency is controlled by the S1 and S0 pins.

MP and MN Output Frequency

Item	[S1 S0]	# of Pulses per Kwhrs
1	[0 0]	100
2	[0 1]	200
3	[1 0]	400
4	[1 1]	800

Calibration Signal, CF

The CF signal is for calibration purpose. The output frequencies are either 12800 or 6400 pulses per Kwhrs. controlled by the SCF pin

CF Output Frequency

Item	SCF	[S1 S0]	# of Pulses per Kwhrs
1	1	[1 1]	2048x100
2	0	Others	128x100
3	1		64x100

Layout Consideration

The application should have three separated ground; the (a) power supply ground, (b) analog ground and (c) digital ground. The analog and digital planes should be solid planes, connected together at one point close to the chip. The power supply ground should be connected to the digital ground via a ferrite bead. The power supply ground should have solid traces but no planes on either side of PCB

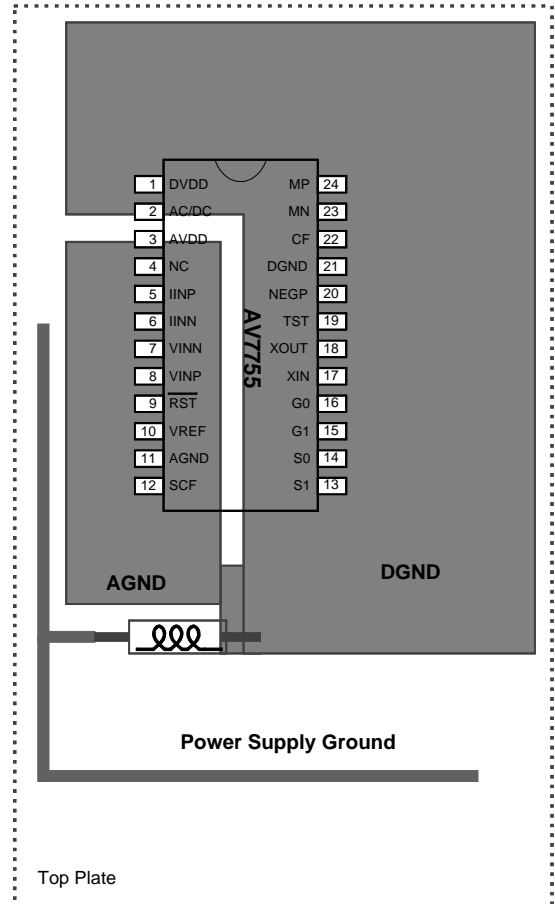

Timing Characteristics

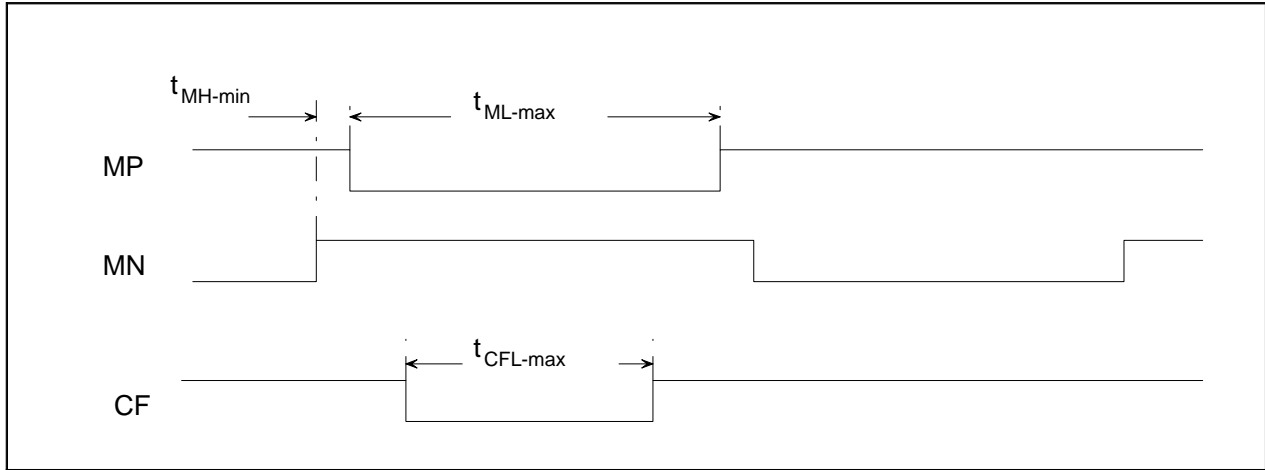

Figure 1. MP,MN and CF Timing Diagram

Parameters	timing	Descriptions
t_{MH-min}	500 nsec.	Minimum timing between MP (MN) high to MN (MP) low.
t_{ML-max}	120 msec.	Maximum MP or MN pulse low width.
$t_{CFL-max}$	80 msec.	Maximum CF pulse lows width

AV7755

Application Example

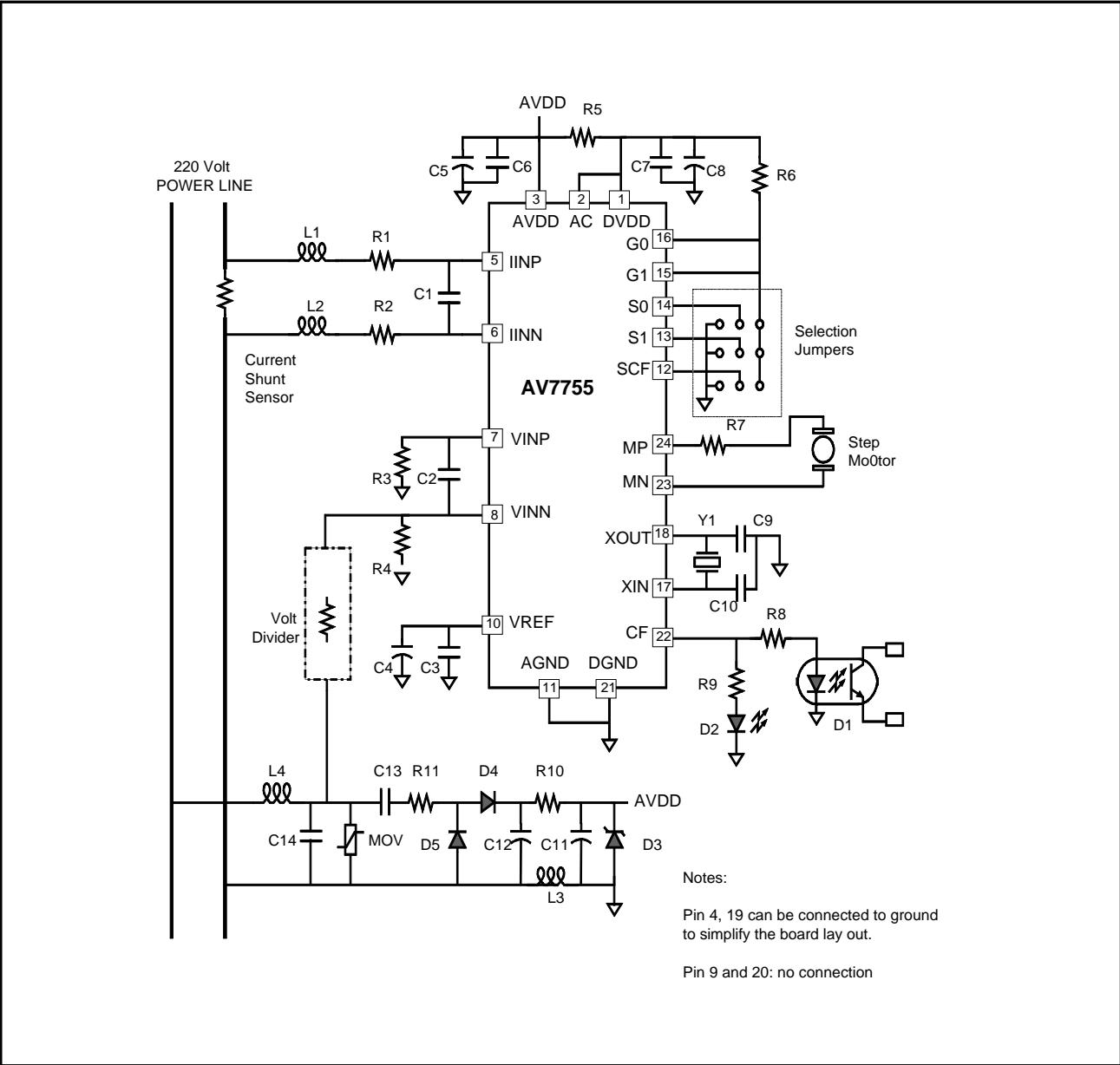

Figure 2. Typical Connection Diagram

AV7755

Bill of Materials

Parts	Specification	Descriptions
R1, R2, R3, R4	1K Ω , 1%, 1/8 watt	
R5	10 Ω , 5%, 1/8 watt	
R6, R9	4k Ω , 5%, 1/16 watt	
R7	30 Ω , 5%, 1/8 watt	
R8	820 Ω , 5%, 1/8 watt	
R10	100 Ω , 5%, 1/8 watt	
R11	470 Ω , 5%, 1 watt	
C1, C2	500 pF, Milliliter ceramic, 10%, 50 V.	
C3, C6, C7	0.1 uF, Milliliter ceramic, 10%, 16 V.	
C4	5 uF, 6.3 V.	
C5, C8	10 uF, 6.3 V.	
C9, C10	22 pF, Milliliter ceramic, 5%, 50 V.	
C11	470 uF, 10%, 16 V.	
C12	2200 uF, 10%, 16 V	
C13	470 nF, 250 V, AC	
C14	10 nF, 250 V, Class X2	
D1	NEC 2501 KF218	
D2	LED	
D3	Zener Diode, 5V, 1Watt	
D4, D5	Rectifying Diode, 1W, 400V	
MOV	270 V, AC, 140 Joules	
L1, L2, L3, L4	Ferrite Bead	
Y1	3.579545 Mhz,	Crystal Oscillator

ABSOLUTE MAXIMUM RATINGS

Symbol	Characteristics	Min	Max	Units
V_{DD}	Power Supply Voltage (Measured to GND)	-0.5	+7.0	V
V_i	Digital Input Applied Voltage ²	GND-0.5	$V_{DD}+0.5$	V
A_i	Digital Input Forced Current ^{3,4}	-100	100	mA
V_o	Digital Output Applied Voltage ²	GND-0.5	$V_{DD}+0.5$	V
A_o	Digital Output Forced Current ^{3,4}	-100	100	mA
TDsc	Digital Short Circuit Duration (single output high state to Vss)		1	Sec
TA _{SC}	Analog Short Circuit Duration (single output to VSS1)		infinite	Sec
V _{max}	Maximum Analog input Voltage		6	Volt
V _{min}	Minimum Analog input Voltage		-6	Volt
T_a	Ambient Operating Temperature Range	-25	+125	°C
T _{stg}	Storage Temperature Range	-65	+150	°C
T_j	Junction Temperature (Plastic Package)	-65	+150	°C
T _{sol}	Lead Soldering Temperature (10 sec., 1/4" from pin)		300	°C
T _{v_{sol}}	Vapor Phase Soldering (1 minute)		220	°C

Notes:

1. Absolute maximum ratings are limiting values applied individually, while all other parameters are within specified operating conditions.
2. Applied voltage must be current limited to specified range, and measured with respect to VSS.
3. Forcing voltage must be limited to specified range.
4. Current is specified as conventional current, flowing into the device.

RECOMMENDED OPERATING CONDITIONS

Symbol	Characteristics	Min	Typical	Max	Units
V_{DD}	Power supply voltage	4.75	5	5.25	V
DV_{DD}	Power supply voltage	4.5	5	5.25	V
V_{VCM}	Reference voltage	2.25	2.3	2.35	V
T_a	Ambient operating temperature range	0		70	°C

ELECTRICAL CHARACTERISTICS

Parameter	Characteristics	Min	Typ	Max	Units
Supply					
I_{DD}	Total Power Supply Current, Analog + Digital		5.25	5.75	mA
Digital Characteristics					
V_{IH}	Digital Input Voltage, Logic HIGH, TTL Compatible Inputs.	2.0		V_{DD}	V
V_{IL}	Digital Input Voltage, Logic LOW, TTL Compatible Inputs	0		0.8	V
I_{IH}	Digital Input Current, Logic HIGH, ($V_{IN}=4.0V$)			10	μA
I_{IL}	Digital Input Current, Logic LOW, ($V_{IN}=0.4V$)			-10	μA
C_{IN}	Digital Input Capacitance ($f=1Mhz$, $V_{IN}=2.4V$)			7	pF
V_{OH}	Digital Output Voltage, Logic HIGH, ($I_{OH}= -10$ mA)	4.0	4.5	DV_{DD}	V
V_{OL}	Digital Output Voltage, Logic LOW, ($I_{OL}=10$ mA)	V_{SS}		0.5	V
I_{OZH}	Hi-Z Leakage Current, HIGH, ($V_{DD}=Max$, $V_{IN}=V_{DD}$)			10	μA
I_{OZL}	Hi-Z Leakage Current, LOW, ($V_{DD}=Max$, $V_{IN}=V_{SS}$)			-10	μA
C_I	Digital Input Capacitance ($T^A=25^{\circ}C$, $f=1Mhz$)			8	pF
C_O	Digital Output Capacitance ($T^A=25^{\circ}C$, $f=1Mhz$)			10	pF

AV7755

Parameter	Characteristics	Min	Typ	Max	Units
Analog Inputs					
Amax	Maximum Signal Level with respect to AGND			1	V.
Smax	Maximum Differential Signal Input without Clipping		600		mV

PACKAGING INFORMATION

Dimensions

	MM.		Mils			MM.		Mils	
			min	max				min	max
A		533		210	E1	610	711	240	280
A1		.381		15	E2	762	825	301	325
b	.356	.558	14	22	e	254		100	
c	.21	.36	8	15					
D	28.8	32.3	1125	1275					

24-Pin (DIP)

