

:

CH₄

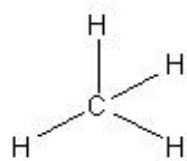

			:				
						(C)	1
(I)	(Br)	(Cl)	(F)	(H)			2
					(S)	(O)	3
					(P)	(N)	4

CH₄O

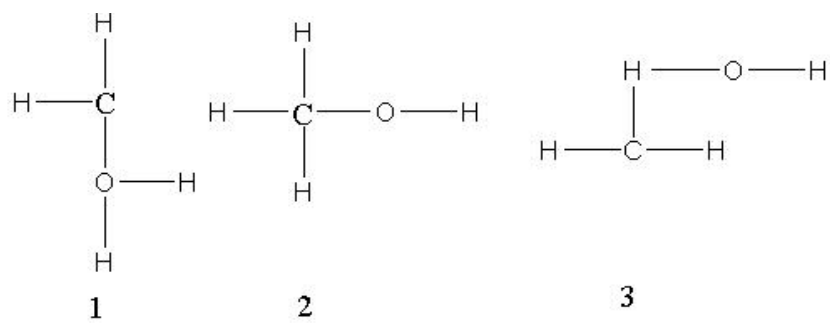

2

3

2

1



:

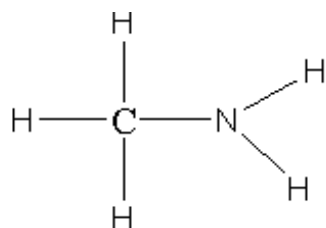

:

:

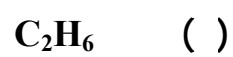

:

مقال	المجموعة الفعالة	الفصيلة
الايثان $\text{CH}_3\text{-CH}_3$	C-H و C-C	الألكانات
الاثيلين $\text{CH}_2=\text{CH}_2$	C=C	الألكينات
الأسيتيلين $\text{HC}\equiv\text{CH}$	-C≡C-	الألكاينات
الإيثانول $\text{C}_2\text{H}_5\text{-OH}$	C-OH	الكحولات
اثير ثنائي الميثيل $\text{H}_3\text{C-O-CH}_3$	C-O-C	الايثرات
الأسيتالدهيد $\text{H}_3\text{C-C(=O)-H}$	-C(=O)-H	الألدهيدات
الأسيتون $\text{H}_3\text{C-C(=O)-CH}_3$	C-C(=O)-C	الكيتونات
حمض الأسيتيك $\text{H}_3\text{C-C(=O)-OH}$	-C(=O)-OH	الأحماض الكربوكسيلية
أستات الاثيل $\text{H}_3\text{C-C(=O)-OC}_2\text{H}_5$	-C(=O)-O-C-	الاسترات
ميثيل أمين $\text{H}_3\text{C-NH}_2$	C-N-	الأمينات

(c)

(H)

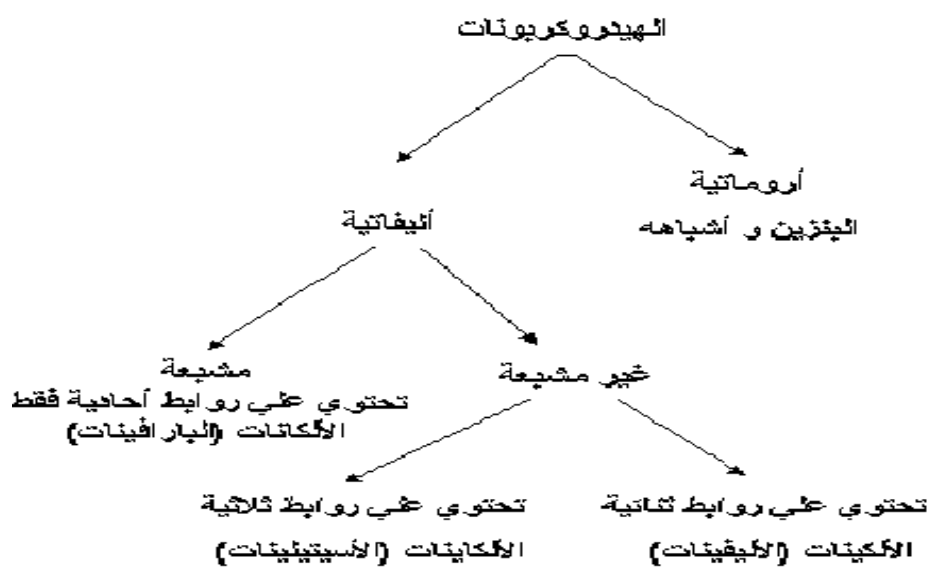



:

الصيغة البنائية	الصيغة الجزيئية	الاسم	n
CH ₄	CH ₄	الميثان	1
CH ₃ -CH ₃	C ₂ H ₆	الايثان	2
CH ₃ -CH ₂ -CH ₃	C ₃ H ₈	البروبان	3
CH ₃ -CH ₂ -CH ₂ -CH ₃	C ₄ H ₁₀	البيوتان	4
CH ₃ -CH ₂ -CH ₂ -CH ₂ -CH ₃	C ₅ H ₁₂	البنزان	5
CH ₃ -CH ₂ -CH ₂ -CH ₂ -CH ₂ -CH ₃	C ₆ H ₁₄	الهكسان	6
CH ₃ -CH ₂ -CH ₂ -CH ₂ -CH ₂ -CH ₂ -CH ₃	C ₇ H ₁₆	الهيبتان	7
CH ₃ -CH ₂ -CH ₂ -CH ₂ -CH ₂ -CH ₂ -CH ₂ -CH ₃	C ₈ H ₁₈	الأكتان	8
CH ₃ -CH ₂ -CH ₂ -CH ₂ -CH ₂ -CH ₂ -CH ₂ -CH ₂ -CH ₃	C ₉ H ₂₀	النونان	9
CH ₃ -CH ₂ -CH ₂ -CH ₂ -CH ₂ -CH ₂ -CH ₂ -CH ₂ -CH ₂ -CH ₃	C ₁₀ H ₂₂	الديكان	10

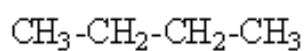
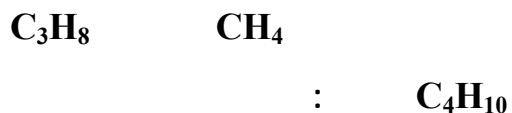

البيوتان العادي

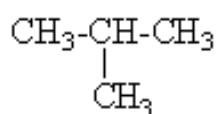

الأيزو بيوتان

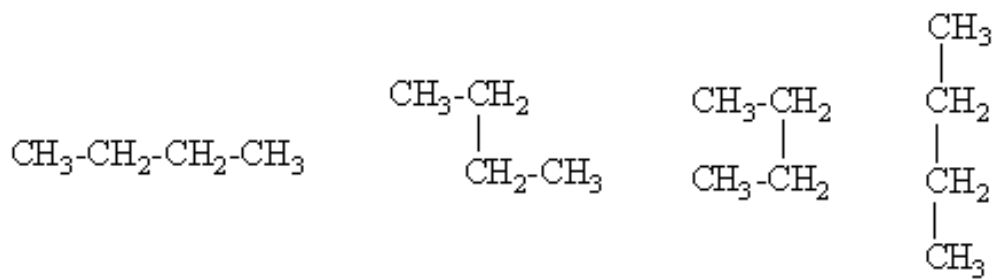
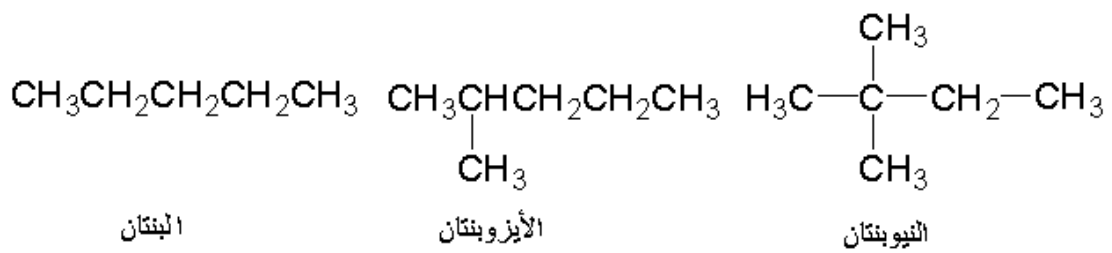

:

(5) C_6H_{14}

عدد المتشابهات	الصيغة الجزيئية	الاسم
1	CH ₄	الميثان
1	C ₂ H ₆	الايثان
1	C ₃ H ₈	البروبان
2	C ₄ H ₁₀	البيوتان
3	C ₅ H ₁₂	البنتان
5	C ₆ H ₁₄	الهكسان
9	C ₇ H ₁₆	الهيبتان
18	C ₈ H ₁₈	الأكتان
35	C ₉ H ₂₀	النونان
75	C ₁₀ H ₂₂	الديكان

IUPAC



IUPAC

:

International Union Of Pure and Applied Chemistry

:

.1

.2

.3

.4

(C₂H₅-)

(-CH₃)

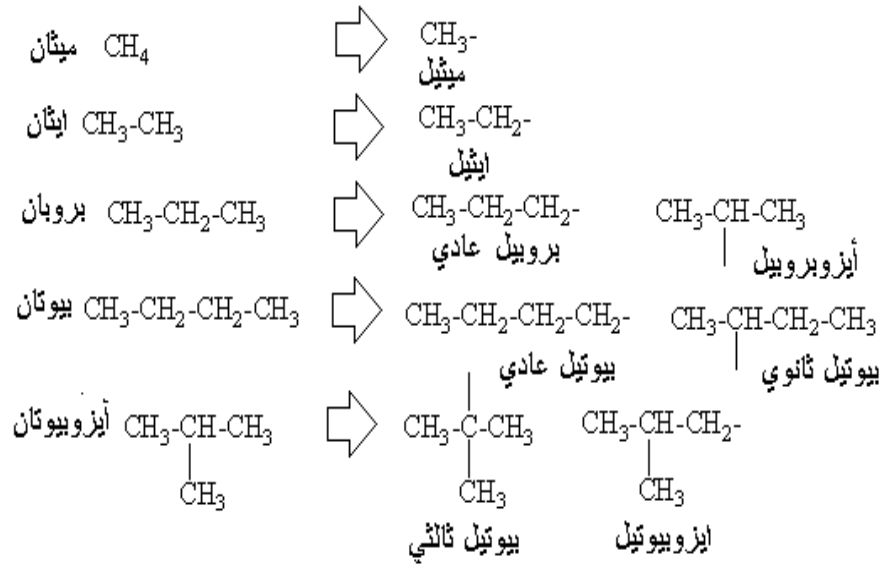

:

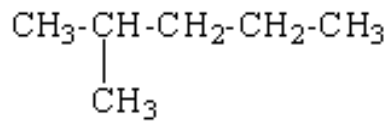

:

5 .1

2 (CH₃) .2

-2 .3

:

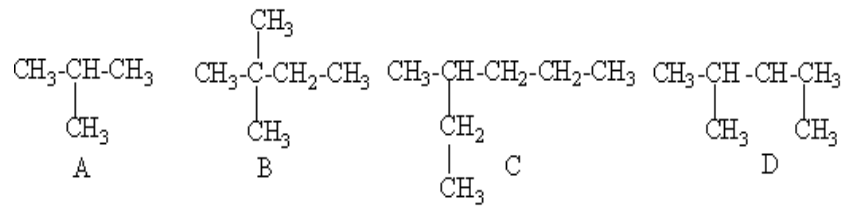

:

: A

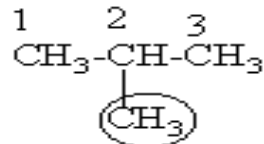

-2 (2)

: B

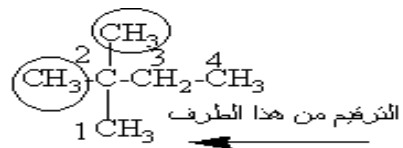

-2 2 (2)

(3)

: C



-3

: D



(C-H)

(C-C)

()

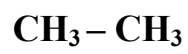

:



()

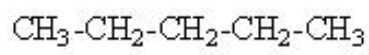

36.1°C

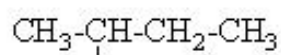

CH₃
27.8°C

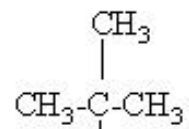

9.5°C

(H₂O)

()

.1

(Pt Ni)

.()

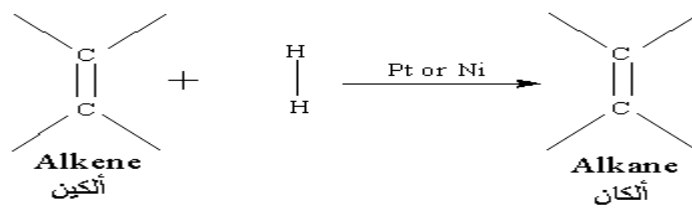

:

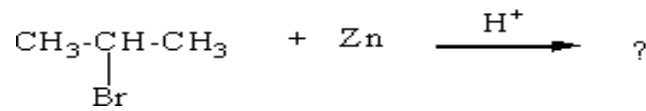
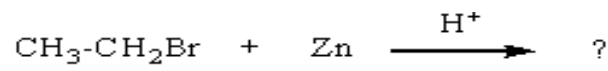

:

.(3)

:

.1

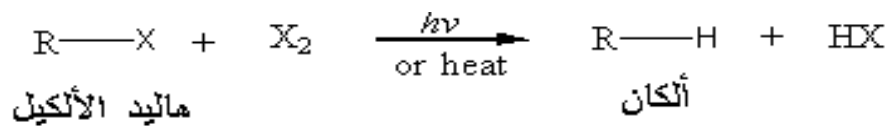
(F₂, Cl₂, Br₂, I₂)Cl₂.F₂I₂Br₂

:

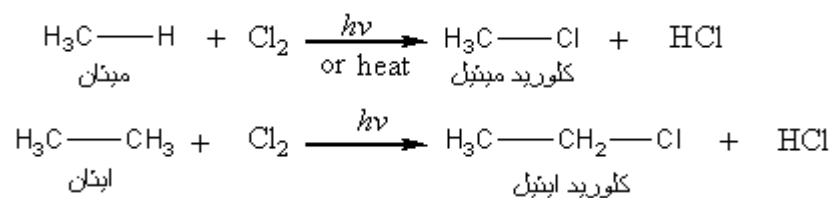

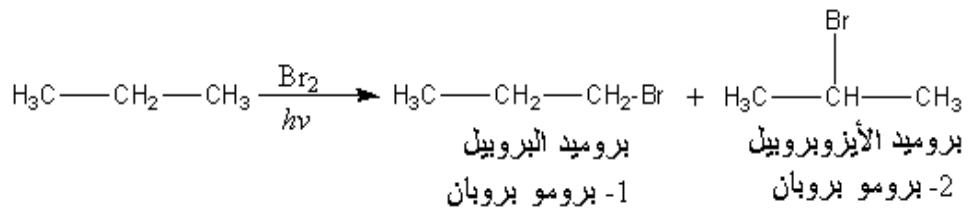
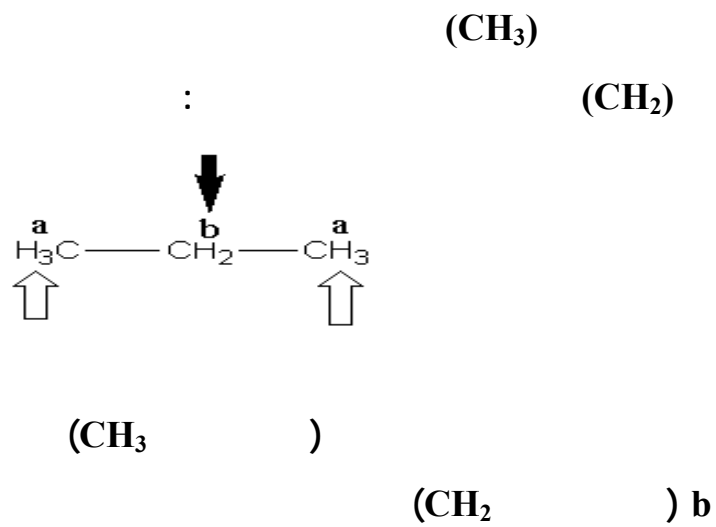

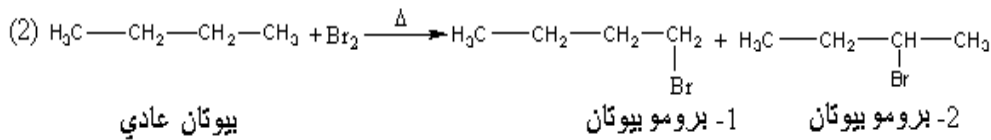
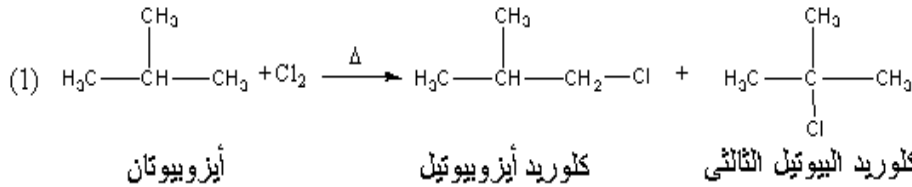
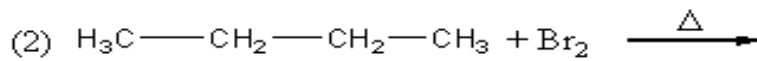
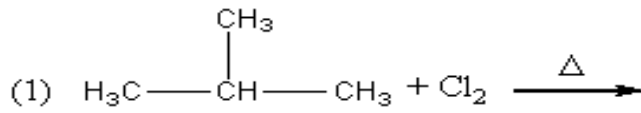
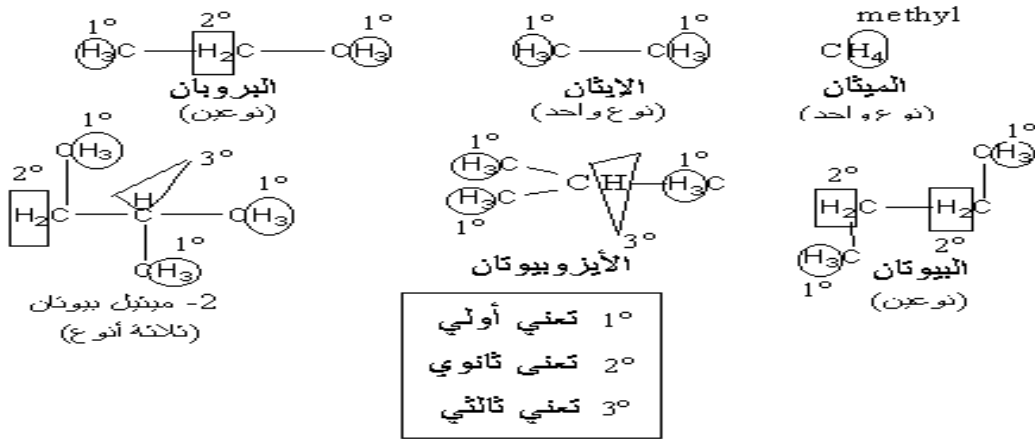

2. :

(H₂O)

(CO₂)

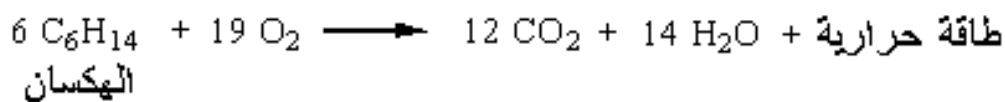

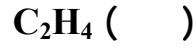

.

:

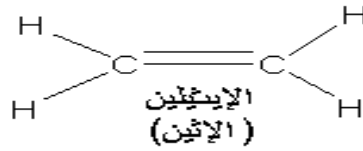

:

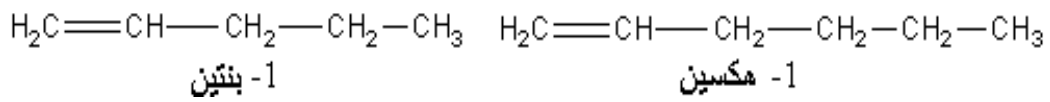
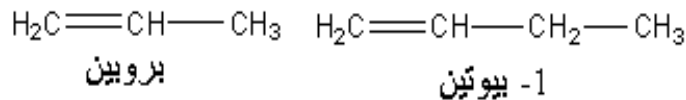

3 2

2 1

:

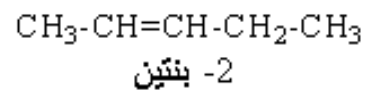
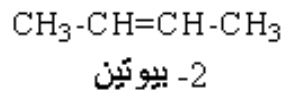

()

: ()

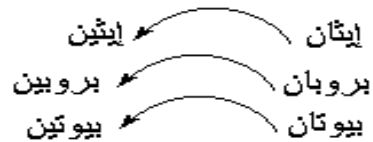

:

IUPAC

.1

.2

.3

.4

:

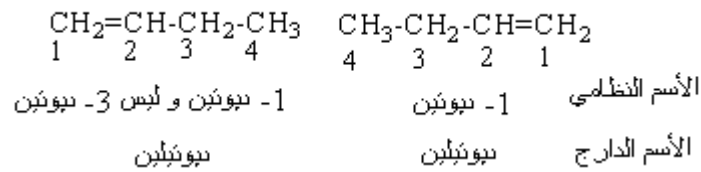
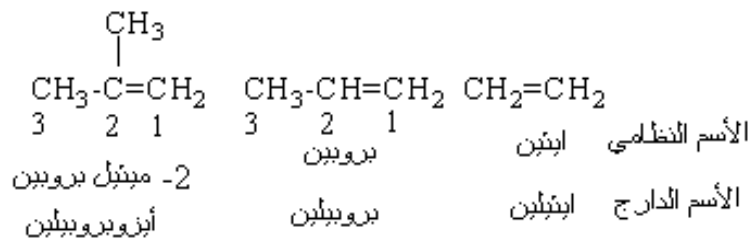

(IUPAC)

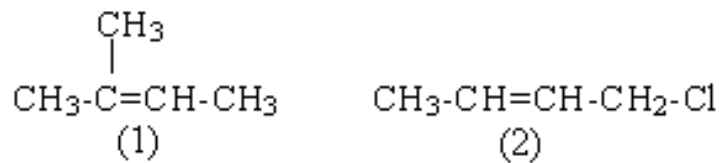

:

(1)

.1

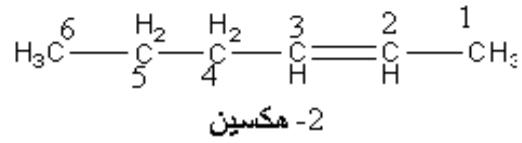
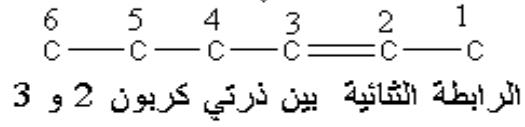
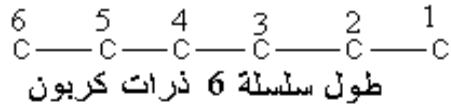

()

5 CH₃ ()

:

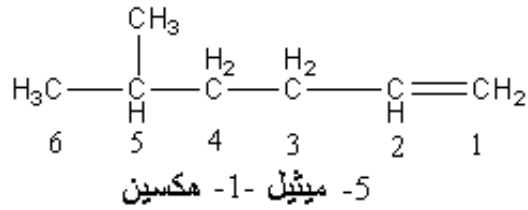
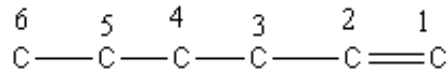

:(E/ Z /)

/

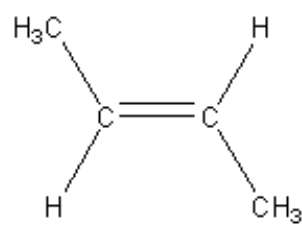

trans-2-Butene

ترانس -2- بيوتين

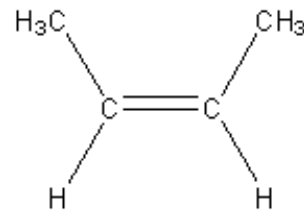

cis-2-Butene

سيس -2- بيوتين

(Cis)

(trans)

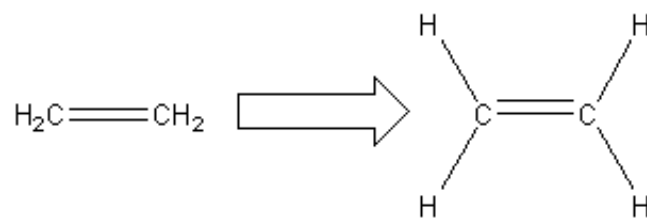

لا يوجد تشابه هندسي في الإثيلين

:

(H)

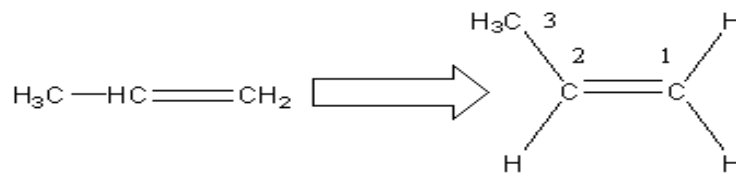

لا يوجد تشابه هندسي في البروبين

(1)

-1-



-1

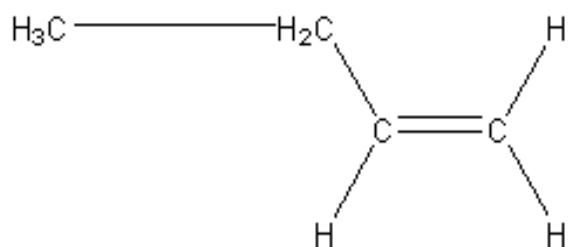

-1

-1-

-3 (/)

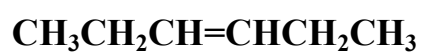

-3

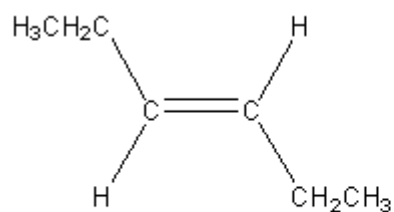

trans-3-Hexene

ترانس 3-هكسين

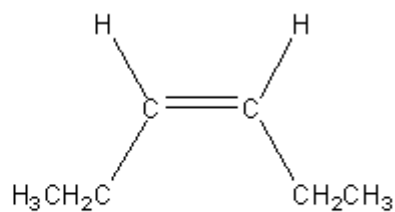

cis-3-Hexene

سيسز 3-هكسين

:

-1() -2- -2 () -2 ()

:

-1

:

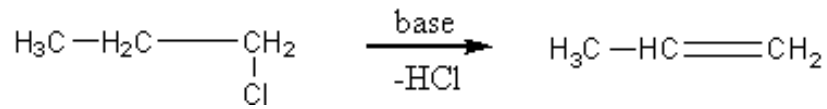
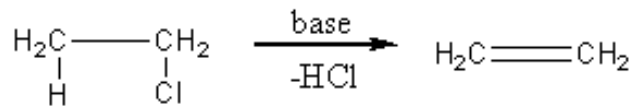
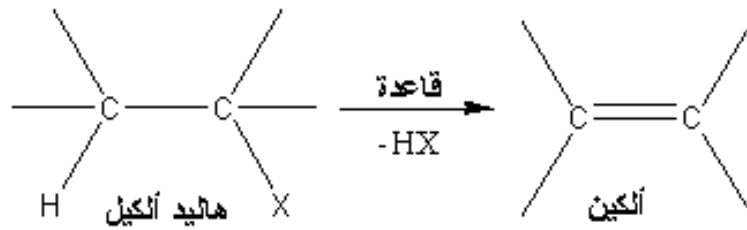

.2

:

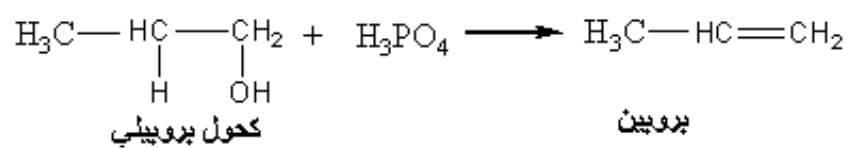
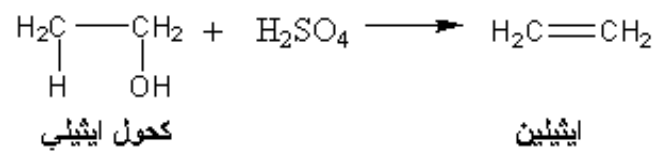

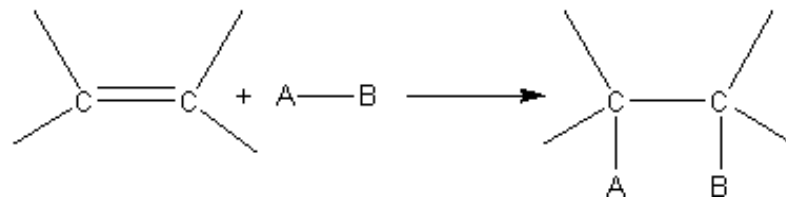
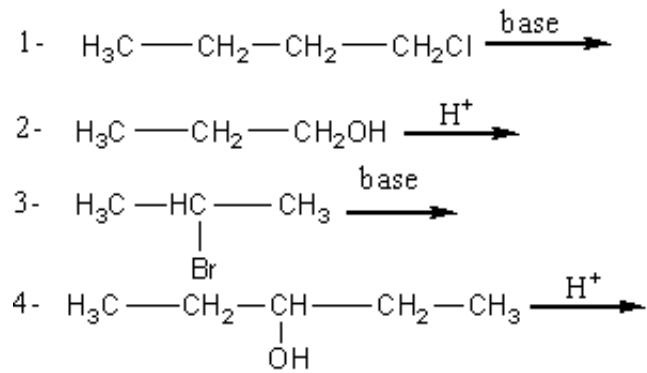

.1

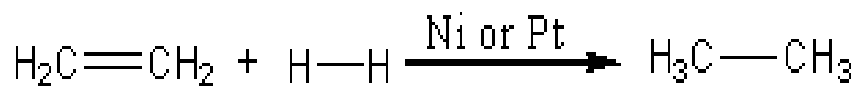

.2



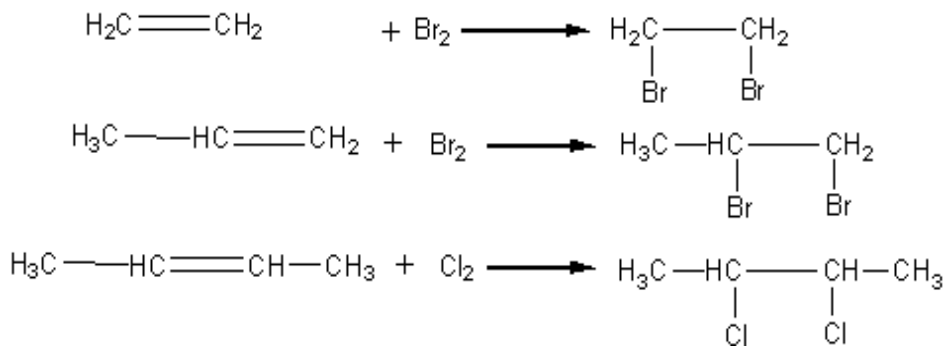

()

.()

:(HBr HCl)

.3

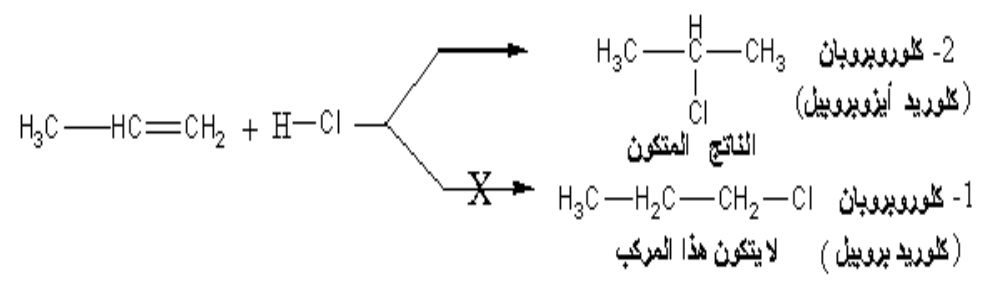
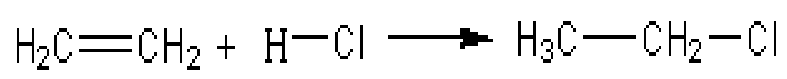

: .4

(H - OH)

(HO-)

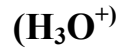

()

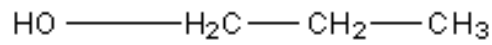
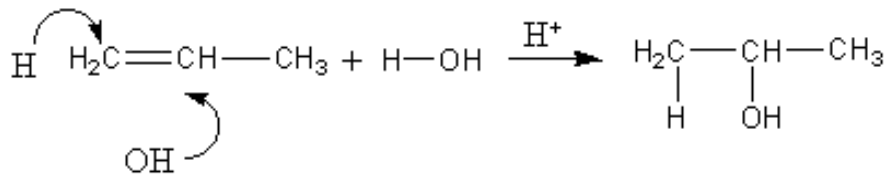
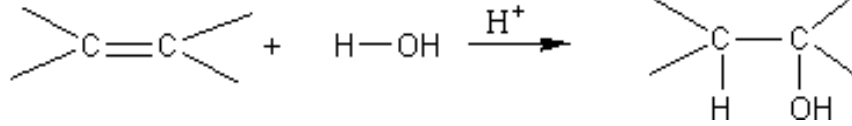

لا يتكون الكحول البروبيئي العادي

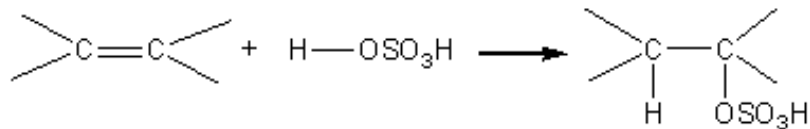
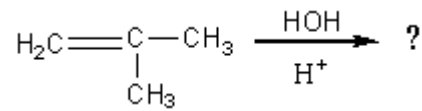

كبريتات الألكايل الهيدروجينية

.5

:

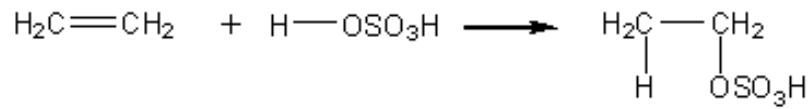

كبريتات الأيثيل الهيدروجينية

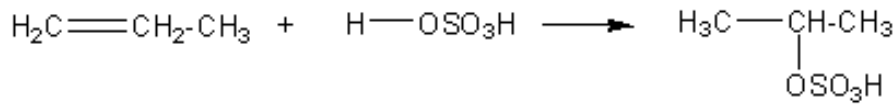

كبريتات الأيزوبروبيل الهيدروجينية

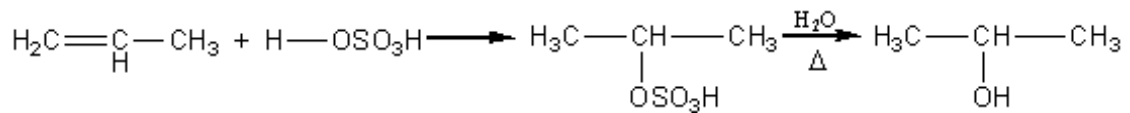

: .6

:

()

(HO-)

:

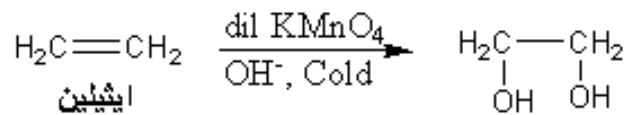

إيثيلين

إيثيلين جليكول

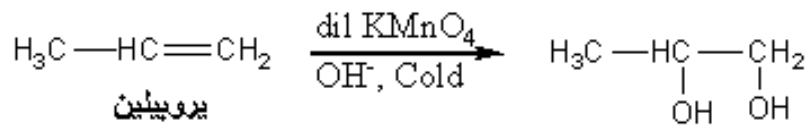

بروبيلين

بروبيلين جليكول

()

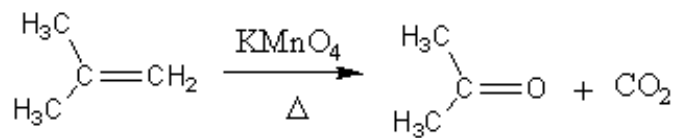
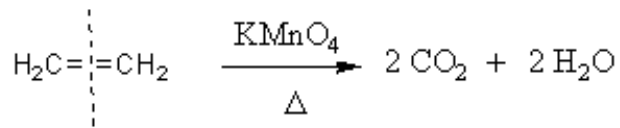
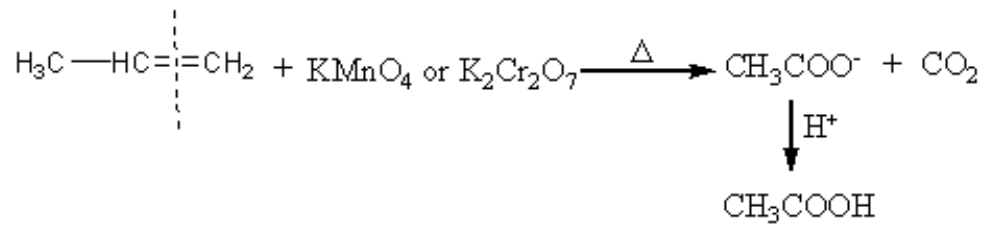

()

(O₃)

Zn

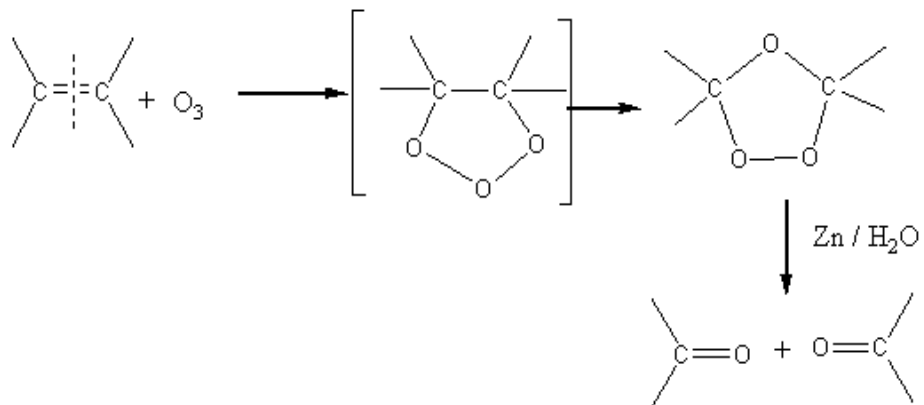

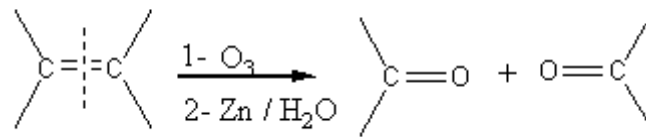

:

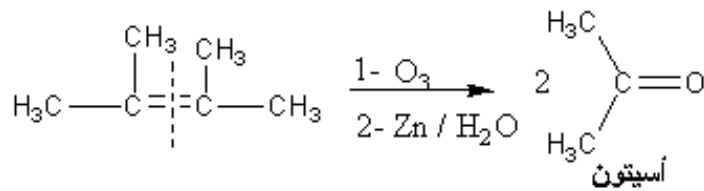
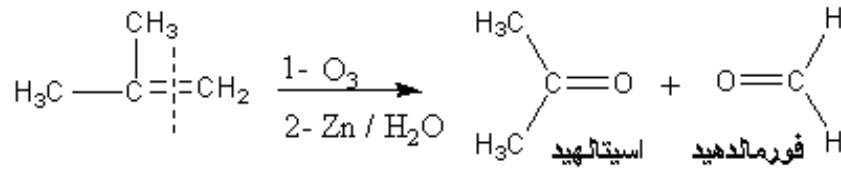
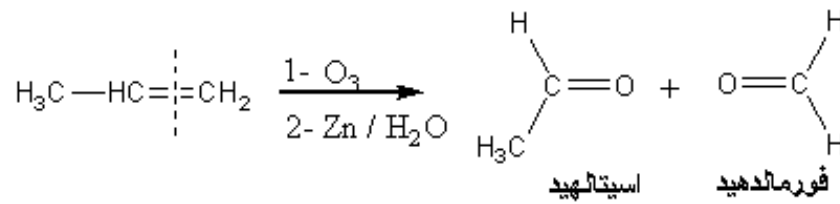

.7

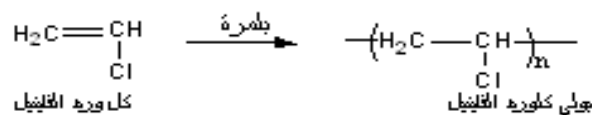
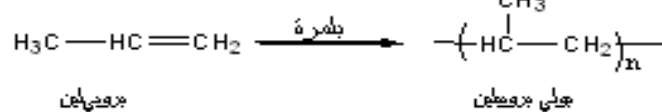
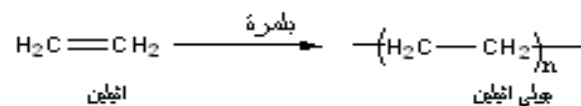

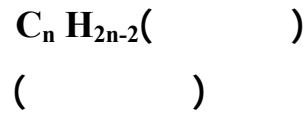

.CnH2n-2

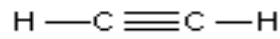

الاسيتيلين
ايثاين

(IUPAC)

() () ()

الاسم الصيغة الجزيئية الصيغة البنائية

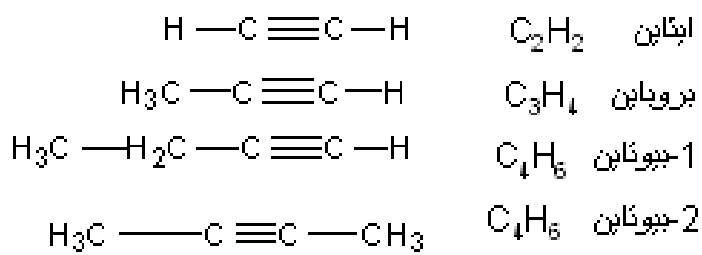

()

:

1

2

3

() ()

4

()

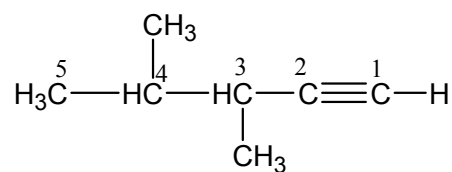

: 5

- 4 3

4 3

- 1 ∴

-1-

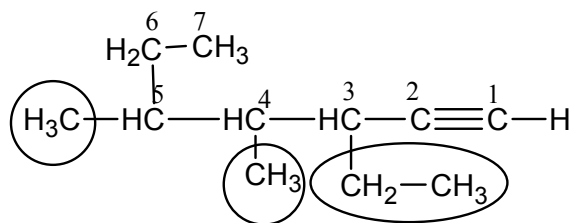

(6)

7

- 1 1

3

5 4

- 1 -

- 4,5 -

- 3

:

:

- 1- $\text{H}_3\text{C}-\text{HC}(\text{Cl})-\text{H}_2\text{C}-\text{C}\equiv\text{C}-\text{H}$
- 2- $\text{H}_3\text{C}-\text{HC}(\text{Br})-\text{HC}(\text{CH}_3)-\text{C}\equiv\text{C}-\text{CH}_2(\text{Br})$
- 3- $\text{HC}\equiv\text{C}-\text{CH}_2-\text{CH}(\text{CH}_3)-\text{CH}_2(\text{Cl})$

)

.(HX

:

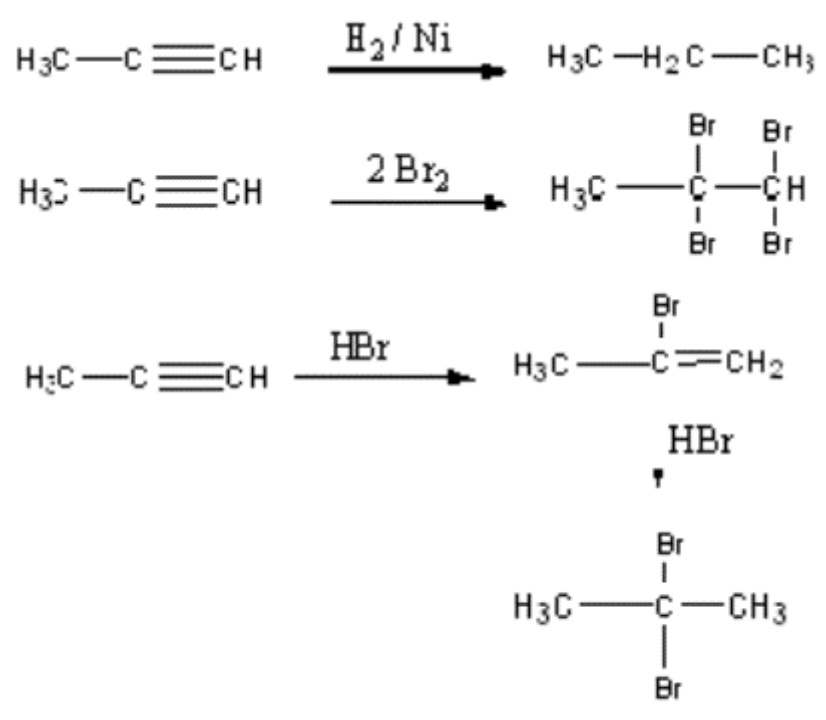

(R-OH)

(-OH)

()

(4 1)

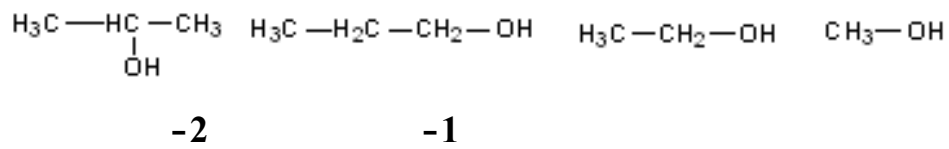

()

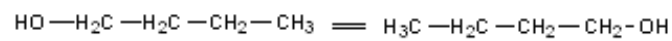

1-جیوٹانول

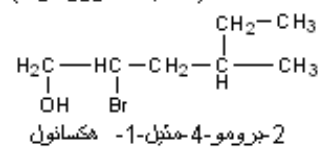
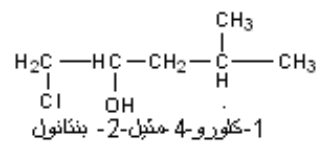
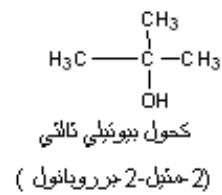
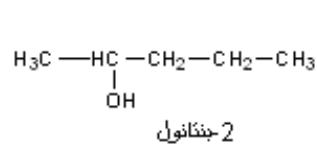

(OH)

.()
. ()
) :
.(

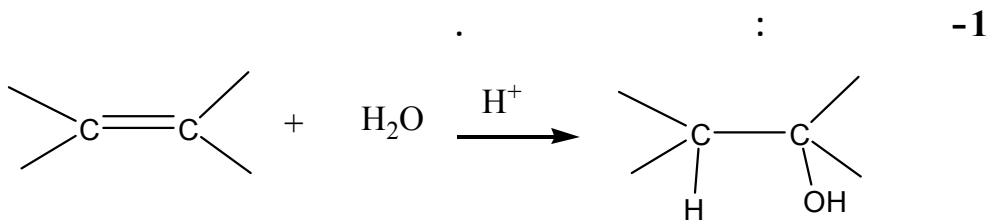
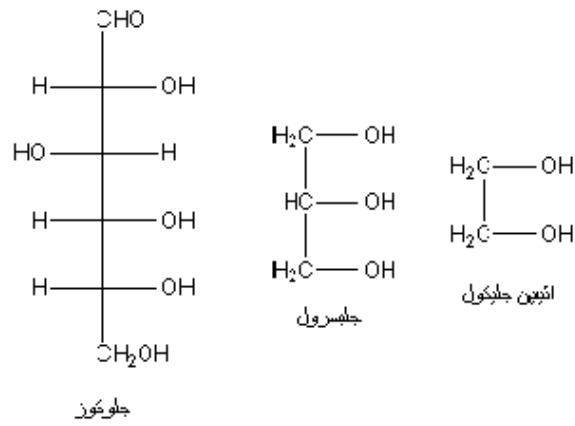

:

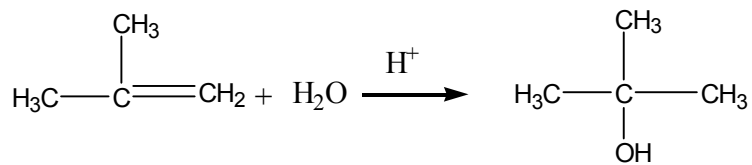
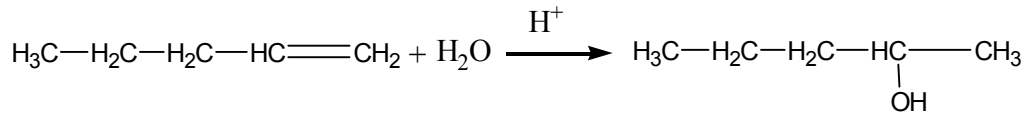
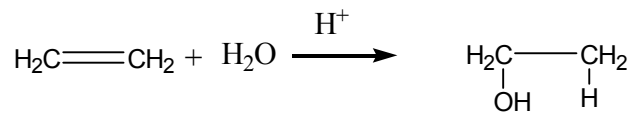

:Dehydration 1

.

:

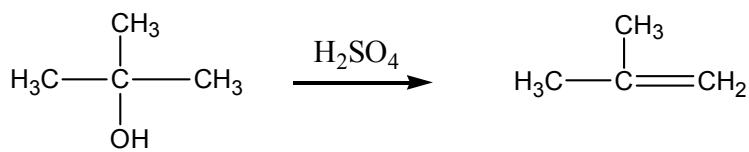
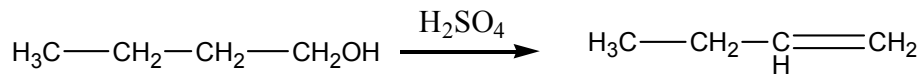
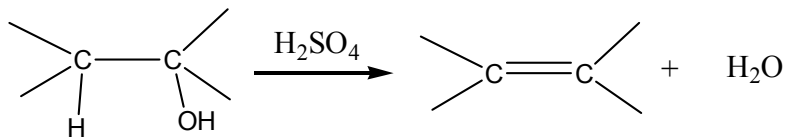

: .2

)

(

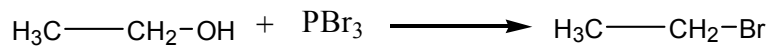
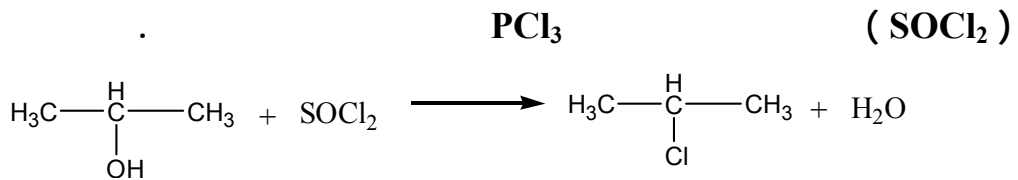
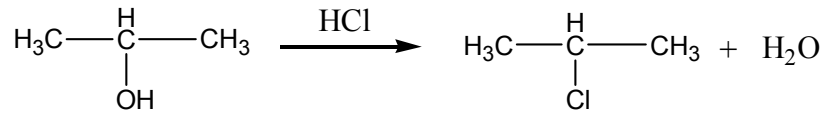
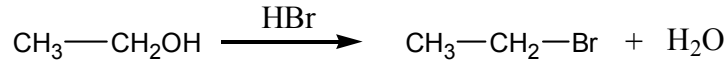
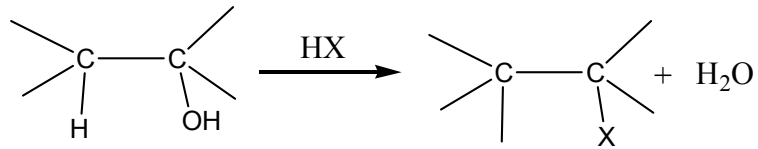

: .3

NaOH

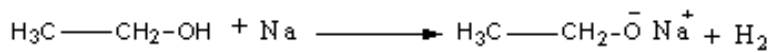

إيثوكسيد الصوديوم

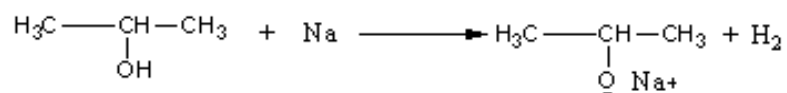

أيزوبروبوكسيد الصوديوم

:

:

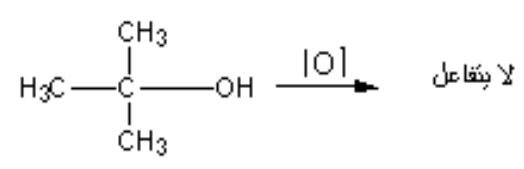
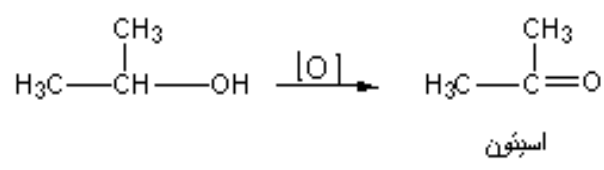
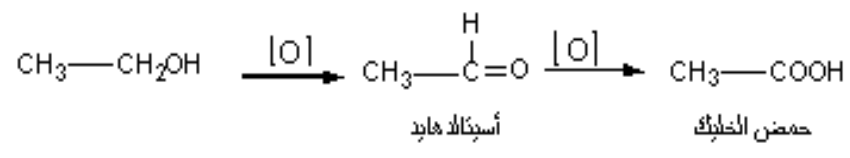

:

:



:

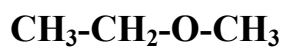
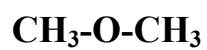

:

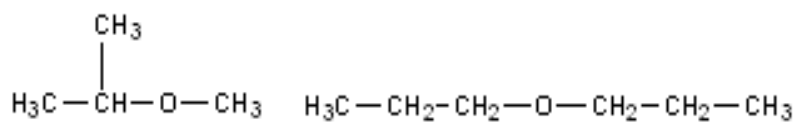

اثير ميتايل ايزوپروپايل

اثير ثنائي پروپايل عادي

: .1

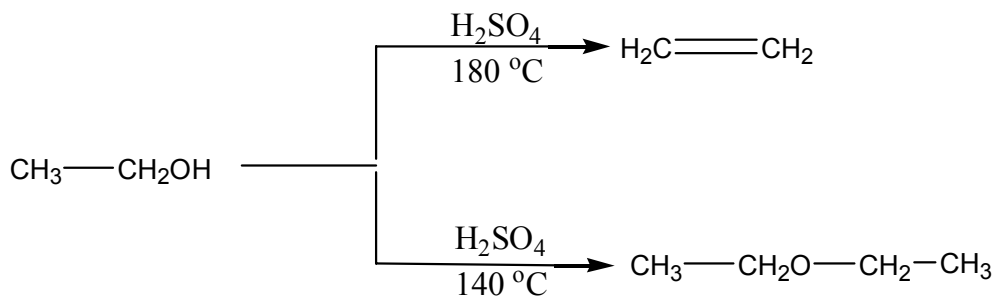

:

.2

()

:

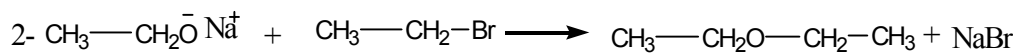
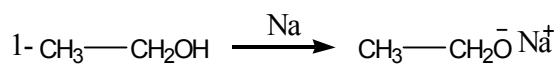

.

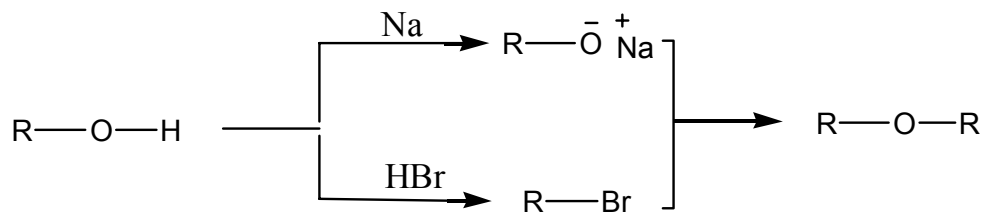

:

:

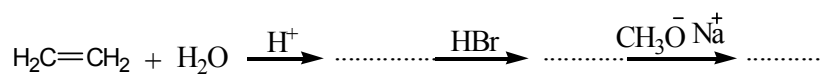

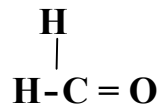
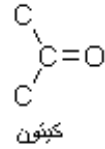
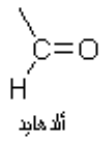

)

.(
:

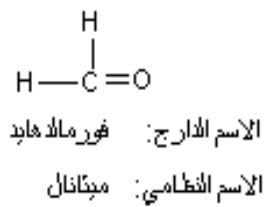
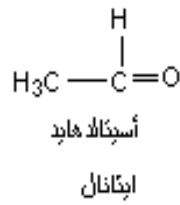
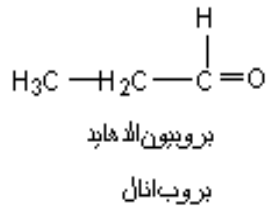

()



(C=O)

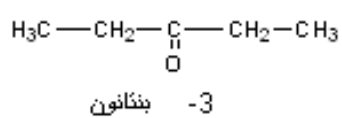
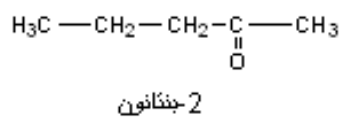
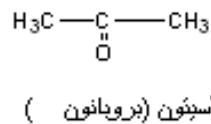
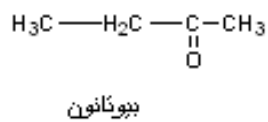

()

)

(

.
:

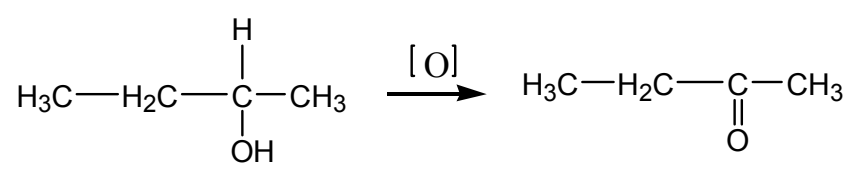
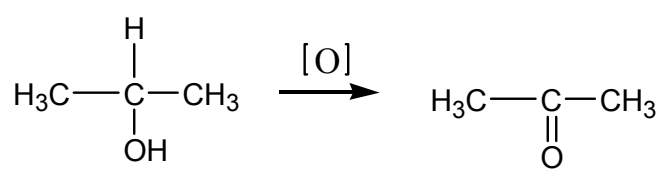
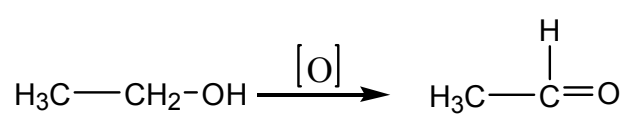
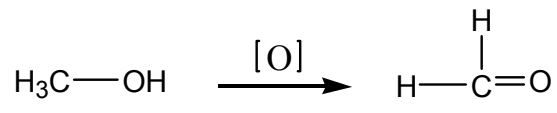

:

.C₅H₁₀O

:

3

4

:

.()

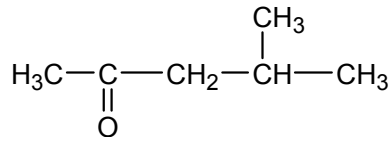

:

:

5

•

•

.()

•

(2)

4

(4)

-2- -

:

:

-2

-2- -4

-3- -2

: .1

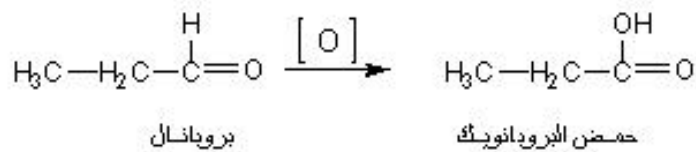

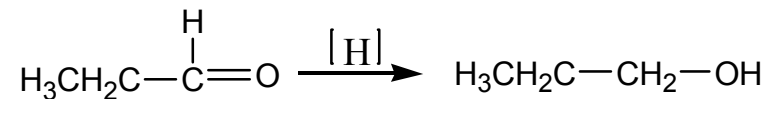
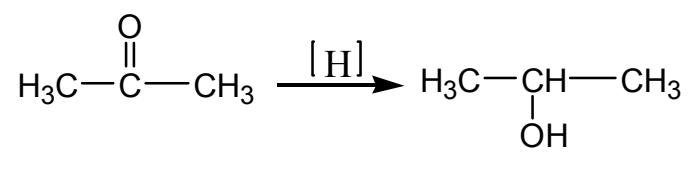
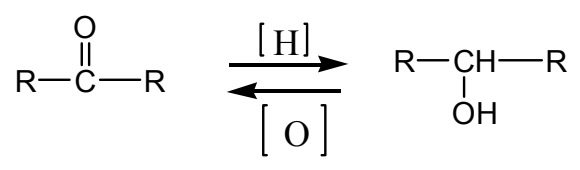
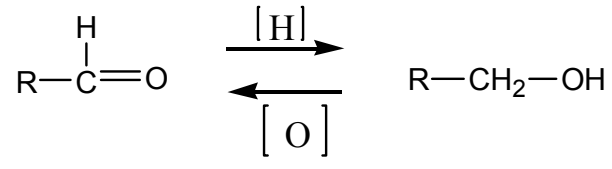

R-COOH :

(C-COOH)

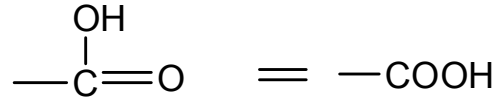

:

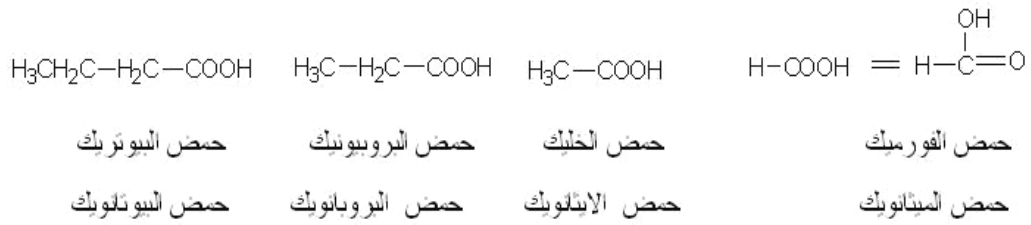

:

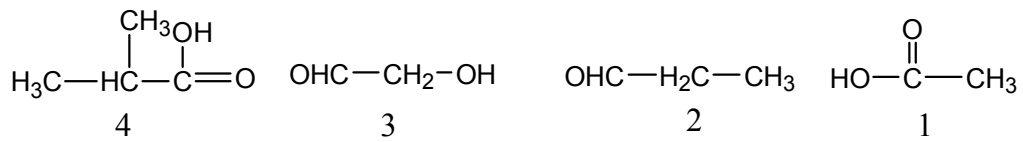

:

3 1

:

4) C₅H₁₀O₂

.(

()
)
 : (IUPAC
 .1
 .2
 .(1) .3
 .4

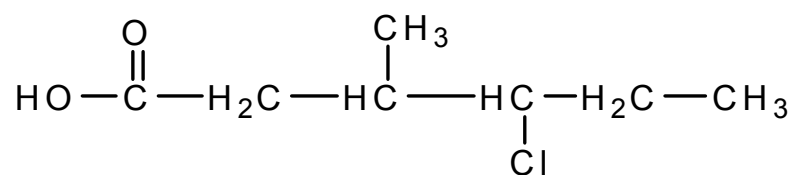

-1

(3)

-2

-3-

-4

(4)

(-COOH)

()

.()

(H-O-)

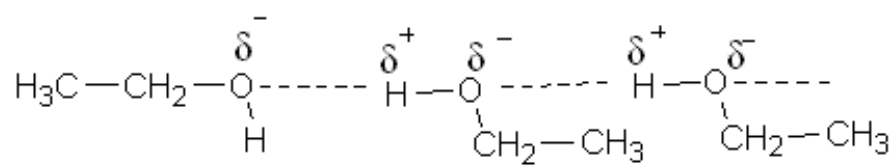

الرابطة الهيدروجينية في الكحولات

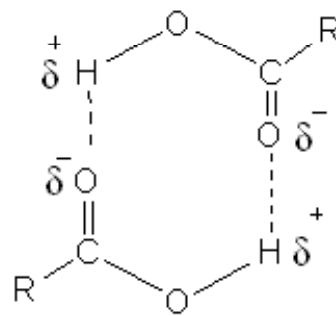

(O)

(N)

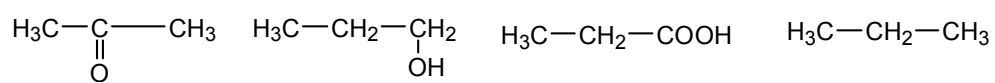

:

.



:

:

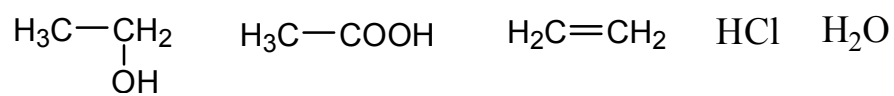

:

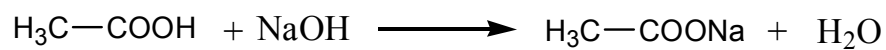

.

:

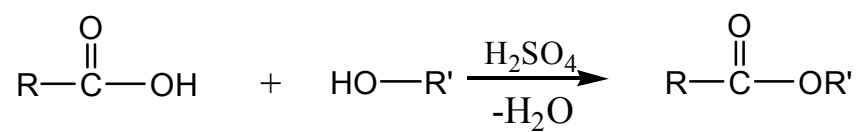

.

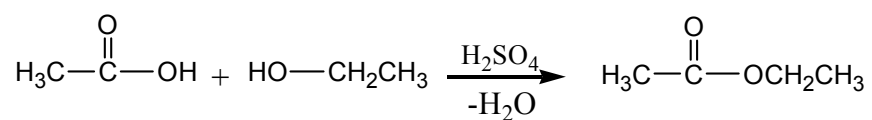

()

.1

.()

.2

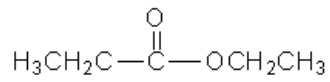

استر بروبانوات الايثيل

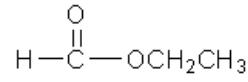

استر فورمات الايثيل

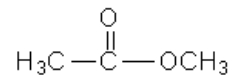

استر خلات الميثيل

:

:

.1

.2 5-4

:()

(KOH NaOH)

.()

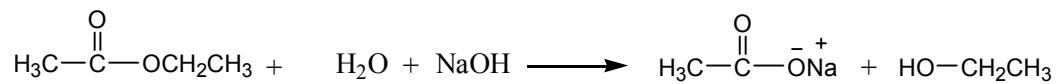
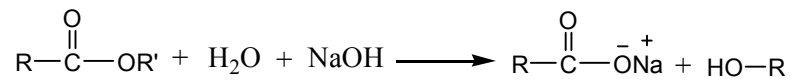

:

()

:

:

