

8BIT DIGITAL CODE SWITCH (with voice operation)

Course Title : Electronic Project Design
Course No : EE3200

Approved By:

Written by,

MR. RAZZAQUAL AHSHAN

Lecturer,
Department of Electrical and
Electronic Engineering,
KUET

MD. IFTEKHAR TANVEER
ROLL – 0203022

3RD Year 2nd Semester,
Session: 2004 - 05

DEPARTMENT OF ELECTRICAL & ELECTRONIC ENGINEERING
KHULNA UNIVERSITY OF ENGINEERING & TECHNOLOGY
KHULNA – 9203, BANGLADESH

Acknowledgements

At first we would like to mention our project guide, **Mr. Razzaqul Ahshan**, Lecturer, Department of Electrical and Electronic Engineering, Khulna University of Engineering and Technology, for his advice, valuable guidance and constant encouragement through out the progress of our work.

Next we would like to gratify all of the teachers of Electrical and Electronic Engineering department for their co-operation.

Authors

OBJECTIVE

The objective of this project is to design and implement a device that will act as a switch which is able to be protected by a password. Only the person who knows the password can be able to turn the switch on. The password can be given by voice and computer.

BRIEF THEORY

About a code switch: A code switch is a device that is able to verify a given password and turn on or off according to it. The password can be given from various sources depending on the purpose and operation of the switch. As for example, it may be a signal from a keypad, a switch array or even from other devices like a digital computer. The given password can be of various forms like binary, BCD, Hexadecimal or alphanumeric code. The operation of the switch also differs according to the purpose to be served.

Magnitude Comparator IC: The hearts of this project are two 4-bit digital magnitude comparators. This IC can compare two 4-bit straight binary and straight BCD data and provide decisions on equalities and inequalities of one data comparing the other one. The pin configuration of the IC is shown in figure – 1. Pin no 10, 12, 13 and 15 are used to provide data A. 1, 9, 11 and 14 are used for data B. Data of greater length can be compared with connecting the IC's in

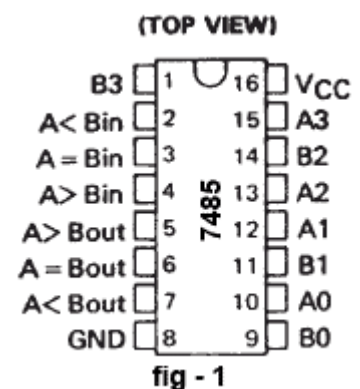

cascade. The $A > B$, $A < B$ and $A = B$ are the outputs of a stage handling more significant bits. The stage handling the least significant bits must have a high – level voltage applied to the $A = B$ input. A complete datasheet for this IC is available in www.alldatasheet.com

INSTRUCTION MANUAL

Overview: This device is an Eight Bit Code Switch. An eight bit binary word is set by an array of switches. Another array of switches will be faced to the user to give a password for verifying. There is a data cord in the device which can be connected to the parallel port of a digital computer. This port can be used by software to provide a password. The operation of this code lock switch is explicitly divided in two parts. A) **Hardware Part** and B) **Software Part**. Each of them is discussed below.

Hardware Part: The 8bit digital code switch can be operated as a standalone device as well as a device that can operate in association with a personal computer. The voice command can be executed by the computer through microphone. It has two arrays of switches in two sides. The side in which a password will be set is named as the **Host Side** while the other one in which the user will give a password to verify is named as the **User Side**. Each side has an array of eight tumbler switches. Each switch has two states – “0” and “1”. A password can be given by various combinations of these switches. There is socket which can be named as **Switch Connection Socket**. This socket is used to operate the load. Its maximum rating is 250V 5A. A descriptive figure of the device is given below.

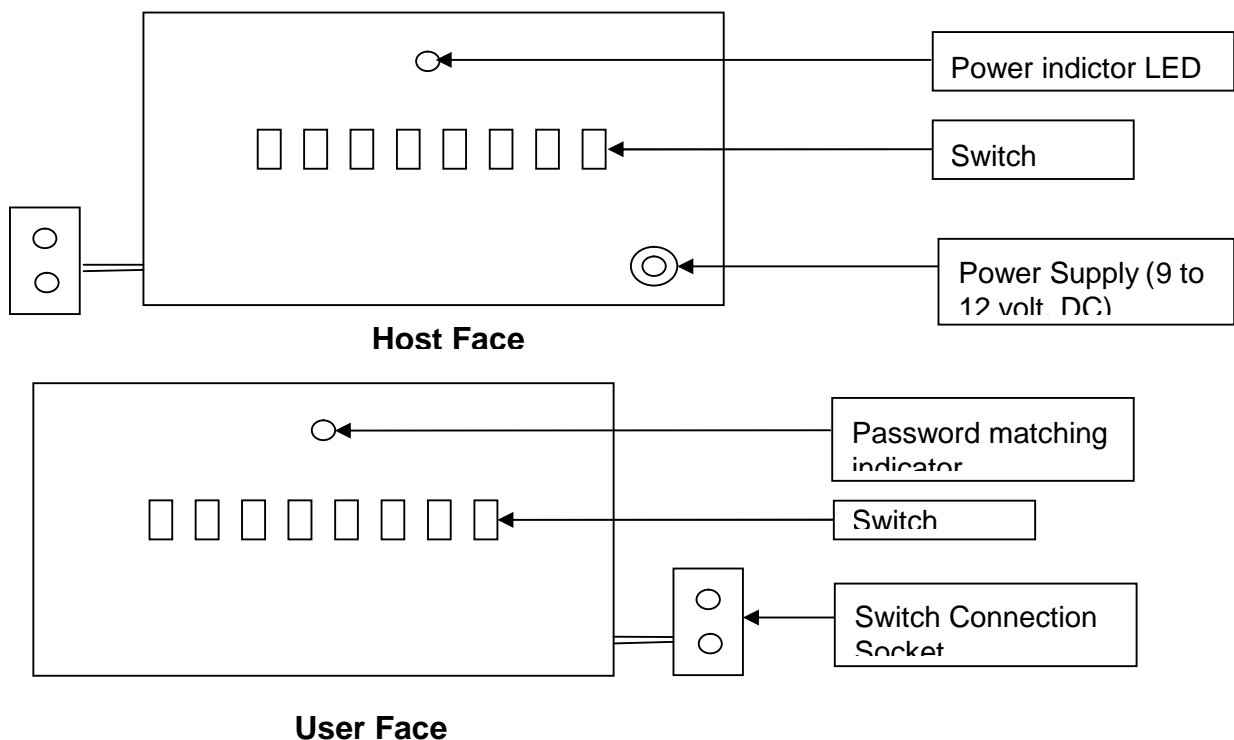
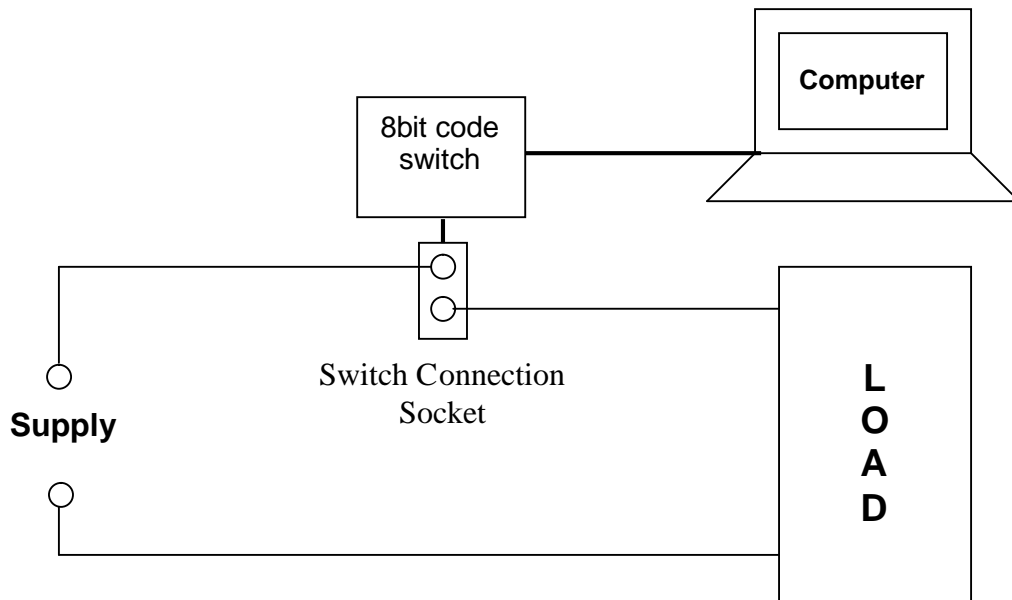
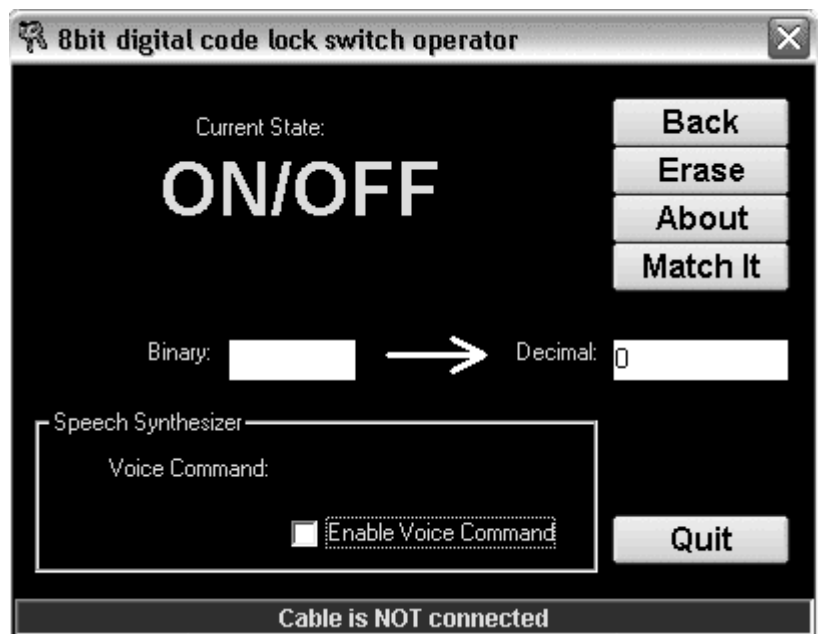

Fig: Two opposite faces of the 8 bit code switch

When using in association with a computer, the data cord of the device is to be connected to the parallel port of the computer. **In this case all the switches of the user side is to be turned in “0” state.** Then the software is used to operate the device. The load connection is given below.



Software Part: The software made to operate the 8bit digital code switch is named as 8bit Digital Code Lock Switch Operator. This is a voice enabled software. That means the commands for the software can be executed by simply loudly speaking the commands in front of a microphone that is connected to the sound card of the PC. The main window of the software is shown in the figure. A brief description of the components of this window is given here:



Current State: It describes the current state of the switch i.e. whether the switch is “on” or “off”.

Binary Field: In the binary field, the password is given in binary form. This field accepts only “0”, “1” and “Backspace”. All the other keystrokes are simply ignored. When entering the password, the user must type it from MSB to LSB.

Decimal Field: Decimal field automatically displays the decimal equivalent of the binary password. User can also manually enter the decimal equivalent of the password in this field.

Back: When this button is pressed, the last bit entered in the binary field will be erased.

Erase: This button clears the binary field as well as the decimal field.

About: The about button shows the about dialog box which shows some information on the authors of the software.

Match It: When the “Match It” button is pressed, the software will send necessary information to the parallel port and drives the device.

Quit: This button terminates the software.

Speech Synthesizer: There is a speech synthesizer built into the software. When the “Enable Voice Command” is checked, the speech synthesizer is ready to use. Now if anything is spoken to the microphone, the synthesizer automatically tries to match the words spoken with “Zero”, “One”, “Back”, “Erase”, “About”, “Match It”, and “Quit”. When a suitable match is found, the software performs the necessary tasks for that word.

Status Bar: The status bar at the bottom of the window gives the current state of the data cable. If the data cable is connected to the parallel port, it shows, *"Cable is connected: OK"*. Else it shows, *"Cable is NOT connected"*

DESIGN PROCEDURE

Circuit Diagram:

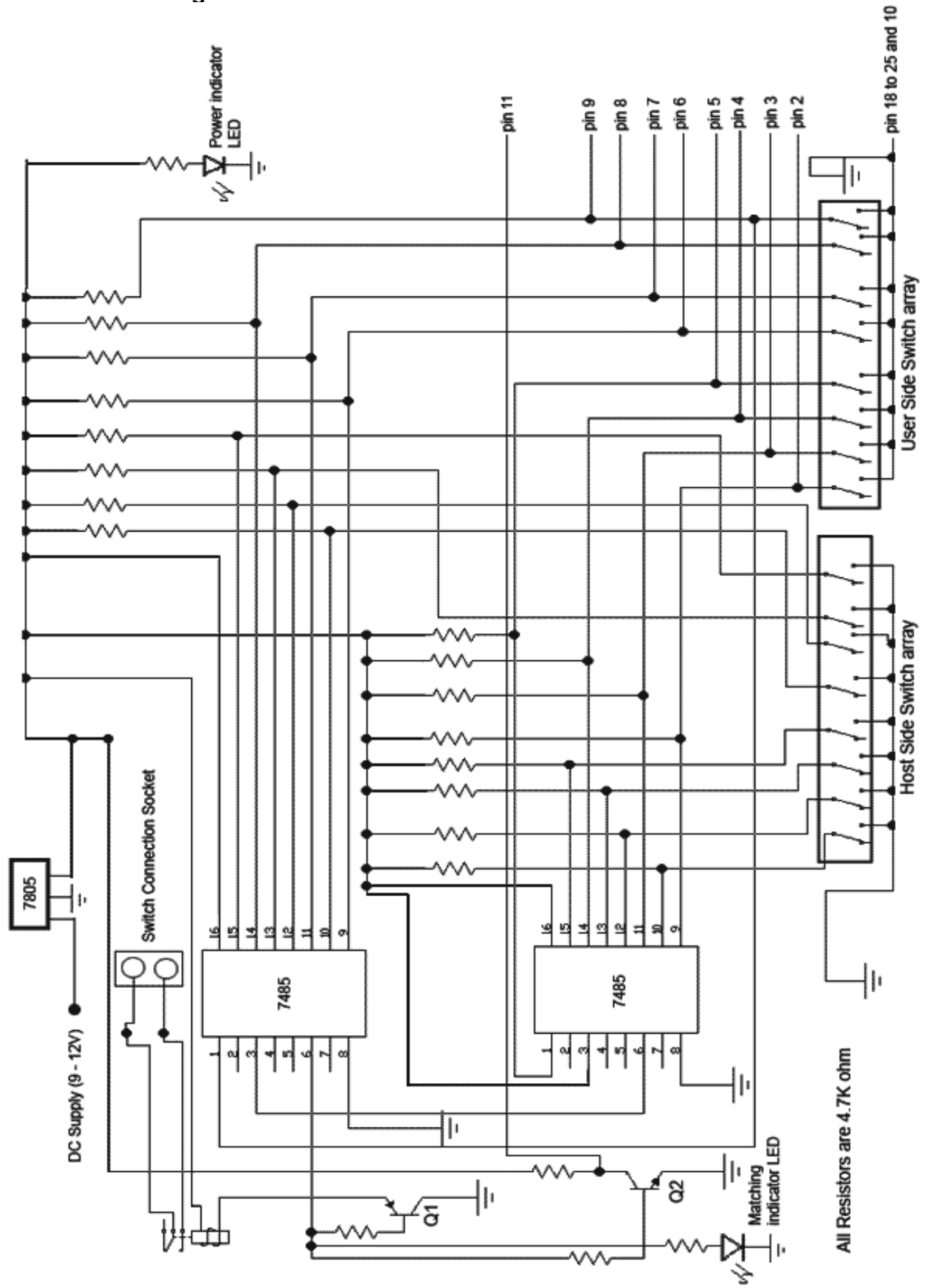

All Resistors are 4.7K ohm

Parts List:

- 1) Magnitude Comparator IC (7485) – 2 pieces
- 2) Parallel Port Data Cord
- 3) Transistors (Q1 = 2SA1015, Q2 = BC548)
- 4) Regulator IC (7805)
- 5) Relay (DC 6V, AC 250V 5Amp)
- 6) Resistors (4.7K ohm) – 20 pieces
- 7) Tumbler Switches – 16 pieces
- 8) Light Emitting Diode (LED) – green 1 piece, red 1 piece
- 9) Vero board, wire, solder etc.

Circuit Operation: The main components of the circuit are two 4bit magnitude comparators. Input impedances of these IC's are quite high. When the switches and the resistors are connected to the data pins as shown in the circuit diagram, it is possible to set the pin at "high" or "low" state by simply turning the switch "off" and "on" respectively. When a switch is on, the pin of the IC corresponding to that switch will get a "low" signal from the ground. When it is off, no current will flow through the resistor (As the input impedance of the IC is also high) and consequently there is no voltage drop in the resistor. So the input pin gets "high" signal.

Now, this resistor and switch combination is used in all the sixteen input pins of the comparator IC. All the 8 pins for data A are connected to the host side switch array and pins for data B are connected to the user side switch array. The pin no 3 of the IC containing the least significant bit is connected to Vcc. The output pin of this IC (pin 6, for A = B) is connected to pin no 3 of the other IC. Pin 6 of this IC is used to drive the transistor Q1 which ultimately drives the relay.

When the user side switching combination exactly matches with the host side combination, the A = B output (pin 6) becomes high and makes the relay turn on. As well as it will light up the "Matching Indicator LED". The job of the other LED is to show the presence of power.

Communication between PC and Circuit: The circuit communicates with the computer through the parallel port of the computer. A DB-25 connector is used for this purpose. Pin configuration for female type connector is given here. Pins 18 to 25 are ground. Pin no 2 to 9 is known as the **data line**. Pin 10 to 13 and 15 is known as **status line**. Others are known as the **control line**. The data line is used to send the bits from the

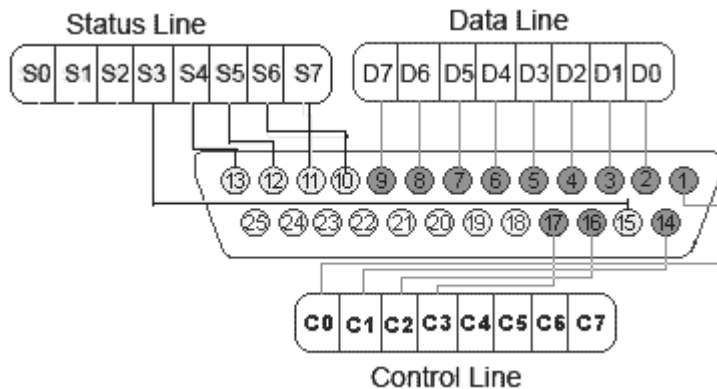

parallel port to the circuit. These pins are used in parallel with the switches of the user side to send the data. Here, “Data 0” is the LSB. All the pins are connected to the switches according to their weights. When using the computer, all the switches of the

user side must remain in “off” state.

One thing is to mention here that, when a switch is in state “1”, it sends low voltage to the comparator IC, but when the port pin is in state “1”, it sends high voltage. So, to match with the switch combination, the data from the parallel port must be 1’s complement of the data we wanted to send. For example, if the password be 11101011, we must send 00010100 to the data line. This can be done easily by performing XOR operation to the data with 11111111 (11101011 XOR 11111111 = 00010100). This process is done in the software. Before sending to the data line, a data was XORed by 255.

For getting feedback information from the circuit we used the status line. In general, pin 11 (Status-7, 127) is inverted, i.e. it is “ON” when nothing is connected to the port. So, in this case the status line shows 127. Pin 10

Pin No (DB25)	Signal name	Direction	Register - bit	Inverted
1	nStrobe	Out	Control-0	Yes
2	Data0	In/Out	Data-0	No
3	Data1	In/Out	Data-1	No
4	Data2	In/Out	Data-2	No
5	Data3	In/Out	Data-3	No
6	Data4	In/Out	Data-4	No
7	Data5	In/Out	Data-5	No
8	Data6	In/Out	Data-6	No
9	Data7	In/Out	Data-7	No
10	nAck	In	Status-6	No
11	Busy	In	Status-7	Yes
12	Paper-Out	In	Status-5	No
13	Select	In	Status-4	No
14	Linefeed	Out	Control-1	Yes
15	nError	In	Status-3	No
16	nInitialize	Out	Control-2	No
17	nSelect-Printer	Out	Control-3	Yes

(Status-6, 64) is always grounded into the circuit. This indicates whether the cable is inserted or not. When the cable is inserted to the parallel port, this pin will be grounded and the software will read the value of status line as $127 - 64 = 63$. For detecting the matching of passwords, pin no 11 is used through a transistor Q2. When the passwords match and the final comparator IC gives its output as “high”, the transistor (Q2) goes to the saturation region, shorting the pin to the ground. This makes the value of status line as $127 - 64 - 127 = -64$ which is in fact 191 ($-64 + 255$). So, we can summarize the decisions from the data of status line as follows.

Data (Decimal Value)	Decisions
63	Cable Inserted, Password Didn't Match
191	Cable Inserted, Password Matched
127	Cable is NOT inserted

Software for 8bit Digital Code Switch: The software is made by Visual Basic 6. The installer is made by Innosetup. Innosetup is a copyrighted to Jordan Russel (www.innosetup.com) and Visual Basic is copyrighted to Microsoft Corporation (www.microsoft.net). A speech recognition engine is used in this project which is available in the web page of Microsoft Corporation. Under Windows XP platform it is not possible to access any hardware in application mode. One must need to enter into the kernel mode to access to any port. This job can be made easier by using a dll named inpout32.dll (<http://www.logix4u.net>). The outstanding feature of Inpout32.dll is it can work with all the windows versions without any modification in user code or the DLL itself. The Dll will check the operating system version when functions are called, and if the operating system is WIN9X, the DLL will use `_inp()` and `_outp` functions for reading/writing the parallel port. On the other hand, if the operating system is WIN NT, 2000 or XP, it will install a kernel mode driver and talk to parallel port through that driver. The user code will not be aware of the OS version on which it is running. This DLL can be used in WIN NT clone operating systems as if it is WIN9X. From Visual Basic, the function Out32 is used to send the data to the data register. The address of data register is 0x378 for LPT1. A complete list is as follows:

Register	LPT1	LPT2
data register (base address + 0)	0x378(888)	0x278(632)
Status register (base address + 1)	0x379(889)	0x279(633)
control register (base address + 2)	0x37a(890)	0x27a(634)

The detailed theory and principles of Visual Basic, Speech Recognition Engine, Port Programming and the source code of the software are beyond the scope of this report and are not discussed here.

SPECIFICATIONS

- Input Supply: 9 to 12 volt, DC
- Power Consumption: 557mW (Appx.) in 9 volt
- Minimum Requirements for PC:
 1. Pentium 500Mhz processor
 2. Windows 9x or XP platform
 3. Parallel port (LPT1)
 4. Sound Card

DISCUSSION

The 8bit Digital Code Switch we constructed is able to match only 256 combinations. It is possible to manually try 256 combinations and find the password. So this is not a strong password system. But the number of bits can be increased by cascading more comparator IC's. 4 IC's will result in 16 bits for which there will be 65536 combinations. However, the parallel loading method, which is used in this project for sending data from PC to the circuit, is not appropriate in the case where the number of bits is greater than 8. In that case, Serial port should be used in association with a shift register. Moreover, a decimal keypad should be used for entering the passwords and setting them since bitwise input of 16 or greater bit binary word is a tedious work.

REFERENCE

- *Monthly Electronics For You* www.efymag.com
- Gordon McComb, "*The Robot Builders Bonanza*"
- A. K. Maini, "*Electronics Projects for Beginners*", Pustak Mahal, J-3/16, Daryaganj, New Delhi.
- www.logix4u.net
- www.planet-source-code.com
- www.microsoft.net
- www.alldatasheet.com