

Section 3

BODY INTERIOR (HARD)

CEILING MOLDING

Refer to Figure 3-1.

1. Using a block and pry bar, pry ceiling molding away from ceiling.
2. Cut new ceiling molding to correct length.
3. Nail or staple new molding strip in place.

CEILING PANEL REPLACEMENT

Refer to Figure 3-1.

1. Remove ceiling molding where needed.
2. If ceiling is damaged in cabinet area, remove overhead cabinets. (See cabinet removal in this section.) In some cases cabinet need not be removed, and replacement panel instead of extending for full vehicle width can be stopped at the cabinet. Molding is used to cover joint between cabinet and ceiling panel.
3. Remove air conditioner, roof mounted antenna, and vent molding where applicable. See appropriate section in this manual.
4. If cabinets are not removed, remove plastic molding on top edges of cabinet.
5. With a utility knife, cut the damaged ceiling panels as close as possible to cabinets.
6. Install 2" x 2" board between roof rafters and cabinet top to which new ceiling tile is to be fastened.
7. In case some foam insulation falls out, replace with fiberglass insulation.
8. Cut new ceiling panel for a snug fit.
9. Position ceiling panel.
10. Staple edges of panel. Nail to secure center sections.
11. Install plastic 1/4 round molding around ceiling and cabinet joint with nails or staples.
12. Reinstall molding around air conditioner, antenna, vents, etc.

NOTE: On Trans-Van and Tran-Star models ceiling must be replaced in prefabricated sections. Patching and splicing is not recommended.

OVERHEAD CABINET REMOVAL

Refer to Figure 3-2.

1. Turn off electrical circuits.
2. Remove any light, vent or speaker fixture from cabinet.
3. Disconnect all wires.
4. Raise floor of cabinets by prying with screwdriver.
5. Remove screws holding cabinet to wall and ceiling.
6. Remove cabinet.
7. Install new cabinet in reverse order to steps listed above.

OVERHEAD CABINET DOOR REPLACEMENT

Refer to Figure 3-2.

1. Remove screws from door hinge.
2. Remove door.
3. Remove screws holding door latch.
4. Remove hinges.
5. Using old door as template, mark hinge and door handle locations on new door.
6. Install door handle and hinges on new door.
7. Line up door on cabinet and screw hinges in place.

ROLLTOP CABINET DOOR REPLACEMENT

Refer to Figure 3-2.

1. Remove screws from both door tracks.
2. Remove track and rolltop door.
3. Replace by reversing above procedure.

LOWER CABINET REPLACEMENT

Refer to Figure 3-3.

Removal

1. Remove doors and drawers. Doors are removed by removing hinges.

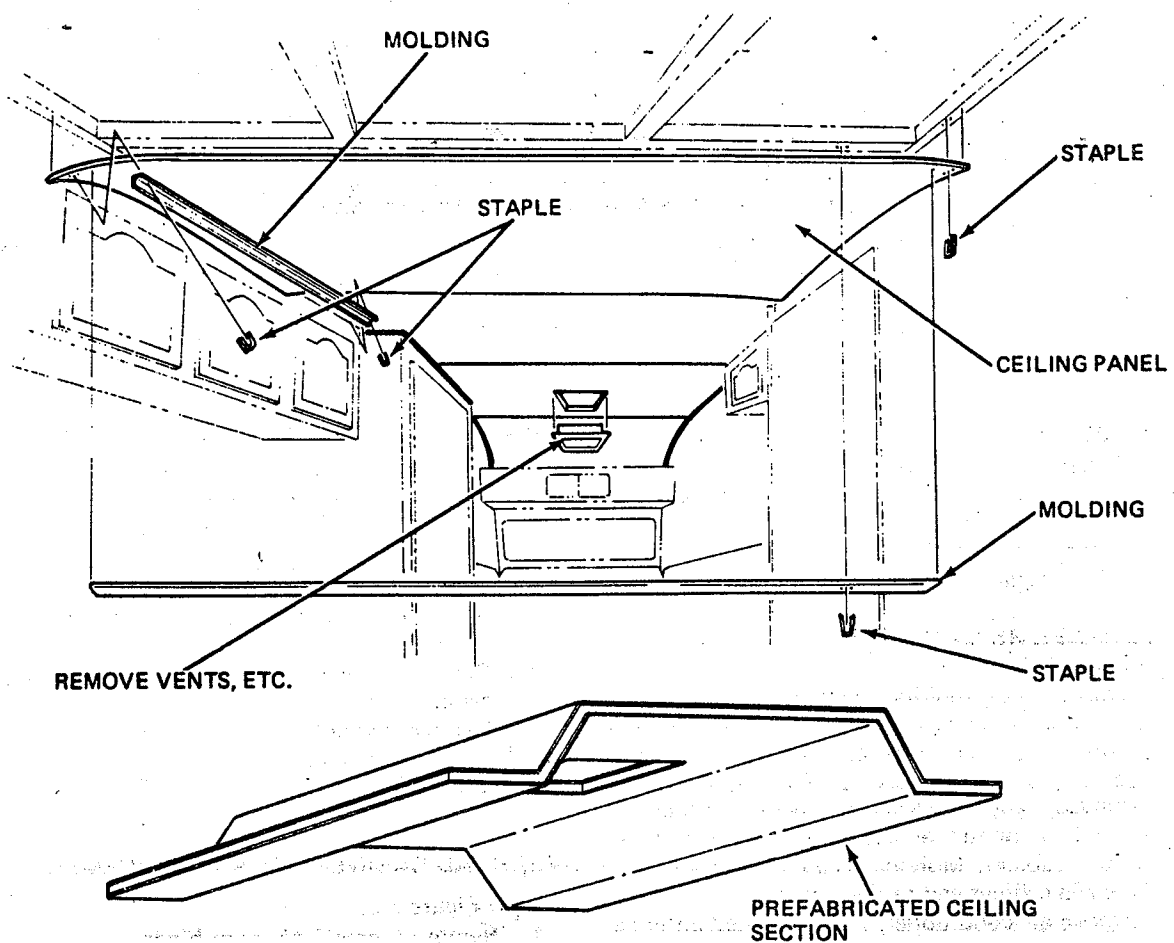

FIGURE 3-1 Ceiling panel molding & panel

2. Remove gas range. Refer to gas range removal in Appliance Section.
3. Remove faucets and plumbing. Refer to Plumbing Section.
4. Remove splashboard and countertop. Refer to Countertop and Kitchen Backsplash Board replacement in this section.
5. Remove screws from cabinet floor, walls, and remove slides of drawer track at back.
6. Remove lower cabinet.
7. Remove drawer tracks.
8. If required, use lower cabinet face as a template for new cabinet front.

Replacement

1. Install drawer tracks on new cabinet front.
2. Place cabinet in position and screw in place.
3. Attach rear drawer slides to wall.
4. Slide drawers into position.

IMPORTANT: Drawer must be pushed in flush with cabinet and held in place while screws are installed to mount drawer guide track spacer.

5. Reinstall cabinet top, backsplash and gas range and plumbing.

CABINET DRAWER – ONE PIECE PLASTIC

Refer to Figure 3-4.

Removal

1. Lift drawer and pull out.
2. Replace with new drawer.

CABINET DRAWER FRONT REPLACEMENT

Refer to Figure 3-4.

1. Remove old drawer.
2. Remove handle.

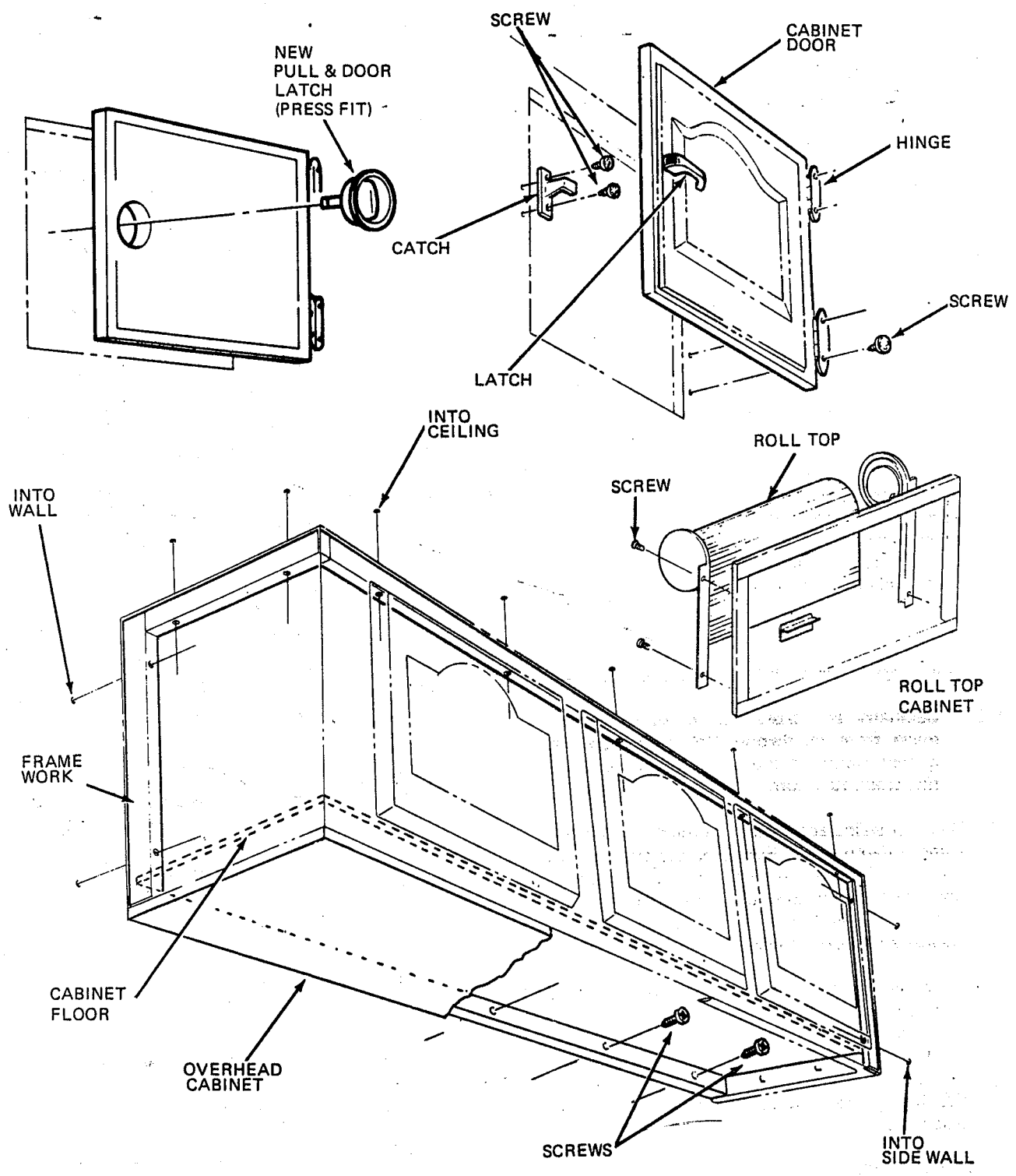

FIGURE 3-2 Overhead cabinet and door

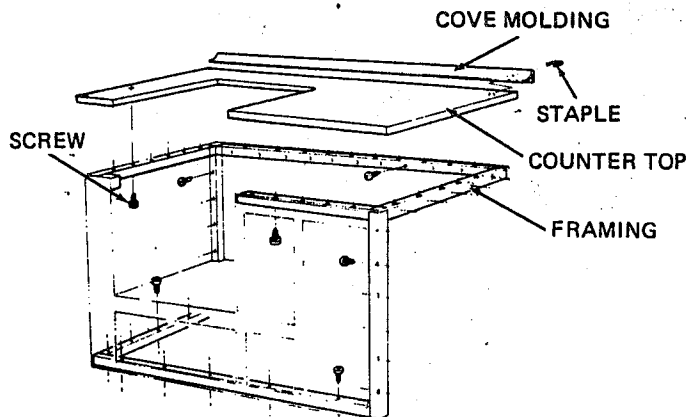

FIGURE 3-3 Lower cabinet

3. Pry off old door front.
4. Apply contact cement to drawer front and new plastic drawer front.
5. Press together and bond.
6. Replace new drawer.
7. Install handle on new drawer front.

For cabinet hinges, latches and moldings see Figure 3-5.

NOTE: Cabinetry and table tops in some units are made from Hardwood Oak with hand lacquered finish. It must be maintained as all fine wood furniture.

- * Wipe up stains and water as quickly as possible, using a damp cloth. For complete cleaning, use Murphy's Oil Soap or Flax Soap as directed on container. These products are sold at most hardware stores. DO NOT use a detergent cleaner such as Mr. Clean or Fantastik.
- * To polish, use any popular brand of household furniture polish. To wax, use only paste waxes such as Original Simonize, Johnson's, or Butcher's. Never use a combination cleaner-wax.
- * DO NOT place hot cookware directly on the wood top.

Keep tables waxed as they sustain heavy usage.

Minor scrapes and scratches can easily be repaired by lightly sanding with No. 600 fine grit sandpaper

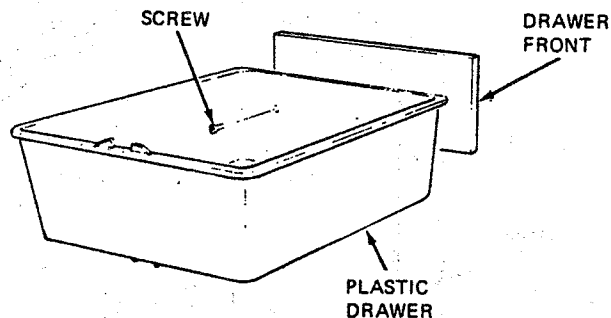
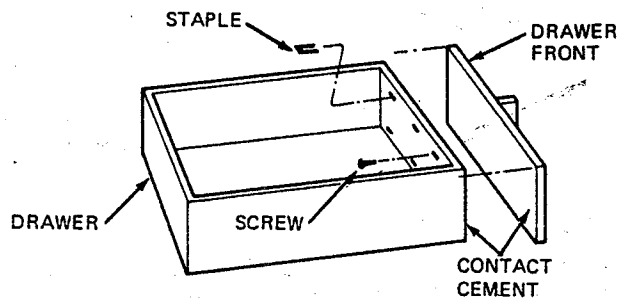
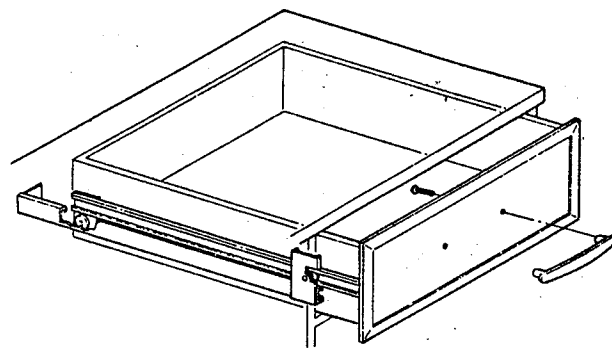

FIGURE 3-4 Cabinet drawer front

and spraying with clear lacquer (available in any paint or hardware store).

HIGH BACK BUCKET SEAT REPLACEMENT

Refer to Figure 3-6.

1. Slide seat to rear and remove 2 bolts attaching seat to slide.
2. Move seat forward and remove 2 bolts attaching seat to slide.
3. Lift off seat.

To replace, reverse procedure.

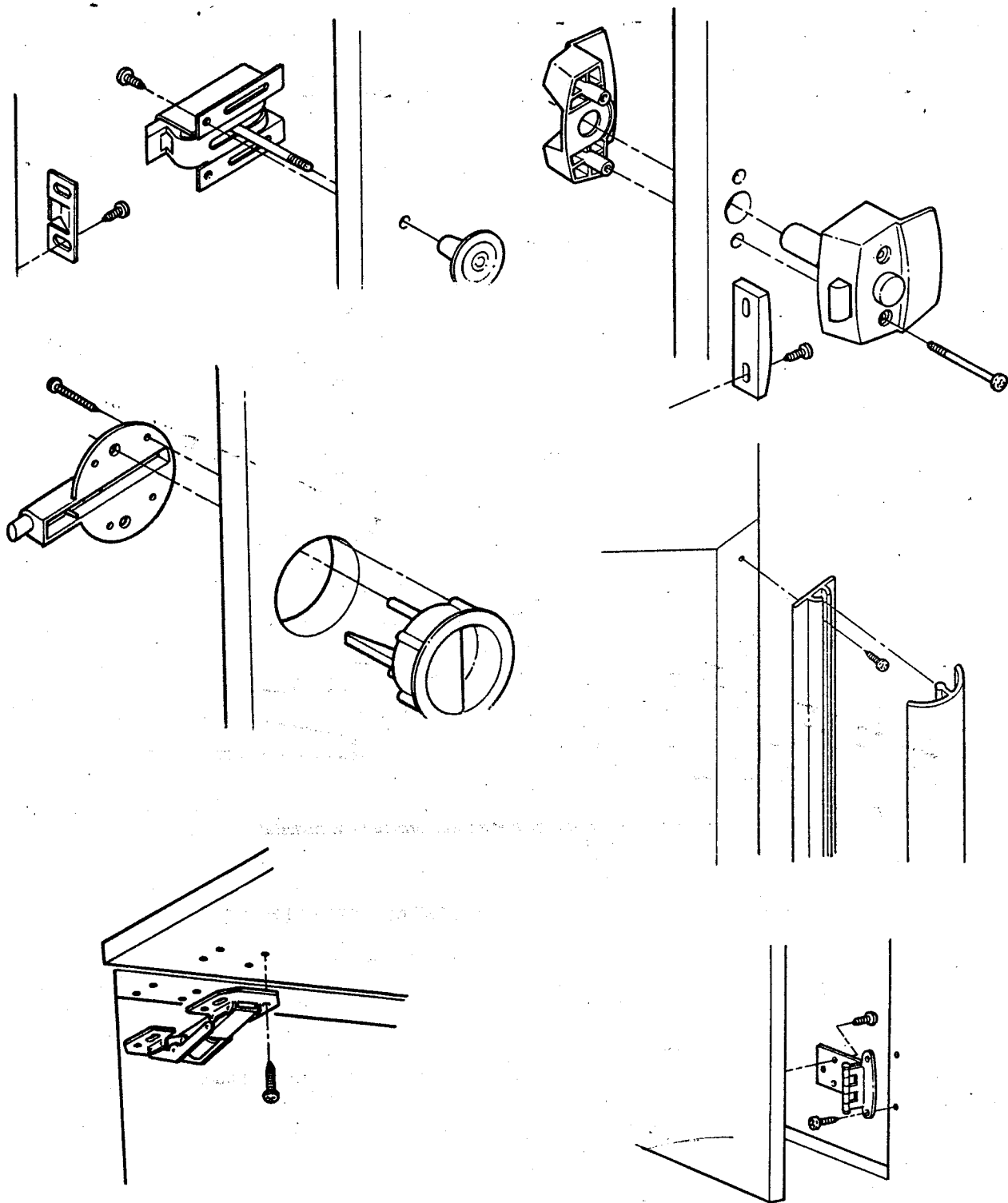

FIGURE 3-5 Cabinet hinges, moldings and latches

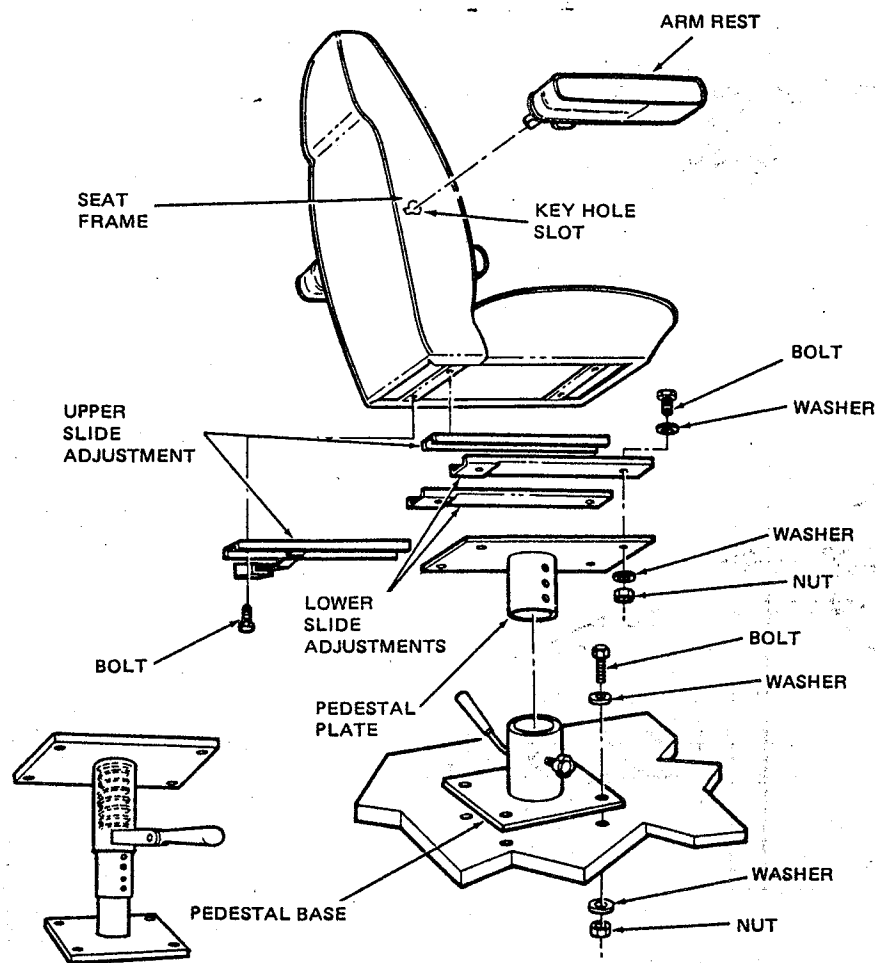

FIGURE 3-6 High back bucket seat, arm rest and pedestal

ARM REST INSTALLATION

Refer to Figure 3-6.

1. Rotate arm rest back toward seat back until lug on arm rest lines up with slot in mounting plate.
2. Remove arm rest by pulling out from seat back.
3. Install new arm rest by reversing removal procedure.

PEDESTAL REPLACEMENT

Refer to Figure 3-6.

1. Remove seat.
2. Remove bolts, nuts and washers holding pedestal base to floor of motor home. (Access to bolts is under motor home.)
3. Install new pedestal.
4. Install seat to new pedestal plate.

SEAT PEDESTAL SLIDE REPLACEMENT

Refer to Figure 3-6.

1. Remove seat from pedestal plate.
2. Remove nuts and washers holding slide adjustments to bottom of seat.
3. Reinstall new slide adjustments making sure right and left slides are on proper side.

45° SEAT PEDESTAL

Refer to Figure 3-7.

Removal

1. To remove seat from pedestal remove 4 bolts from slide mechanism and remove seat.
2. To remove pedestal remove bolts holding pedestal to floor.

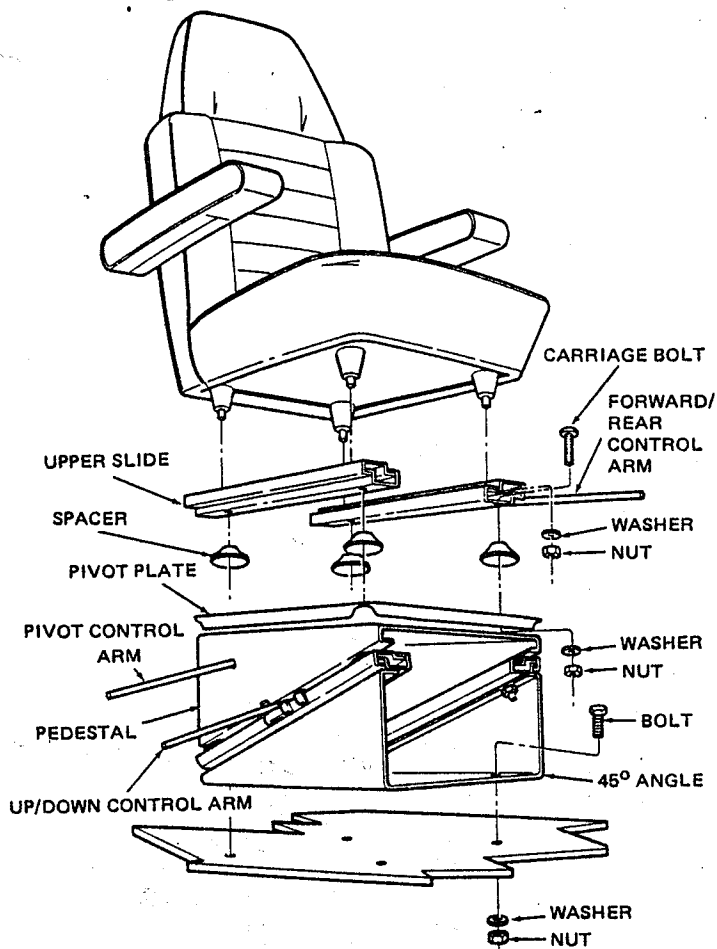

FIGURE 3-7 45 degree seat pedestal

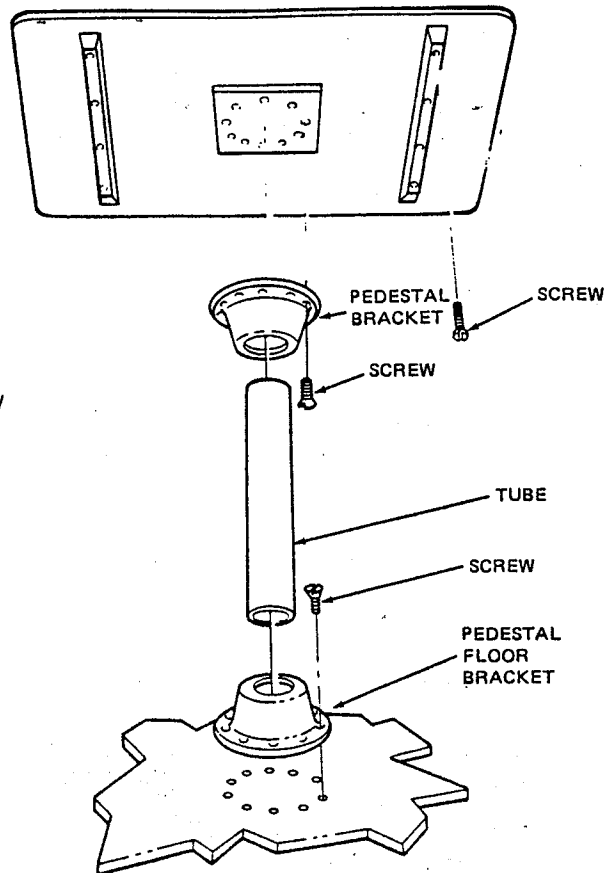

FIGURE 3-8 Pedestal table (all models)

PEDESTAL TABLE TOP REPLACEMENT

Refer to Figure 3-8.

PEDESTAL TABLE FLOOR BRACKET REPLACEMENT

Refer to Figure 3-8.

1. Remove screws holding floor bracket.
2. Install new bracket.

FOLD OUT TABLE REPLACEMENT

Refer to Figure 3-9.

Removal

1. Place table in upright position.
2. Remove screws located on back mounting plate.
3. Remove table.
4. Reverse order for installing new table.

CURTAIN TRACKS

Curtain tracks are mounted to walls with screws.
Refer to Figure 3-10.

SHOWER FOLD DOOR

Refer to Figure 3-11.

1. Remove end cap that covers frame of door by removing screws.
2. Remove screws holding door side frames to walls.
3. Remove entire door frame and fold door.
4. Remove door from frame by sliding out from top frame.
5. Install new door by reversing above procedure.

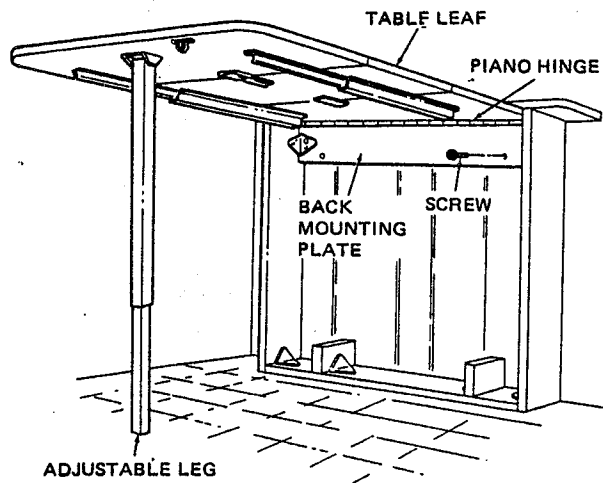

FIGURE 3-9 Fold out table

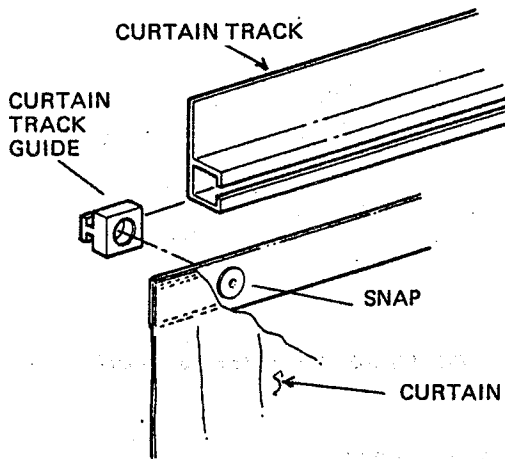
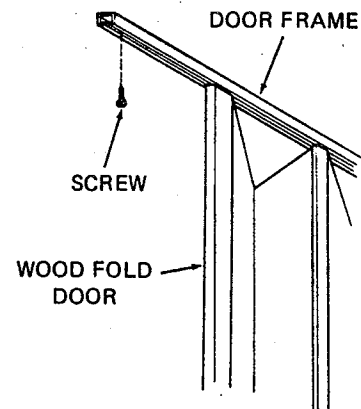

FIGURE 3-10 Curtain track assy

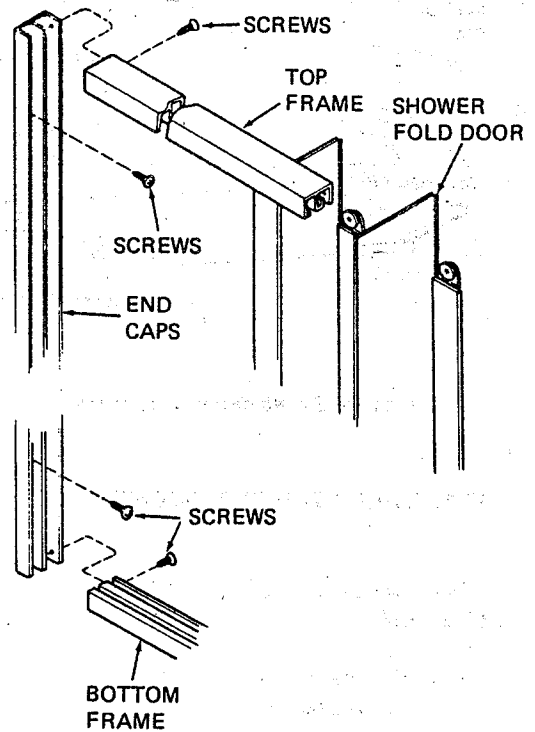

FIGURE 3-11 Folding doors

WOOD FOLD DOOR

Refer to Figure 3-11.

1. Remove screws holding door frame to ceiling.
2. Slide out door from frame.
3. Install new door by reversing above procedure.

HINGED BATHROOM DOOR

1. Remove door latches and hinges.
2. Mark latch location on new door and drill new latch mounting holes.
3. Replace door and hinges.

KITCHEN BACKSPLASH REPLACEMENT

Refer to Figure 3-12.

Removal

If backsplash extends from lower cabinet to overhead cabinet include steps 1-5.

1. Turn off electrical circuits for range hood, vent fan, light and wall plug.
2. Remove screws holding range hood and light cover.
3. Disconnect wires on range hood and light.
4. Remove range hood and light.
5. Remove receptacle wall cover.
6. Trim off old molding where needed with a utility knife.
7. Remove damaged tile board by cutting just above sink base and below overhead cabinets if board has been installed behind these sections.
8. If tile board is bonded, pry off with screw driver. If mechanically fastened, remove staples or screws.

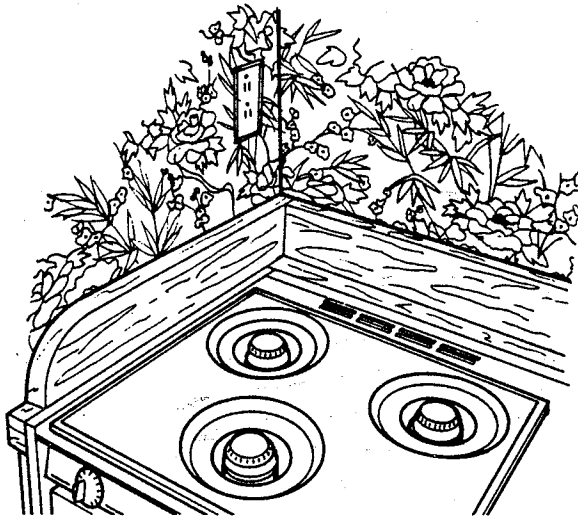

FIGURE 3-12 Back splash

Replacement

1. Cut new tile board to fit area.
2. Use old board for template for size and to cut access holes.
3. Position tile board on wall. Install with staples or screws.
4. Nail cap moldings on exposed edges of tile board.
5. Install receptacle cover.
6. Reinstall vent range hood and light and connect wires.
7. Turn on electrical circuit.

COUNTER TOP REPLACEMENT

Refer to Figure 3-3.

Removal

1. Disconnect water lines from drain and faucets under cabinet top. Remove faucets and sink. (See Plumbing Section.)
2. Remove gas range. Refer to Appliance Section.
3. Remove drawers.
4. Remove all screws from cleat around lower perimeter of counter top. Work from underside of top.
5. Lift off counter top.
6. Remove "T" molding from edges of counter top.

Replacement

1. Install "T" molding on edges of new counter top.
2. New counter top is supplied with cutouts for sink. However, if holes need to be cut, use old counter top as a template.
3. Reinstall faucets. (See Plumbing Section.)
4. Apply caulking material under sink rim.
5. Reinstall sink. (See Plumbing Section.)
6. Tack or staple cove molding to counter top on edges required.
7. Position counter top in place.
8. Reconnect plumbing to sink and faucets. (See Plumbing Section.)
9. Reinstall gas range and drawers.

SIDE ANGLE BRACKET REPLACEMENT

Refer to Figure 3-13.

1. Remove mattress and curtains.
2. Raise side of bunk.
3. Support raised edge of bunk.
4. Remove screws from side angle bracket. Remove bracket.
5. Install new bracket and reverse above procedures.

CABINET BUNK REPLACEMENT

Refer to Figure 3-13

1. Remove mattress.
2. Open bunk to flat position.
3. Remove screws from middle hinge.
4. Remove front half of bunk.
5. Remove screws from rear bunk rail.
6. Remove back section of bunk.
7. Reverse order for installing new bunk.

CABINET BUNK SLIDING DOOR REPLACEMENT

1. Remove mattress.
2. Remove screws or staples holding top door guide slide.

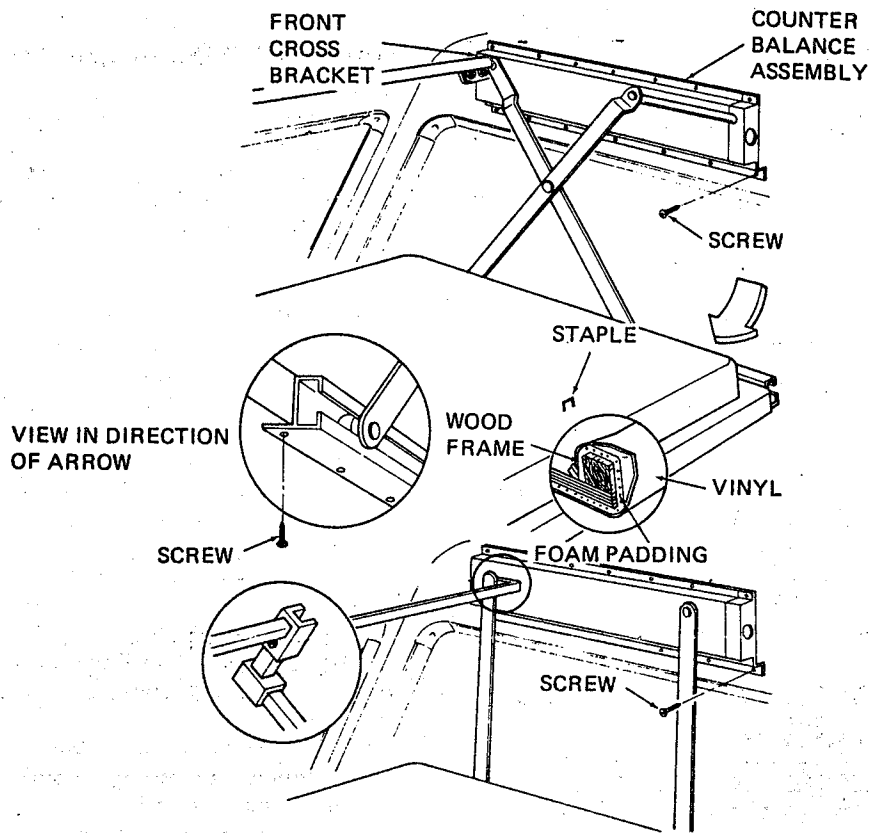

FIGURE 3-13 Pull down bunk and counter balance

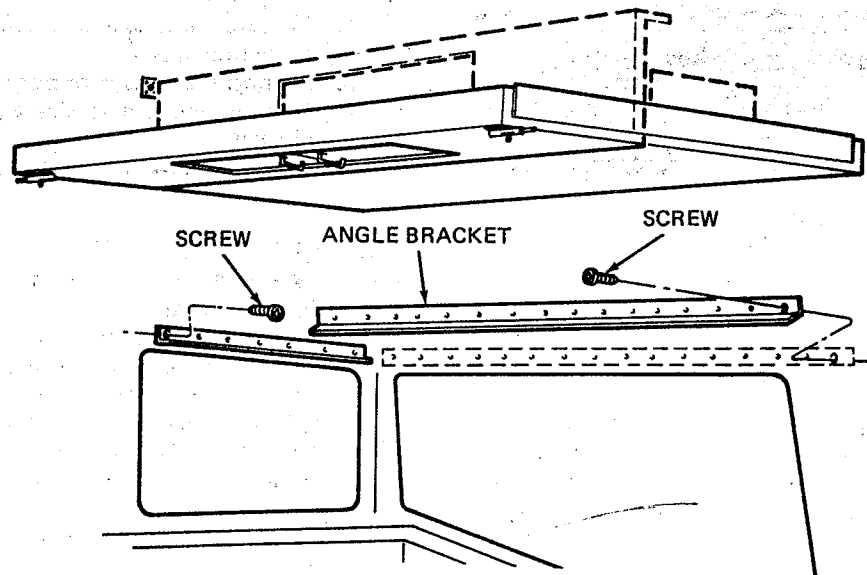

FIGURE 3-14 Cabinet bunk and side angle bracket

3. Remove doors.
4. Remove door handles.
5. Reinstall handles on new door.
6. Install new door.
7. Reinstall door guide slide.

PULL DOWN BUNK COUNTER BALANCE ASSEMBLY

Refer to Figure 3-13.

Removal

1. Remove mattress and curtains.
2. Remove bunk from swing down bracket by removing screws on bottom side.
3. Remove front cross bracket by unbolting from pivot arm.

CAUTION: Swing down arms are under spring loaded tension.

4. Remove counter balance assembly from side of motor home by removing screws.

NOTE: Counter balance tension can be adjusted by increasing or decreasing spring tension through tension adjustment opening in assembly.

ROOM DIVIDER SPINDLE REPLACEMENT

Removal

1. Remove screws holding top and bottom spindle brackets.
2. Remove entire spindle assembly.
3. Install new spindle into spindle bracket with staples or screws. Make sure at least 4 screws are used to prevent spindle from turning in brackets.

CAUTION: Do not scratch ceiling of motor home with exposed screws in bracket.

SOFA BED

To remove entire sofa bed, remove bolts from floor. To remove back of seat remove 4 bolts from bracket and remove back of seat.

ENGINE COVER AIR LEAKAGE

Remove old weather-strip, clean strip surface thoroughly and apply new adhesive coated weather-strip to seal area of engine cover.

Section 4 BODY INTERIOR (SOFT)

WINDOW CURTAINS

Refer to Figure 4-1.

Unsnap old curtain and snap on new curtain.

2. Slide out shade.

3. Install new shade in bracket.

ROMAN SHADES

Refer to Figure 4-1.

1. Unscrew shade from bracket.

VENETIAN BLINDS

1. Remove shade from bracket.

2. Remove bracket from wall.

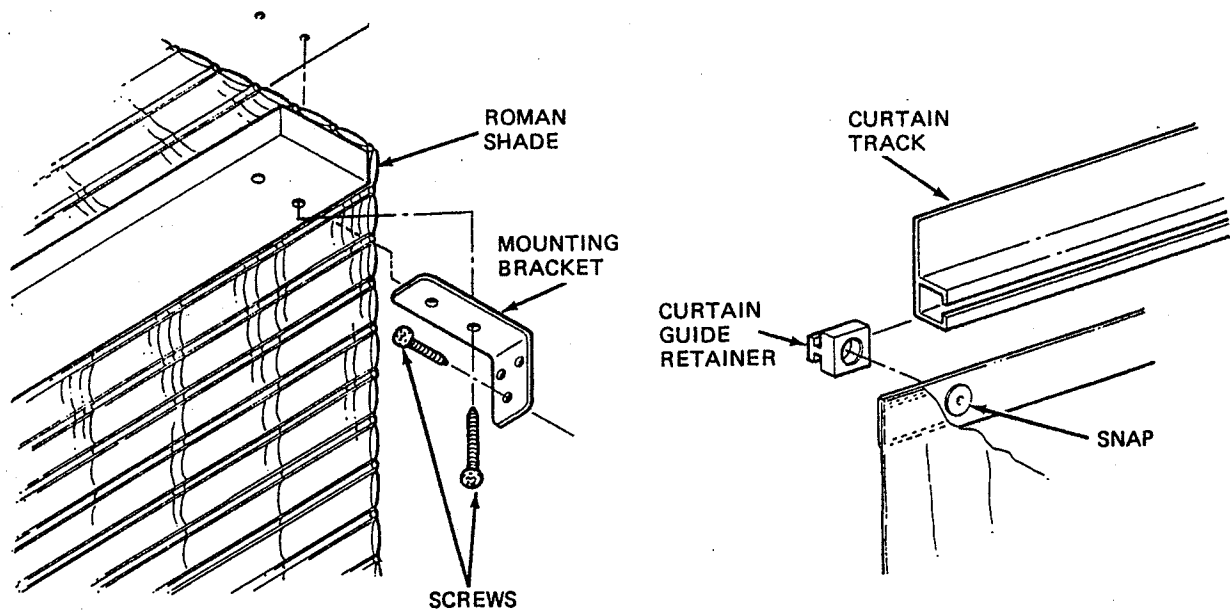

FIGURE 4-1 Roman shade

