

Name:

M. AKRAM

Roll No:

12526

Semester

4th

Assignment:

EET-402

Electrical Machines - II

Teacher Name:

Sir Farhan Khalid Sab

GCUF

Q No. 1 write introduction, Advantages/disadvantages and construction of Three phase induction motor.

* Introduction

The popularity of 3 phase induction motors on board ships is because of their simple robust construction, and high reliability factor in the sea environment. A 3 phase induction motor can be used for different applications with various speed and load requirement.

Electric motors can be found in almost every production process today.

Getting the most out of your application is becoming more and more important in order to ensure cost-effective operations. The three-phase induction motors are the most widely used electric motors in industry.

The run at essentially constant speed from no-load to full-load. However, the speed is frequency dependent and consequently these motors are not easily adapted to speed control. We usually prefer d.c motors when large speed variations are required.

* Advantages

- i) it has simple and rugged construction.
- ii) it is relatively cheap.
- iii) it requires little maintenance.
- iv) it has high efficiency and reasonable good power factor.
- v) it has self-starting torque.

* Disadvantages

- ① it is essentially a constant speed motor and its speed cannot be changed easily.
- ② its starting torque is inferior to DC shunt motor.

* construction

The three phase induction motor is the most widely used electrical motor. Almost 80% of the mechanical power used by industries is provided by three phase induction motors because of its simple and rugged construction low cost good operating characteristics absence of commutator and speed regulation.

In three phase induction motor the power winding through induction.

The 3-phase induction motor has two main parts (i) stator (ii) rotor. The rotor is separated from the stator by a small air-gap which ranges from 0.4mm to 4mm, depending on the power of the motor.

Stator

Stator: As its name indicates stator is a stationary part of induction motor. A stator winding is placed in the stator of induction motor and the three phase supply given to it. Stator is made up of number of stampings in which different slots are cut to receive 3 phase winding circuit which is connected to 3 phase AC supply.

$$N_s = 120 \frac{f}{p}$$

N_s = Synchronous speed

f = frequency p = no. of poles.

P.T.O

Page 3

Stator of Three phase induction motor

i) Stator Frame

It is the outer most part of the three phase induction motor. Its main function is to support the stator core and the field winding. It acts as a covering and it provides protection and mechanical strength to all the inner parts of the induction motor.

ii) Stator core

The main function of the stator core is to carry the alternating flux. In order to reduce the eddy current loss, the stator core is laminated. These laminated types of structure are made up of stamping which is about 0.4 to 0.5 mm thick.

iii) Stator winding or Field winding

The slots on the periphery of stator core of the motor carries three phase windings. This three phase winding is supplied by three phase ac supply. The squirrel cage motor is mostly started by star delta starter and hence the stator of squirrel cage motor is delta connected.

* Rotor

The rotor is a rotating part of a induction motor. The rotor is connected to the mechanical load through the shaft.

Squirrel cage rotor

Squirrel cage three phase induction motor. The rotor of the squirrel cage three phase induction motor is cylindrical in shape and have slots on its periphery. The slots are not made parallel to each other but are bit skewed.

P. T. O

Advantages of squirrel cage induction motor

- i) Its construction is very simple and rugged.
- ii) As there are no brushes and slip ring these motors require less maintenance.

Application

Squirrel cage induction motor is used in lathes, drilling machine, fan blower printing machines etc.

wound rotor.

Slip ring or wound three phase induction motor: In this type of three phase induction motor the rotor is wound for the same number of poles as that of stator but it has less number of slots and has less turns per phase of a heavier conductor.

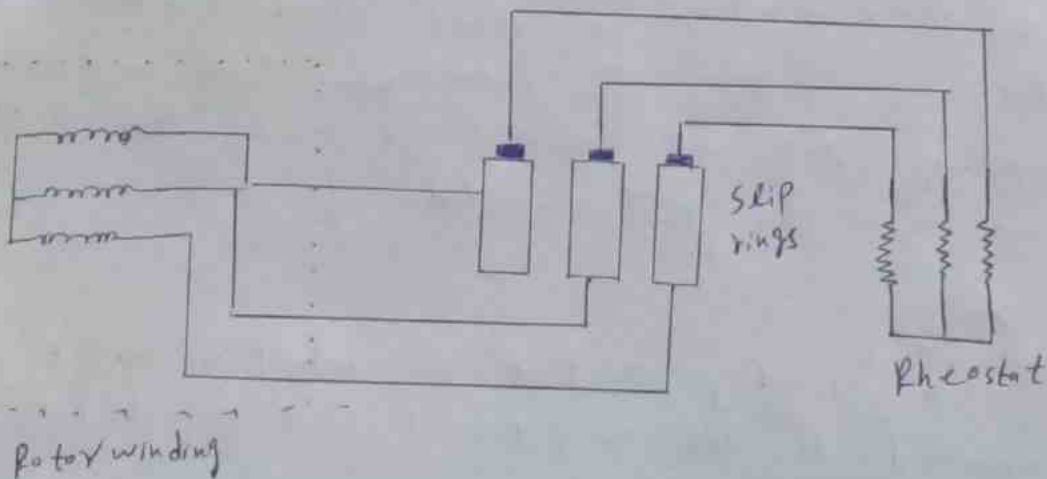

Advantages of slip ring induction motor

It has high starting torque and low starting current. Possibility of adding additional resistance to control speed.

Application: Slip ring induction motor are used where high starting torque is required i.e. in hoists, cranes, elevator etc.

Page 5

Q No 2: write operation principle (working) of Three Phase Induction motor.

Operation principle

In an AC motor, there is a ring of electromagnets arranged around the outside (making up the stator) which are designed to produce a rotating magnetic field. Inside the stator, there is a solid metal axle, a loop of wire a coil a squirrel cage made of metal bars and interconnections or some other freely rotating cages metal part that can conduct electricity. Unlike in a DC motor where you send power to the inner rotor in an AC motor you send power to the outer coils that rotate around the outside of the motor. The rotor suspended inside the magnetic field is an electrical conductor. The magnetic field is constantly changing (because it's rotating) so according to the laws of electromagnetism (Faraday's own term) an electric current inside the rotor if the conductor is a ring or a wire the current flows around it in a loop. If the conductor is supply a solid piece of metal eddy current currents swirl around it instead.

Either own magnetic field and according to another law of electromagnetism (Lenz's law) tries to stop whatever it is that causes it - the rotating magnetic field - by rotating as well

P.T.O

Three-Phase Rotating Fields

The three-phase induction motor also operates on the principle of a rotating magnetic field. The following discussion shows the stator windings can be connected to a three-phase ac input and have a resultant magnetic field that rotates.

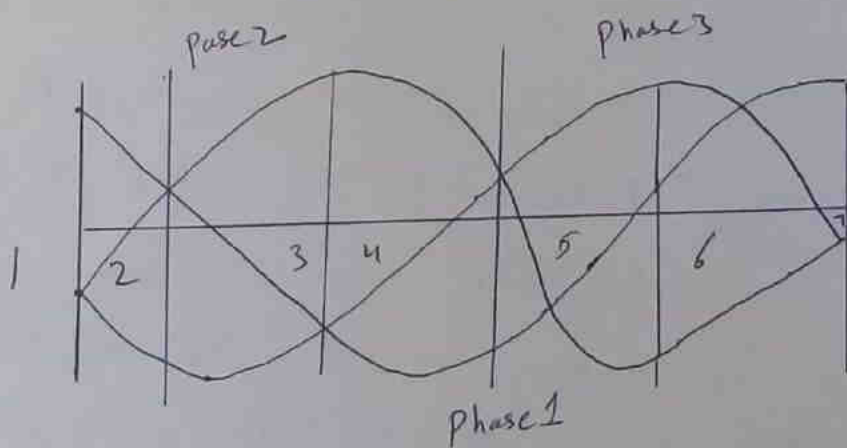
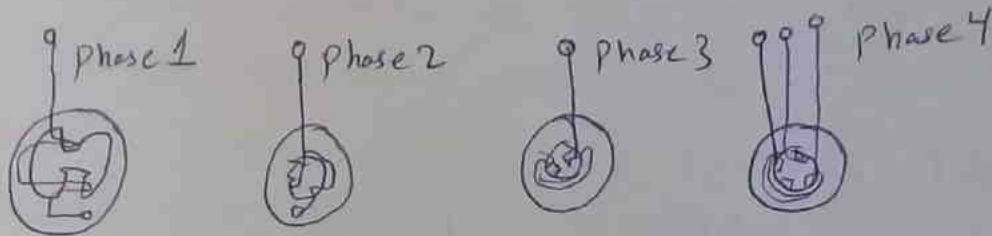

The results of this analysis are shown for voltage point 1 through 7 in figure 8-7. At point 1, the magnetic field in coils 1-1A is maximum with polarities as shown. At the same time, negative voltages are being felt in the 2A and 3A windings. These create weaker magnetic fields which end to aid the 1-1A field. At point 2, maximum negative voltage is being felt in the 3-3A windings. This creates a strong magnetic field which in turn is aided by the weaker fields in 1-1A and 2-2A. As each point on the voltage graph is analyzed, it can be seen that the resultant

Q.No.3 Discuss different types of Starter for three Phase induction Motor.

DOL (Direct on-Line starter)

The Direct on line (DOL) starter is the simplest and the most inexpensive of all starting methods and is usually used for squirrel cage induction motors.

It directly connects the contacts of the motor to the full supply voltage. The starting current is very large, normally 6 to 8 times the rated current. The starting torque is likely to be 0.75 to 2 times the full load torque. In order to avoid excessive voltage drop in the supply line due to high starting current the DOL starter is used only for motors with a rating of less than 5kW. There are safety mechanisms inside the DOL starter which provides protection to the motor as well as the operation of the motor.

The power and control circuits of induction motor with DOL starter and the picture of contactor are shown below.

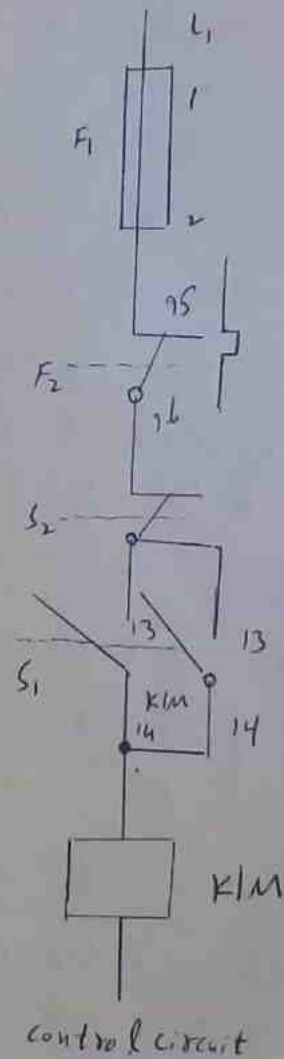
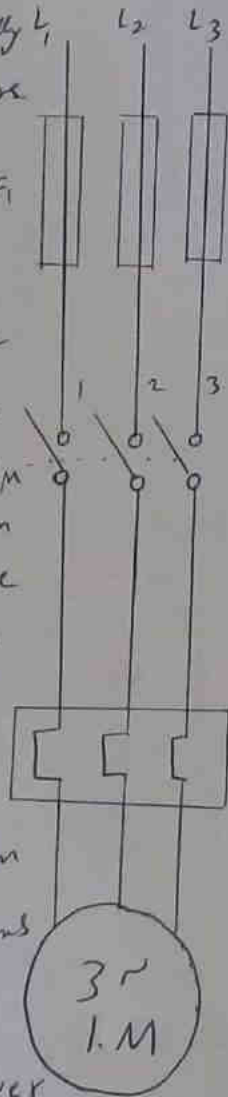

Star-Delta Starter

The star delta starting is a very common type of starter and extensively used compared to the other types of the starters. This method used reduces supply voltage in starting. Figure shows the connection of 3 phase induction motor with a star-delta starter. The method achieved low starting current by first connecting the stator winding in star configuration and then after the motor reaches a certain speed through switch changes the winding arrangements from star to delta configuration. By connecting the stator windings first in star and then delta the line current drawn by the motor at starting is reduced to one-third as compared to starting current with the windings connected in delta. All the time of starting

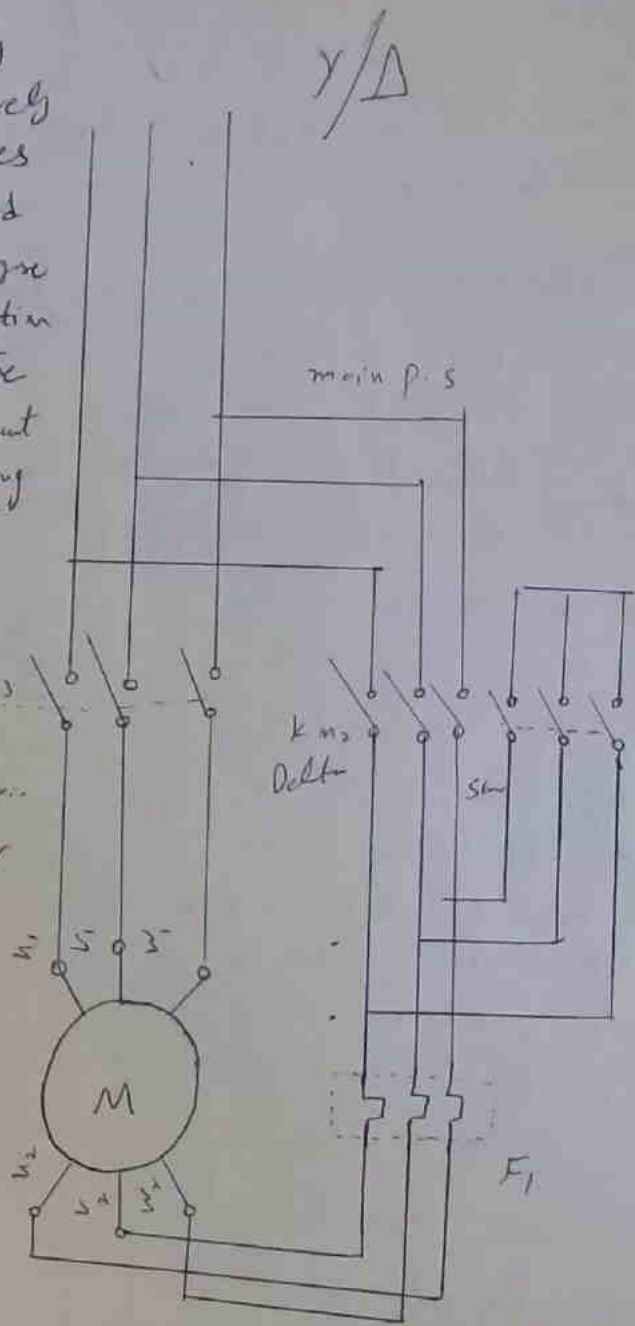

when the stator windings are star connected, each stator phase gets voltage $V_L/\sqrt{3}$ where V_L is the line voltage. Since the torque developed by an induction motor is proportional to the square of the applied voltage, star-delta starting reduces the starting torque to one-third that obtained by direct delta starting.

Auto Transformer starter Page 9

The operation principles of auto transformer method is similar to the star delta starter method. The starting current is limited by (using a three phase auto transformer) reduce the initial stator applied voltage. The auto transformer starter is more expensive, more complicated in operation and bulkier in construction when compared with the star-delta starter method. But an auto transformer starter is suitable for both star and delta connected motors and the starting current and torque can be adjusted to a desired value by taking the current tapping from the auto transformer. when the star delta method is considered, voltage can be adjusted only by factor of $\frac{1}{\sqrt{3}}$

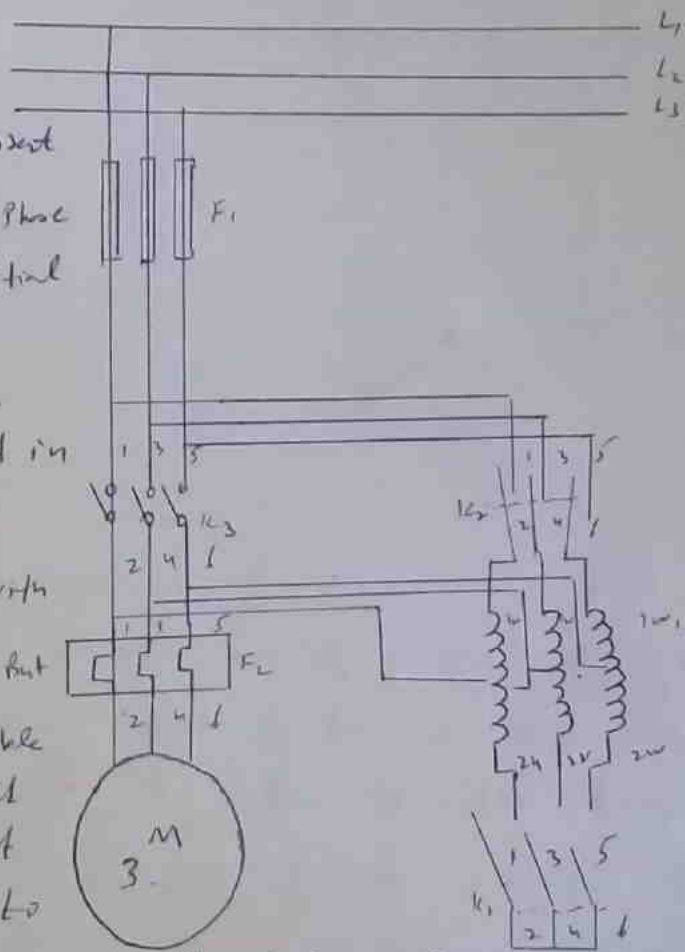

1. operation by a two position switch i.e manually / automatically using a timer to change over from start to run position.
2. In starting position supply is connected to stator windings through an auto transformer which reduces applied voltage to 50-60 and 70% of normal value depending on tapping used.
3. reduced voltage reduces current in motor windings with 50% tapping used motor current is halved and supply current will be half of the motor current.
4. starters used in larger industries it is larger in size and expensive.

Rotor Impedance starter Page 10

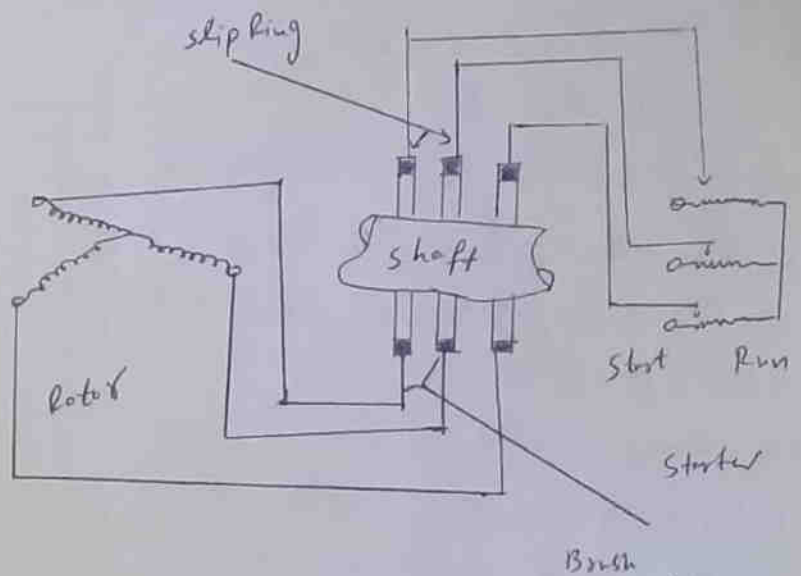
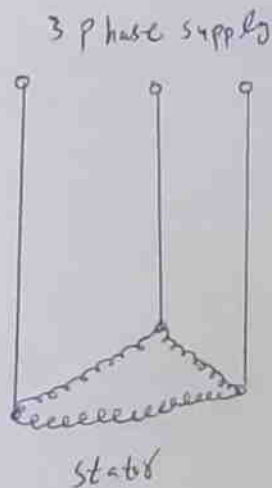

This method allows external resistance to be connected to the rotor through slip rings and brushes. Initially, the rotor resistance is set to maximum and is then gradually decreased as the motor speed increases until it becomes zero.

The rotor impedance starting mechanism is usually very bulky and expensive when compared with other methods.

It also has very high maintenance costs. Also a considerable amount of heat is generated through the resistors.

When current runs through them. The starting frequency is also limited in this method. However the rotor impedance method allows the motor to be started while on load.

Figure shown the connection of a 3 phase induction motor with rotor resistance starter.

Thank you Sir,