

1. Overview of Foundation Engineering BFC 4043

Engineering ????
Foundation

NOR AZIZI YUSOFF

KUITTHO

C17-001-05

Ext: 1128, H/p: 013-7618223

azizy@kuittho.edu.my





MY FAMILY.....



MY VISIT.....



MY DREAMS.....

- TO GIVE A BETTER UNDERSTANDING ON FOUNDATION ENGINEERING
- To dev. generic skills for 'THE FUTURE LEADERS...'
- give more emphasis on practical needs
- of coz... give a good mark for you....
- punish for those who wish to...
- Acknowledge.. For those excellent!

R U L E S

- **Be Honest!!**
- Always wear your matric card
- Be like a students nor rockers, 'makcik nak pegi pasar', 'protégé'
- 80 % attendance!

ISI NYA

- 1.0 Asas Cetek (7 jam kuliah)
- 1.1 Jenis-jenis asas, pemilihan dan kriteria reka bentuk, mod-mod kegagalan.
- 1.2 Teori-teori am keupayaan galas : Prandtl, Terzaghi, Meyerhof dan Hansen. Kesan air bumi.
- 1.3 Keupayaan galas pasir dan tanah liat.
Teori Pengukuhan satu dimensi Terzaghi. Ujian Pengukuhan dalam makmal dan pengukuhan tapak bina.

- 2.0 Asas Dalam (11 jam kuliah)
- 2.1 Jenis-jenis asas dalam; (A) Bahan (B) Fungsi, Pengkelasannya; cerucuk galas hujung dan cerucuk geseran.
- 2.2 Analisis Keupayaan Cerucuk : Formula Statik, dinamik dan ujian pembebanan.
- 2.3 Meraka bentuk cerucuk tunggal, cerucuk berkumpul,
- 2.4 Kekukuhan dan enapan cerucuk.
- 2.5 Pembinaan Asas dan Isu Berkaitan

1

APLIKASI WEB

LINK IPTA

UM UPSI
UTM UNIMAS
UKM UMS
USM KUM
UPM KUSTEM
UTM KUTKM
UUM KUTEM
UIA KUKUM

RENUNGAN

Renungan

Razulullah s.a.w. bersabda maksudnya :
"Orang yang meminta kembali barang
pembayarannya itu sama halnya seperti seekor
anjing yang mustahil lalu dimakan kembali
muntahnya itu." (H.R. Bukhari)

KUITTHO Kolej Universiti Teknologi
Tun Hussein Onn

SAJINS & TEKNOLOGI

SCIENCE & TECHNOLOGY

MALAY ENYER ENGLISH

FORUM PERDANA EHWAL ISLAM
Masa: 8.00 Malam
Tarikh: 7 Ogos 2004 (SABTU)

© Kolej Universiti Teknologi Tun Hussein Onn, Beg Bekunci 101, 86400 Parit Raja, Batu Pahat, Johor Darul Takzim
Tel : 607-4630000 / 607-4636113, Fax : 607-4632337

Blackboard Learning System™ (Release 6) Entry Page - Microsoft Internet Explorer

File Edit View Favorites Tools Help

Address http://lmu.kuittho.edu.my/

Blackboard Learning System - Basic Edition™ (Release 6)

Welcome!

Welcome to the Blackboard e-Education platform-- designed to transform the Internet into a powerful environment for the educational experience.

To log in, please click on the Login icon on the left.

KUITTHO's Learning Management System
 E-Learning @ lmu.kuittho.edu.my

username:
 Azizy1
 Password:
 12345

Copyright © 1997-2004 Blackboard Inc. Patents Pending. All Rights Reserved.
 Accessibility information can be found at <http://access.blackboard.com>.

http://lmu.kuittho.edu.my/webapps/login

start BKA 5023 ASAS 0405... Microsoft PowerPoint... KUITTHO -- 6 0G05... Blackboard Learning... 2:58 PM

Blackboard Learning System™ (Release 6) - Microsoft Internet Explorer

File Edit View Favorites Tools Help

Address http://lmu.kuittho.edu.my/webapps/portal/frameset.jsp

Home Help Logout
 My Institution Courses

Welcome, azizy1 Contents Layout

My Announcements

- Makluman Untuk Staf Akademik
- Enroll in the Ten Multimedia Courseware Course Today !!!

[more...](#)

My Calendar

No calendar events have been posted today.

[more...](#)

Learn More About Course Cartridges

Take your course Web site development to the next level by adding a Blackboard Course Cartridge containing pre-packaged instructional course materials, professionally produced by one of the many **Publisher Partners** of Blackboard.

To get started visit <http://cartridges.blackboard.com> and search for available cartridges in your subject discipline.

My Courses

Courses in which you are enrolled:

- BKA5023: KEJURUTERAAN ASAS

No Announcements.

My Tasks

No tasks displayed.

[more...](#)

[Announcements](#)
[Calendar](#)
[Personal Information](#)
[Tasks](#)
[View Grades](#)
[Send E-mail](#)
[User Directory](#)
[Address Book](#)

http://lmu.kuittho.edu.my/webapps/portal/frameset.jsp?tab=courses&url=/bin/common/course.pl?course_id=_1160_1

start BKA 5023 ASAS 0405... Microsoft PowerPoint... KUITTHO -- 6 0G05... Blackboard Learning... 3:00 PM

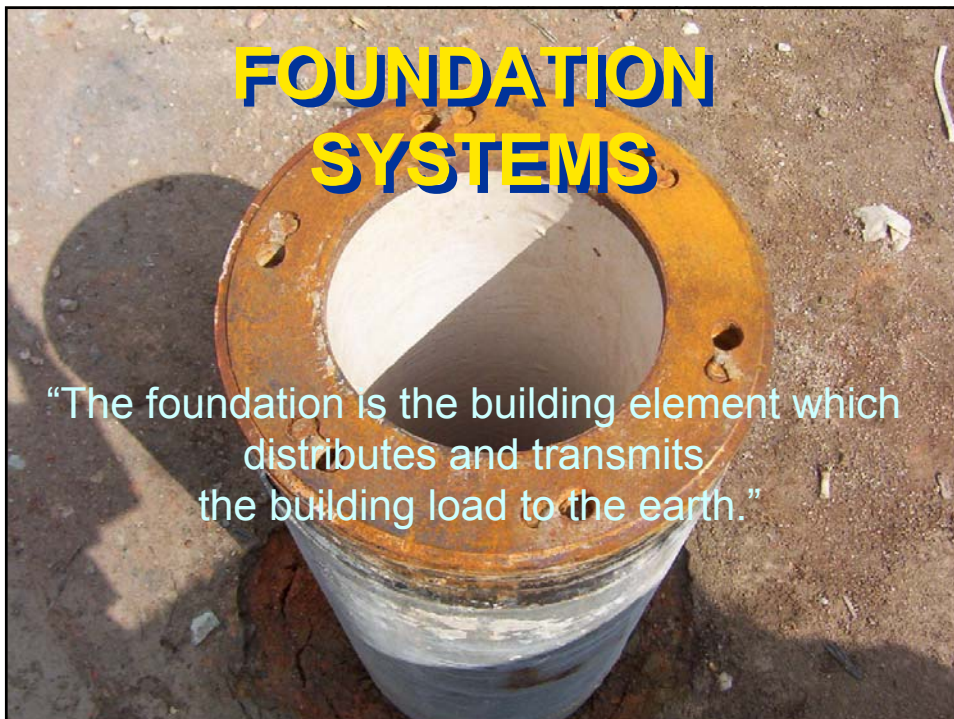

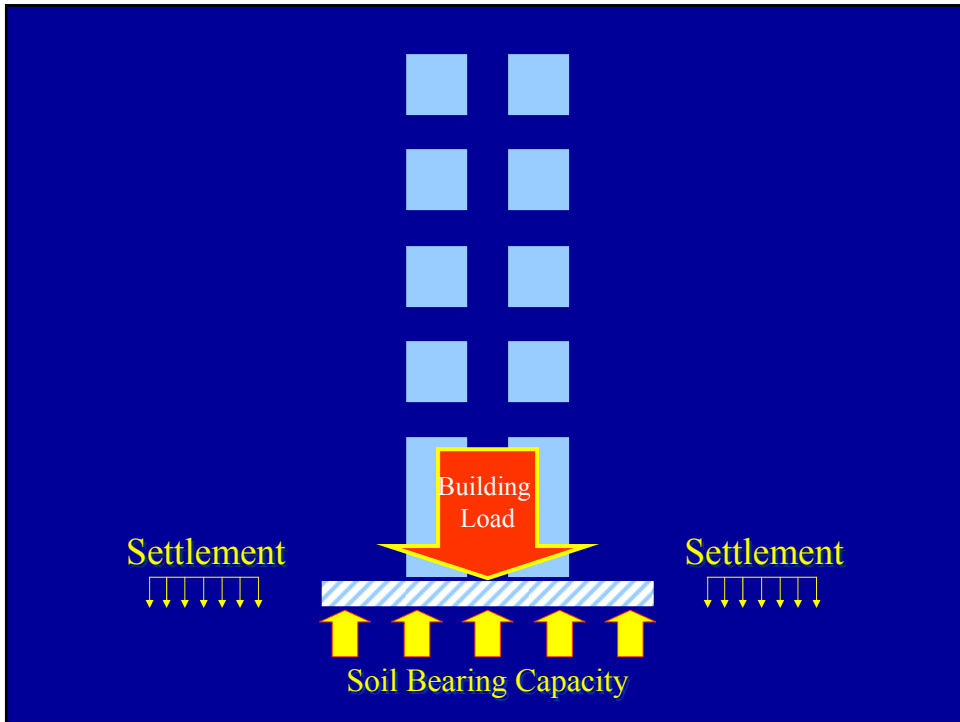

QUIZ 1..... 12/7/06

600 N



BEBAN

$\phi=0$; $C = 35 \text{ kN/m}^2$

TANAH

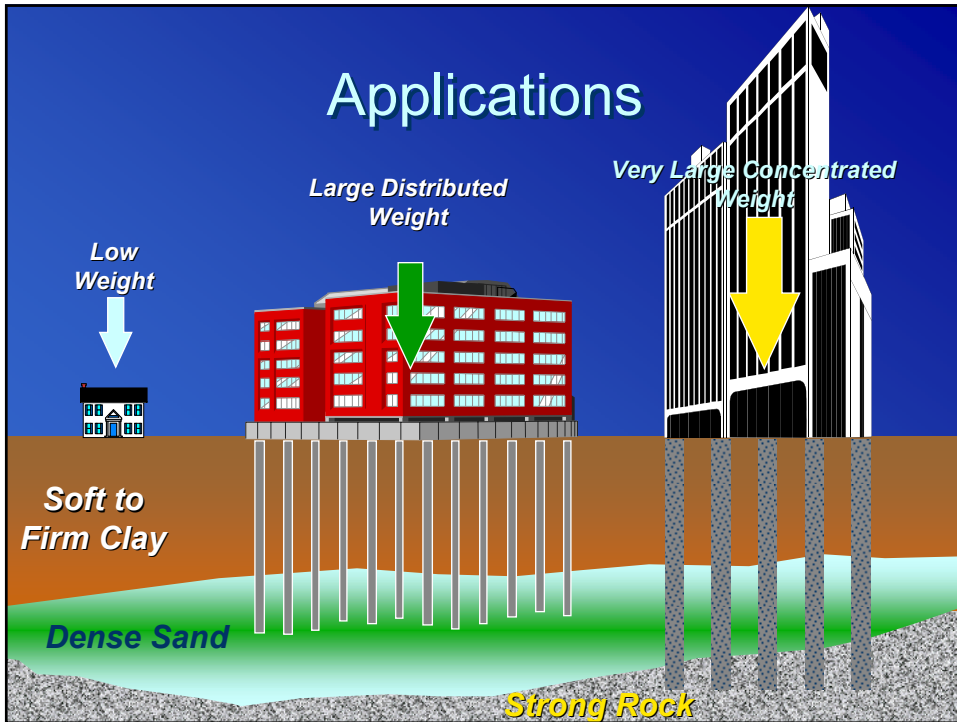

“All foundations will settle to some extent”

Settlement Magnitude:

Usually less than 1”

Uniform Settlement:

Acceptable if within the 1”

Differential Settlement:

Unacceptable if differences exceed the 1”

What are the different loads which constitute the building load?

Dead Load
Live Load
Wind Loads
Thrusts
Seismic

SOIL TYPES:		SOIL	UNIFIED SOIL CLASSIFICATION SYSTEM						
			MAJOR DIVISIONS	GROUP SYMBOLS	TYPICAL NAMES				
Gravel Sand Silt Clay	GOOD	↑	COARSE GRAINED SOILS (More than 50% of coarse fraction is LARGER than the No. 200 sieve size)	CLEAN GRAVELS (Little or no fines)	GW	Well graded gravels, gravel-sand mixtures, little or no fines.			
				GRAVELS (More than 50% of coarse fraction is LARGER than the No. 4 sieve size)	GP	Poorly graded gravels or gravel-sand mixtures, little or no fines.			
				GRAVELS WITH FINES (Appreciable amt. of fines)	GM	Silty gravels, gravel-sand-silt mixtures.			
					GC	Clayey gravels, gravel-sand-clay mixtures.			
			FINE GRAINED SOILS (More than 50% of material is SMALLER than No. 200 sieve size)	BAD	↓	SANDS (More than 50% of coarse fraction is SMALLER than the No. 4 sieve size)	CLEAN SANDS (Little or no fines)	SW	Well graded sands, gravelly sands, little or no fines.
							SANDS WITH FINES (Appreciable amt. of fines)	SP	Poorly graded sands or gravelly sands, little or no fines.
						SILTS AND CLAYS (Liquid limit LESS than 50)	SM	Silty sands, sand-silt mixtures.	
							SC	Clayey sands, sand-clay mixtures.	
							SILTS AND CLAYS (Liquid limit GREATER than 50)	ML	Inorganic silts and very fine sands, rock flour, silty or clayey fine sands or clayey silts with slight plasticity.
								CL	Inorganic clays of low to medium plasticity, gravelly clays, sandy clays, silty clays, lean clays.
HIGHLY ORGANIC SOILS	OL	Organic silts and organic silty clays of low plasticity.							
	OH	Organic clays of medium to high plasticity, organic silts.							
	PI	Peat and other highly organic soils.							

BOUNDARY CLASSIFICATIONS: Soils possessing characteristics of two groups are designated by combinations of group symbols.

How is the bearing capacity of a soil determined ?

1. Building Code provides minimum values that can be used for some structures.
2. Subsurface Exploration
 - Test Pits (digging a hole)
 - Test Borings (drilling a hole with a hollow auger)In either case soil samples are obtained and tested in a laboratory.

The soil samples are :

1. Classified
2. Properties determined:
 - density
 - moisture content
 - shear strength
 - void ratio
 - bearing capacity
 - liquid and plastic limits
 - plasticity index

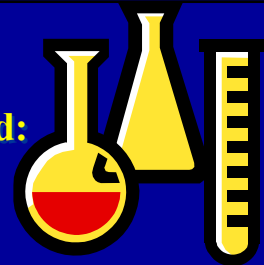

CLIMATIC FEATURES

1. Frost line
2. Expansive soil
3. Groundwater
4. Hydrostatic pressure

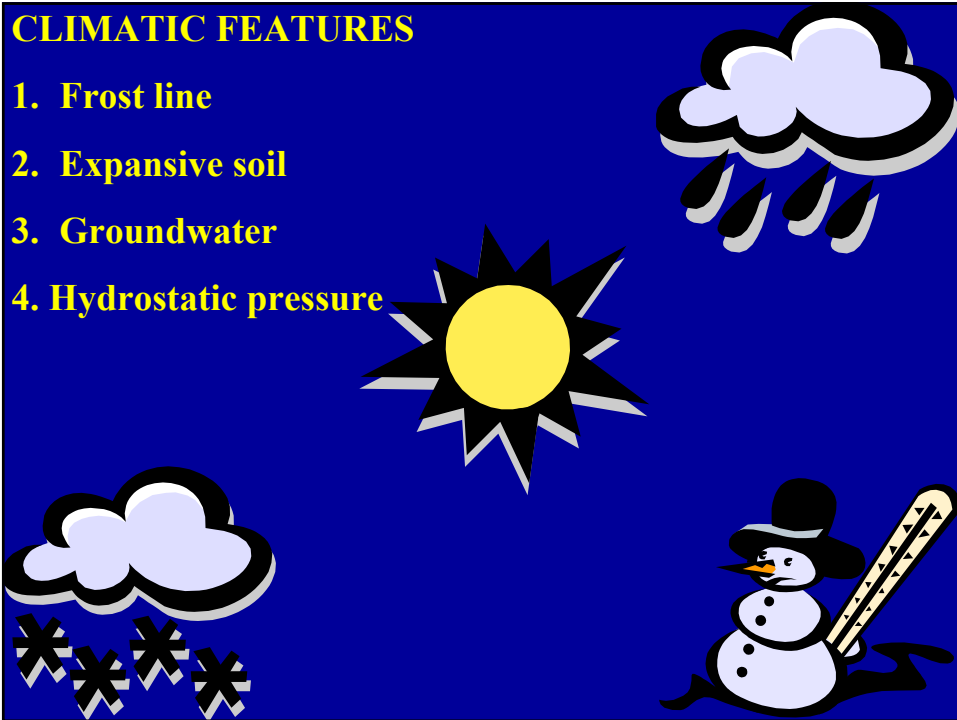

FOUNDATIONS.....

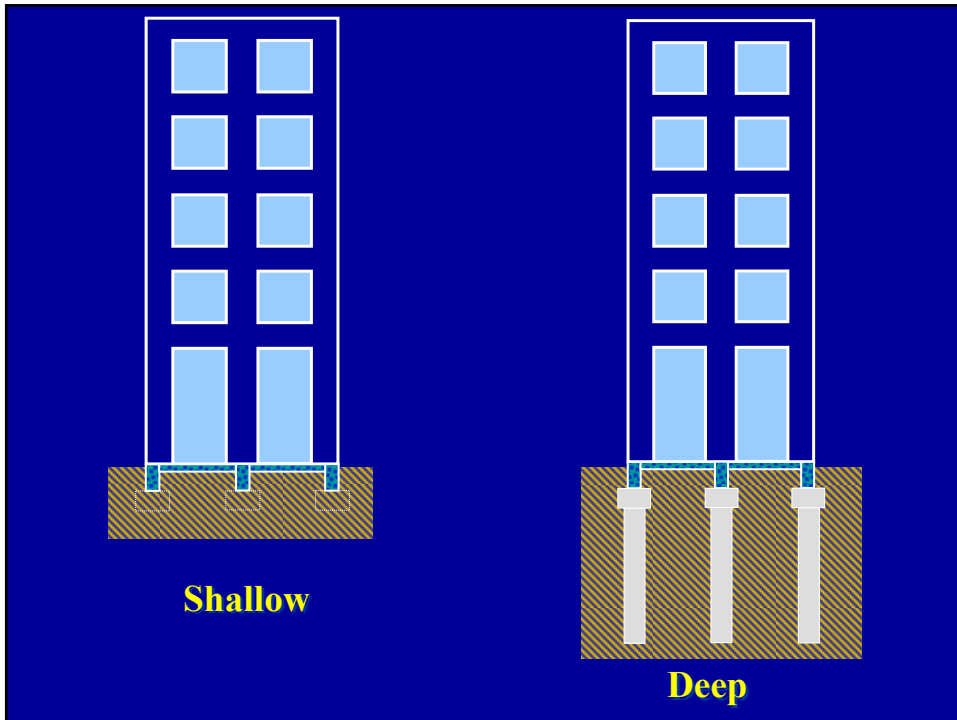

SHALLOW FOUNDATIONS

“Transfer building load at or near soil surface”

1. Footings
 - Column
 - Strip, Spread
 - Wall
 - Combined
2. Slabs
 - On-grade
 - Crawlspace
 - Basement
3. Mat or Raft

SHALLOW FOUNDATIONS

PAD IS
CENTERED
UNDER
COLUMN

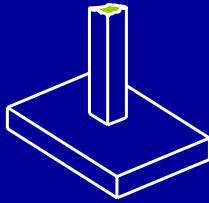

COLUMN FOOTING

PROP. LINE

EXTERIOR
COLUMN

1ST INTERIOR
COLUMN

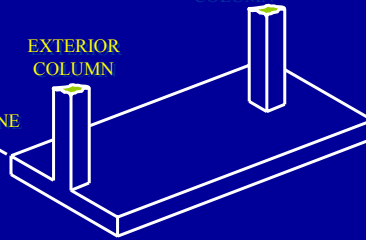

COMBINED FOOTING

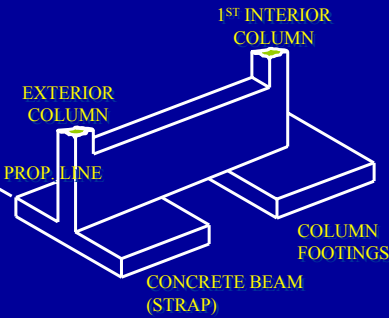

CANTILEVER FOOTING



FOOTING IS
CENTERED
UNDER WALL

WALL FOOTING

SHALLOW FOUNDATIONS

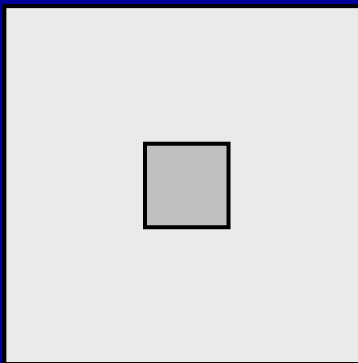

PLAN

DOWNWARD COLUMN LOAD

REINFORCING STEEL
IN BOTH DIRECTIONS
IN BOTTOM FACE OF
FOOTING RESISTS
TENSIONS CAUSED
BY BENDING

BENDING OF FOOTING
CAUSES COMPRESSION IN
TOP FACE AND TENSION
IN BOTTOM FACE

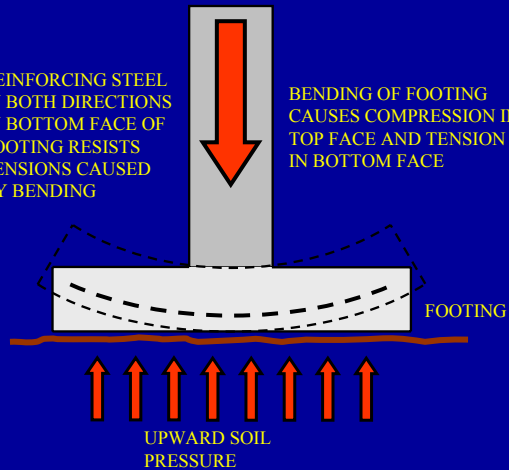

SECTION

SINGLE COLUMN FOOTING

SHALLOW FOUNDATIONS

Footings

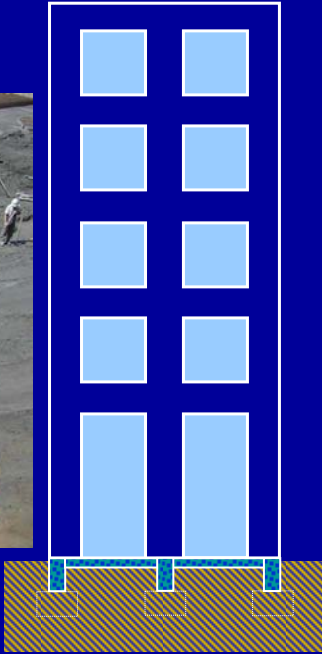

SHALLOW FOUNDATIONS

Types of Substructures: Slab on-grade

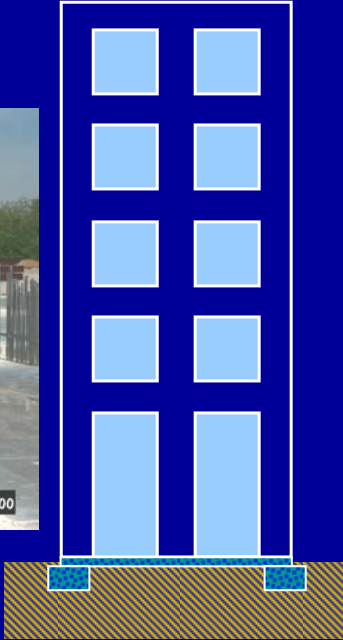

SHALLOW FOUNDATIONS

Slab on-grade



SHALLOW FOUNDATIONS

Types of Substructures:
Crawlspace

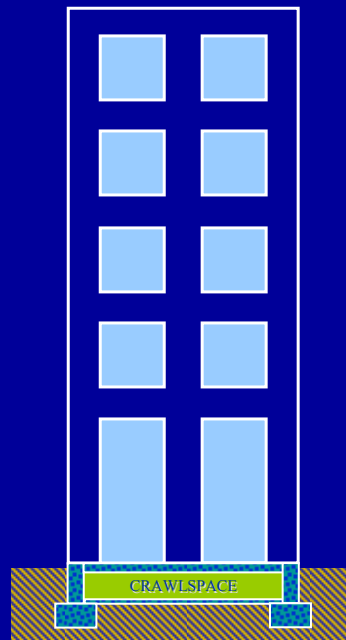

SHALLOW FOUNDATIONS

Types of Substructures:
Basement

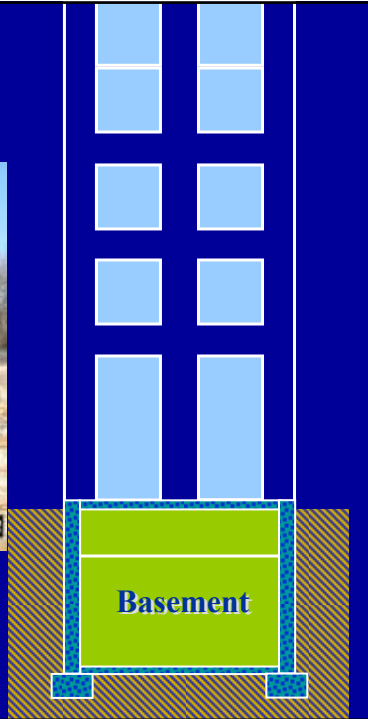

SHALLOW FOUNDATIONS

Types of Substructures:
Basement



SHALLOW FOUNDATIONS

Types of Substructures:
Basement



SHALLOW FOUNDATIONS

Types of Substructures:
Basement

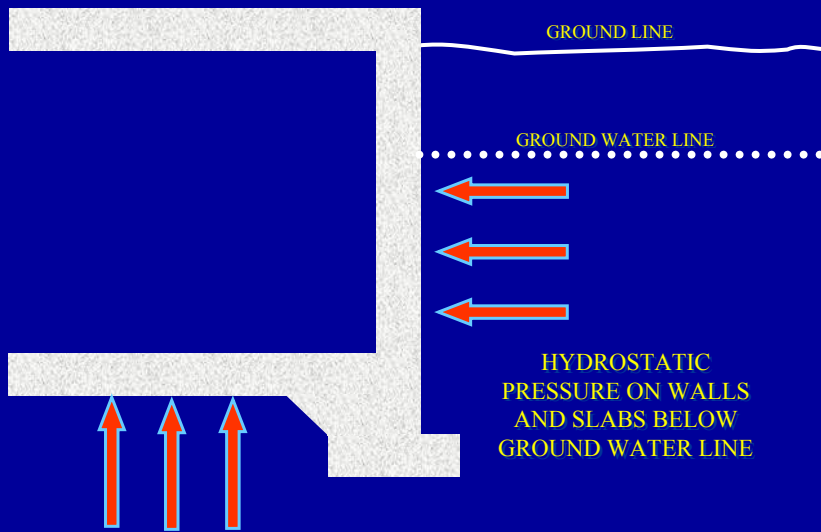

SHALLOW FOUNDATIONS

Types of Substructures:
Basement



SHALLOW FOUNDATIONS

Types of Substructures:
Mat or Raft

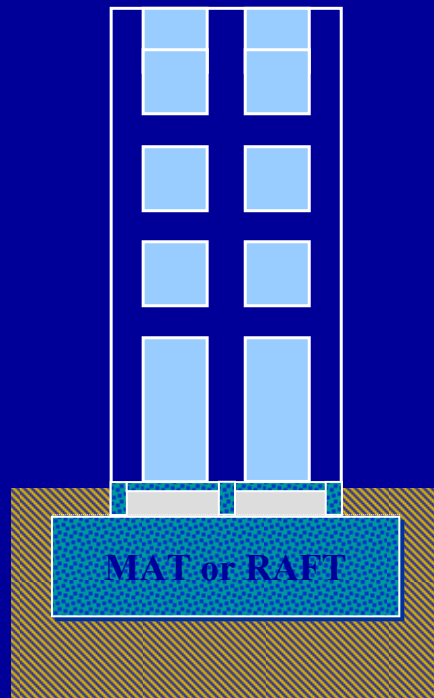

DEEP FOUNDATIONS

“Transfer building load far below soil surface”

1. Drilled Piers/Caisson
 - Friction
 - End Bearing
 - Belled
 - Socketed
2. Piles
 - Friction
 - End Bearing

DEEP FOUNDATIONS

DRILLED PIER/CAISSON

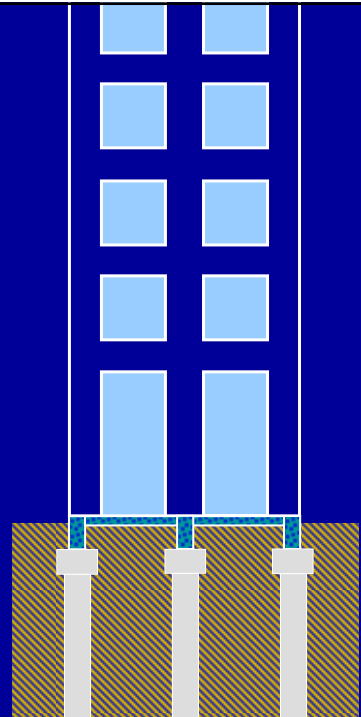

**DEEP FOUNDATIONS
DRILLED PIER/CAISSON**

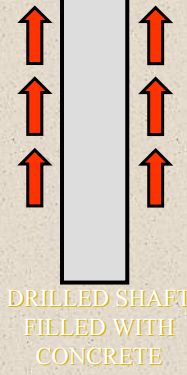

FRICTION
BETWEEN PILE
AND SOIL.

DRILLED SHAFT
FILLED WITH
CONCRETE

**DEEP FOUNDATIONS
DRILLED PIER/CAISSON**



**DEEP FOUNDATIONS
DRILLED PIER/CAISSON**



**DEEP FOUNDATIONS
DRILLED PIER/CAISSON**



DEEP FOUNDATIONS
PIER /CAISSON – PIER CAPS



DEEP FOUNDATIONS
BELLED PIER /CAISSON

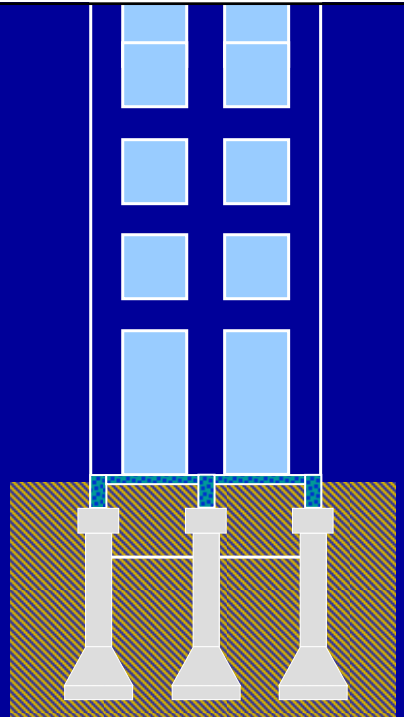

DEEP FOUNDATIONS
BELLED PIER /CAISSON

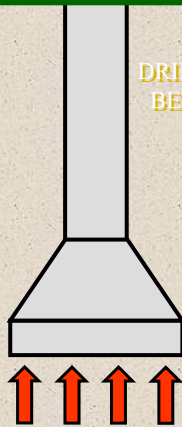
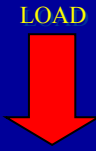

DRILLED SHAFT AND
BELL FILLED WITH
CONCRETE

BELL

BEARING PRESSURE
UNDER BELL

DEEP FOUNDATIONS
Driven Piles

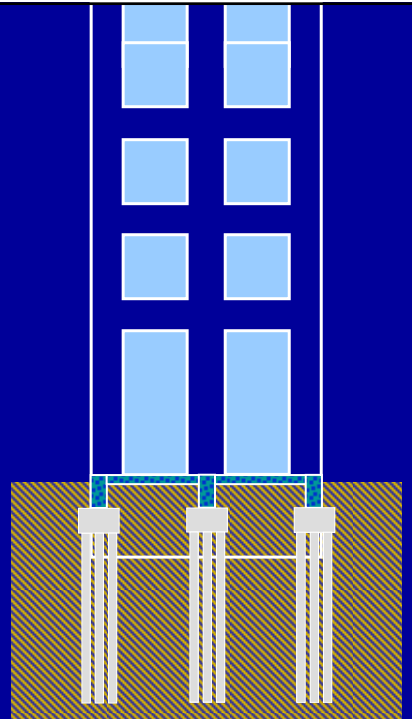

DEEP FOUNDATIONS

Driven Piles

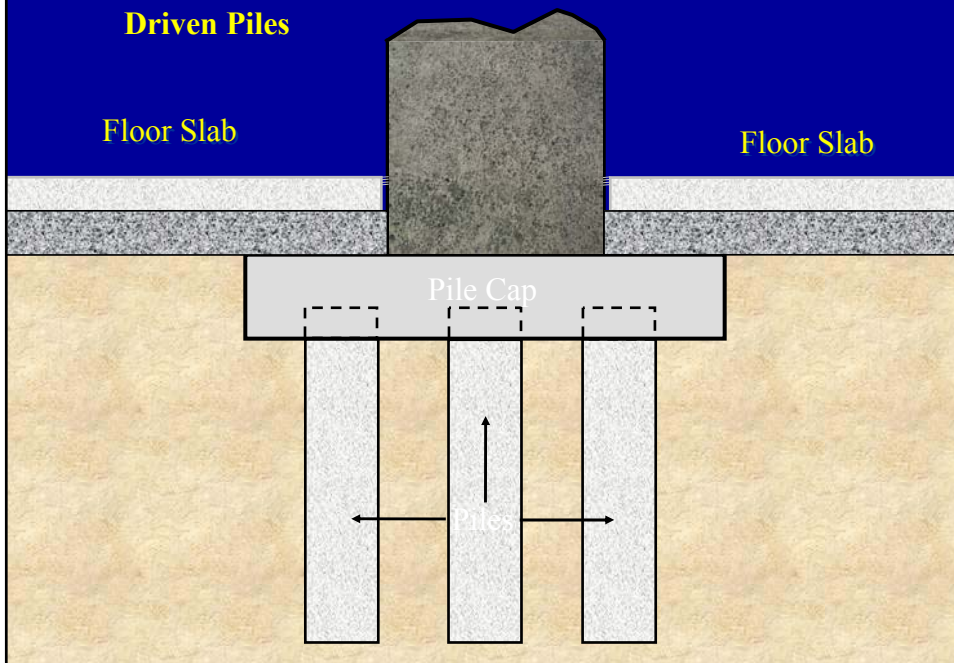

DEEP FOUNDATIONS

Driven Piles - Types of Pile Caps:

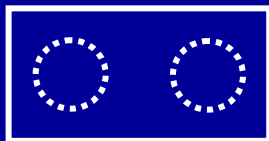

2 Pile Cluster

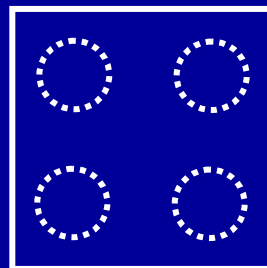

4 Pile Cluster

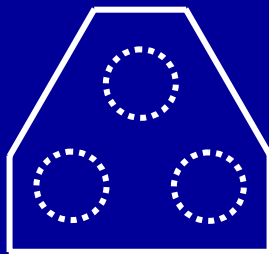

3 Pile Cluster

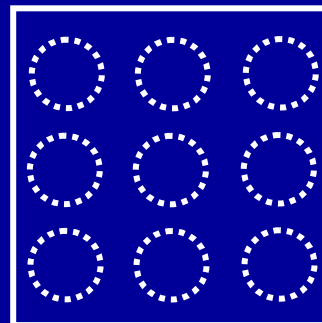

9 Pile Cluster

DEEP FOUNDATIONS

Types of Piles:

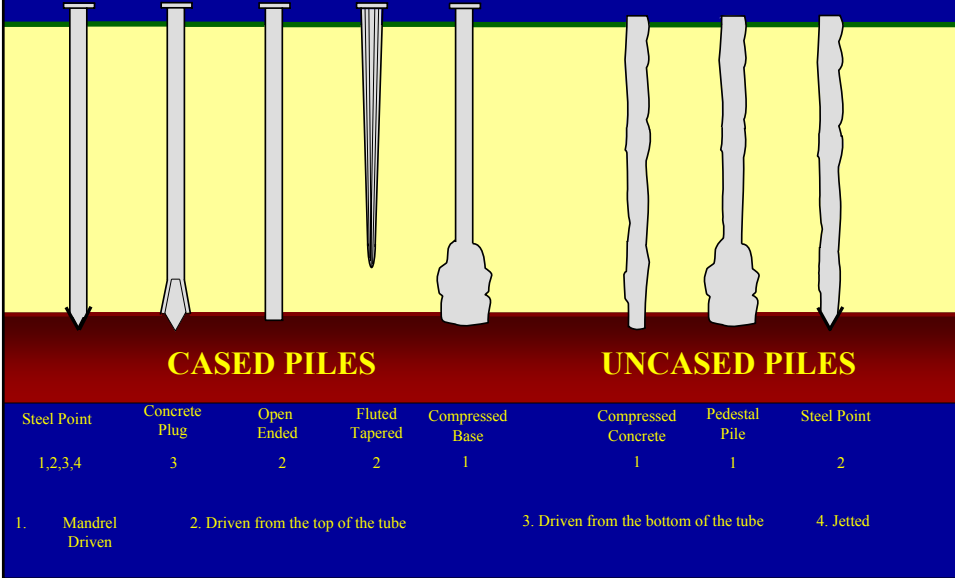

PILES

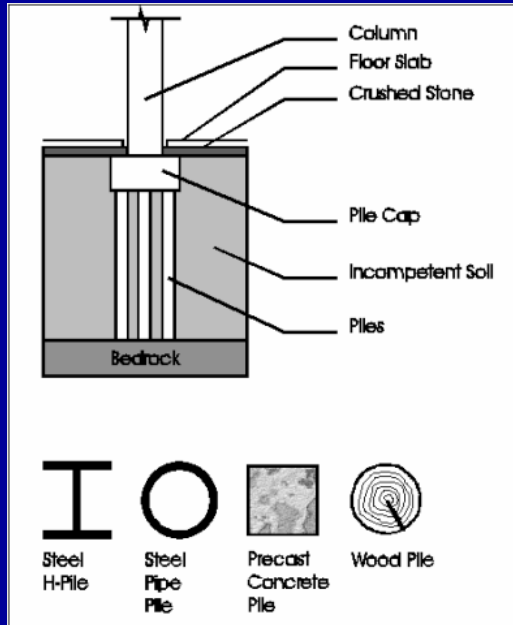

MATERIALS

- **TIMBER**
 - Pressure treated/ submerged
- **STEEL:**
 - H-piles/ Pipe piles
 - Corrosion possible
- **CONCRETE: No corrosion/ economical**
 - Sitecast
 - Precast

DEEP FOUNDATIONS

Pile Driver



DEEP FOUNDATIONS

- CAISSONS
- PILES

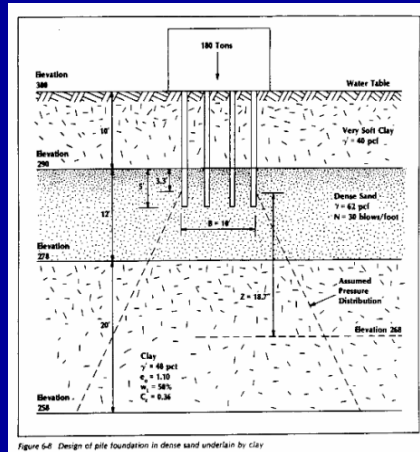

Figure 6-8. Design of pile foundation in dense sand underlain by clay.

DEEP FOUNDATIONS

- CAISSONS
 - Reaches down through layers of unsatisfactory soil until it reaches a satisfactory bearing soil strata



PILES

- A pile is driven into the earth rather than drilled and poured

- **TYPES**

- END BEARING
- FRICTION PILE

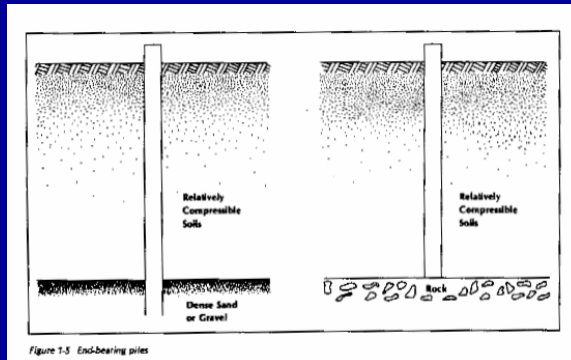

Figure 1-3 End-bearing piles

PILES

- Friction Piles

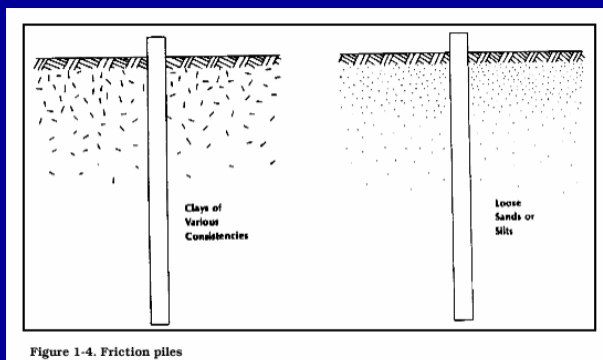

Figure 1-4. Friction piles

PILE LOAD TEST



PILES CLUSTER



CUTTING OFF PILES



FORM WORK FOR PILE CAP



PILE CAP FORMED

- Reinforcing bar extends up to tie into future concrete column



SEISMIC

- BASE ISOLATORS
 - Layers of steel and rubber
 - Lead core
 - Between two steel plates

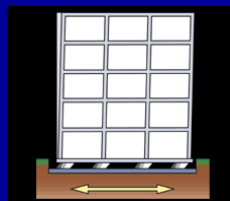
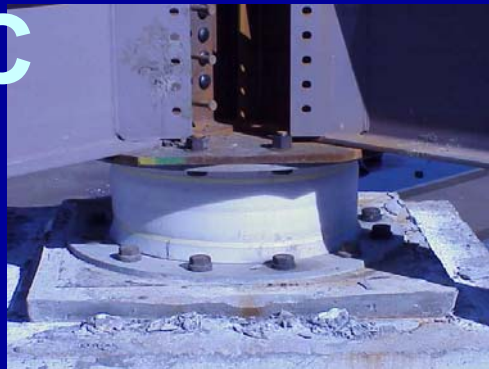

With isolator

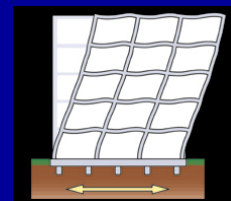

Without isolator

DRAINAGE

- KEEP WATER AWAY FROM FOUNDATION!!
 - Crushed stone
 - Gravel drain
 - Drainage mat or panel
 - Perforated pipe (french drain)

CONCRETE SLAB



CONCRETE SLAB



CONCRETE SLAB

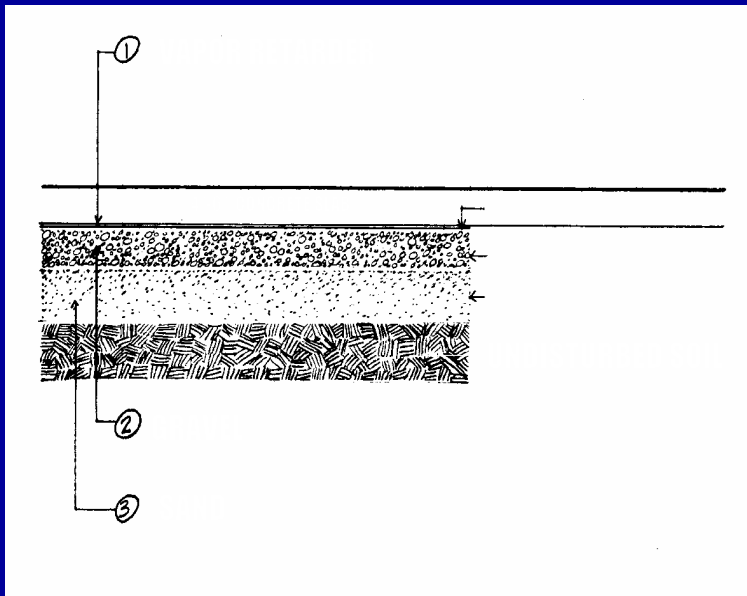

• CONCRETE SLAB

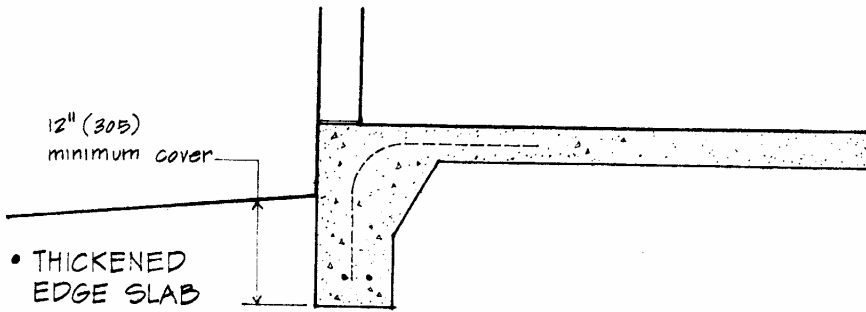

COLUMN FOOTING



FOUNDATION WALL



FOUNDATION WALL

