



JOJAPS

eISSN 2504-8457



Journal Online Jaringan COT POLIPD (JOJAPS)

Design and Fabrication of Eccentric Turning Tools

Khairul Nizam Bin Kamarudin^{a*}

^a Jabatan Kejuruteraan Mekanikal, Politeknik Nilai Negeri Sembilan, Nilai, 71760, Malaysia

Abstract

Eccentric work is a process that is turned off centre, or the centre will offset from the normal centre axis. This process will spent much in setting up the job in a four jaw chuck before turning process can be proceed. This paper presents a tool, Eccentric Turning Tools, ETT for reducing the setup time for eccentric turning in a four jaw chuck and hence productivity is highly increased and high quality of operation is possible. The few operations where been done in CNC Turning and rest operations are carried out in Conventional Machine Tool. The fabricated ETT tools are tested experimentally through 47 novice operators (beginner machinist) and the desired results have been obtained. The findings show that, by using ETT the setup time for eccentric turning are drastically reduced compared to the existing methods up to 90%.

© 2017 Published by JOJAPS Limited.

Key-word: - Eccentric Turning Tools, Four Jaw Chuck, Set-up Time

1. Introduction

Eccentric turning occurs when the work piece axis and spindle axis is in off centre position. Four jaw chucks is most common device that will be used when perform an eccentric turning and this process possesses a set of unique challenges. Cylindrical workpiece has two separate axes of rotation, one being out of centre to the other, the workpiece is termed as eccentric, and the turning of different surfaces of the workpiece is known as eccentric turning. The distance between the axes is known as offset. Eccentric turning may also be done by some special machines. If the offset distance is bigger, the work is held by means of special centres. If the offset between the centres is small, two sets of centres are marked on the faces of the work. The work is held and rotated between each set of centres to machine the eccentric surfaces.

Workpieces are held in lathe with the assistance of chucks, faceplates, or lathe centres. A lathe chuck is a device that exerts pressure on the workpiece to hold it secure to the headstock spindle or tailstock spindle. Commonly used with the lathe are the independent chuck (4 Jaw), the universal scroll chuck (3 Jaw), and the collet chuck. In traditional manufacturing process, performing operation on eccentric shaft is critical. So holding a work piece in proper position during a manufacturing operation fixture is very necessary and important. This is because the shaft is eccentric, so for this requirement of manufacturing process Designer design proper fixture for eccentric shaft. Fixtures reduce operation time and increases productivity and high quality of operation is possible (Shrikant, *et al.*, 2013). In production industries lathe is the very important machine. Particularly for manufacturing shafts, Bushes, Thread, etc., but for eccentric turning, it need s skills to perform the operations (Mukilan, *et al.*2013). Eccentric shaft parts, such as crankshaft, camshaft, have been widely used in manufacturing industries, especially in air-conditioner and automotive industry (Qi Zhang, *et al.*, 2012).

The machining procedure is complex, and it requires the operators to have a high degree of skills, and the process efficiency is low and it could only apply in small batch machining. (Rongqing, *et al.*,2013). There is a set of old-school lathe skills that every machinist, toolmaker and engineer can learn in order to give impact to their effectiveness in handling the machine. For example, machinists should learn to turn an eccentric shape on the lathe.

Eccentric shapes can be made in several ways but are typically made by offsetting the workpiece using a 4-jaw chuck. Learning to master the 4-jaw chuck and understanding how to align parts has direct application on any machine tool with

rotating elements (Christopher, 2015). Experienced individuals will always find ways to save their energy and the time required to do their work. At the same time, they would also worry about the quality of the products that they produced and cost of the product. It is felt that during eccentric turning, a good amount of time is spent in setting up the job in a four jaw chuck. Moreover even for a skilled turner it is a laborious and tedious to set the job for eccentric in a four jaw chuck (Dr G. Naga, *et al.*, 2013).

There are four jaws in this chuck. Each jaw is moved independently by rotating a screw with the help of a chuck key. A particular jaw may be moved according to the shape of the work. Hence this type of chuck can hold woks of irregular shapes. But it requires more time to set the work aligned with the lathe axis. Experienced turners can set the work about the axis quickly (Jayakumar, *et al.*, 2013). In a four jaw chuck, each of the jaws moves independently. The jaws are moved to approximately the dimensions of the part about the centreline, the part is placed in, and each jaw is moved to clamp on the part. A dial indicator is placed in contact with the surface of the segment to be worked on and the chuck is rotated by hand to determine the displacement of the centreline of the segment from the centreline of the chuck. The jaws are then moved independently to align the centrelines, the part re-clamped, and alignment rechecked with the indicator. This may take several iterations and 30 to 40 minutes (William, *et al.*, 2009).

Four-jaw chuck clamping is to go through crossed first two asymmetric regulation when clamping jaws, and then adjust the two symmetrical jaws to process the workpiece; the disadvantages of them are that the spacer needs to accurately calculate the low precision, clamping trouble, difficulties to find a positive, error-prone, cumbersome measurement and detection. Special fixtures targeted, not suitable for a single small batch production, cannot be reused. Solve those problems, designing a fixture to eccentric part and the eccentric turning clamp reset. To solve the problems of the gasket needing to accurately calculate the low precision, clamping trouble, hard to find, easy of producing error, measurement and detection problems; special fixtures targeted, not suitable for a single small batch, and other issues cannot be reused (Ming, *et al.*, 2014).

The reason for in any way considering the use of four jaw chucks in comparison with three jaw chucks is that, with a larger number of jaws which embrace the workpiece, the spot loading on each individual jaw is reduced. Consequently, with a larger number of jaws, the forces which act on the workpiece and which consequently deform the workpiece are more uniformly distributed over the periphery of the workpiece. That increases the dimensional accuracy of the workpiece after machining (Jens Meyer, 2015).

2. Methodology

The study will be based on experimental works starting from the machine construction and followed by processing of the setup time data analysis. Observation on the different method of setup time will be done step by step to clarify the best way to finish the job. The next is the specific steps to be carried out during the study:

- i. Construction and setup of conventional lathe machine with four jaws chuck **Figure 1**.
- ii. Work piece preparation: Marking on work piece is to be done with help of height gauge, cylindrical marking tools, surface plate and a centre punch as shown in **Figure 2**.
- iii. The detailed assemble diagram of Eccentric Turning Tools, ETT as shown in **Figure 3**.
- iv. Practical work based on two method of setup time.
 - a. by using usual methode: Try & Error Methods
 - b. by using ETT.
- v. Time taken to set the job is measured and compared for both methods by using stop watch.



Figure 1 Work piece preparations on lathe machine.

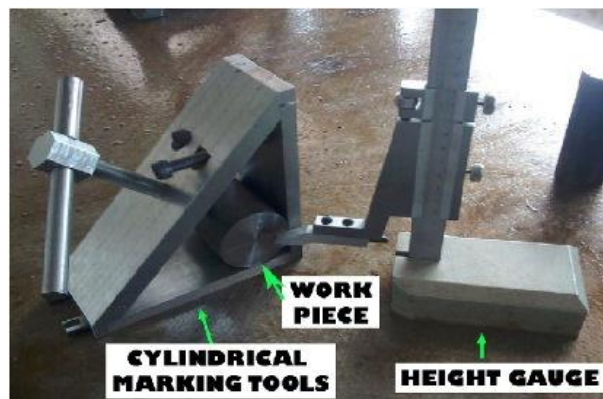

Figure 2 Work piece preparations on surface table.

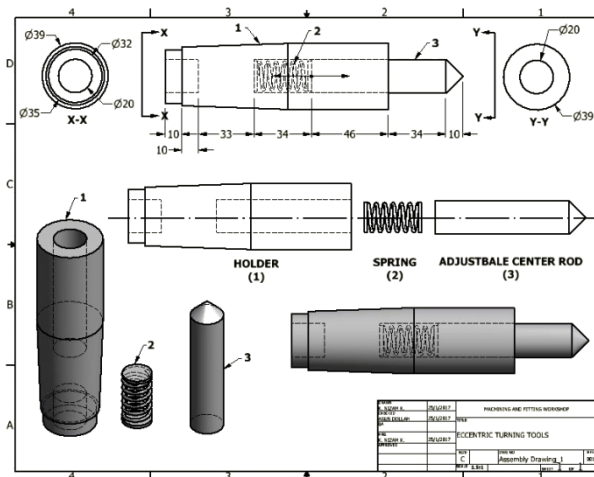

Figure 3 Assembled Diagram of Eccentric Turning Tools, ETT

3. Results and Discussion

This section presents the findings obtained from the analysis of the questionnaires that were distributed to 47 respondents (novice operators) after they complete a job to set up the work piece into the four jaw chuck. The work performed is divided into two methods, which is by using ETT (Job 1) and completed by using existing methods (Job 2). Comparison of setup time between the two methods was measured and recorded to see the differences. The time taken will be categorized into several groups to facilitate comparisons made.

Table 1: Respondent distribution according to number of respondent (*f*) and percentage (%) of the setup time by using usual methode.

No.	Time Taken (minutes)	Number of Respondent (<i>f</i>)	Percentage (%)
1	30	21	44.7
2	35	1	2.1
3	45	1	2.1
4	60	16	34
5	90	1	2.1
6	120	6	12.8
7	180	1	2.1
TOTAL		47	100

From **Table 1**, A total of 21 respondents took 30 minutes (44.7%) to finish the task, 16 (34%) respondents take over 60 minutes and 120 minutes time taken for 6 (12.8%) respondents. While two (4.2%) respondents were recorded 35 minutes and 45 minutes. The findings also showed the longest time taken is 180 minutes, which represents a respondents of 2.1% (1 person).

Table 2: Respondent distribution according to number of respondent (*f*) and percentage (%) of the setup time by using ETT.

No.	Time Taken (minutes)	Number of Respondent (<i>f</i>)	Percentage (%)
1	3	4	8.5
2	5	29	61.7
3	7	3	6.4
4	10	11	23.4
TOTAL		47	100

From **Table 2**, A total of 11 respondents took 10 minutes (23.4%) to finish the task, 3 (6.4%) respondents take over 7 minutes and 5 minutes of time taken for 29 (61.7%) respondents, which is more than half of total respondents. The study also recorded that the fastest time taken is about 3 minutes, which is represents 4 (8.5%) respondents. There are significant differences that can be seen from the result of ETT usage compared with existing methods. In just three minutes, by using ETT the task has been complete compared with the existing methods, which is 30 minutes. A very significant different, which is up to 90%. The findings also show that, the maximum time needed by using ETT is 10 minutes compared to 180 minutes for the existing methods, a difference of 94%. The average time for the ETT is 6 minutes and for the usual method is 80 minutes, a difference of 93%.

Basically the use of time is directly proportional to the energy consumption of operators in conducting and carrying out the activity. The longer the time allocated for a particular job or process to be completed, the more energy will be used. This indicates that the time factor is the most important factor and is a matter that should be given serious attention. Apart from the time factor, there are many other factors that were taken into account in producing the ETT. There are several improvements and modifications that have been made in producing ETT based on problems that have been encountered and from the results obtained such as the tools are more economical in term of cost, the tools are simple in application, the tools are simple in fabrication, novice operator can set the job efficiently and perform the work, small in size compared to existing tools, it requires no external power source for movement, no expensive material is necessary to construct the tools, no special manufacturing methods are necessary to manufacture the tools and more important is setting time is drastically reduced when compared with existing methods (Figure 4). There are some constraints and problems faced by the operator when using existing methods such as a lot of time used for the preparation of the workpiece, the operator used a lot of energy to setup the work piece on four jaw chucks, novice operators struggled to finish the setting, the dimensional of the workpiece is less accurate, a lot of tools will be used along the setting up the work piece and required long preparation step.



i. Scale Methods



ii. Dual 'T Spanner'

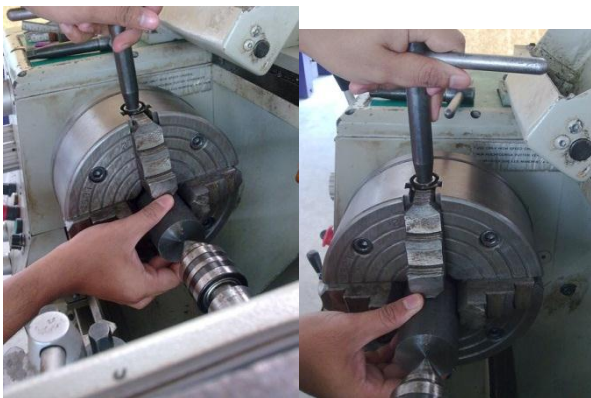

iii. Try & Error Methods



iv. Dial Gauge Methods

Figure 4 Existing methods in eccentric turning.

4. Conclusion

The benefits and advantages by using eccentric turning tools as compared to the existing methods are drastic reduction in setup time, the minimum time taken to set the job by using ETT is 3 minutes compared to existing method, which is 30 minutes, that is 27 minutes (90%) reduction is achieved. For maximum time taken by using ETT is 10 minutes compared to existing method 90 minutes, reduction in setup time about 88.89% (80 minutes). Novice operators can also perform eccentrics turning by setting the job quickly and easily with the help of eccentric turning tools. With four steps of eccentric turning tools setup do not required any extra tools to operate it when compared with other lathe fixture or jig. The main materials are using to fabricated the tools is low carbon steel (mild steel) which is inexpensive types of materials and easy to find and get in open market. In production, high productivity especially in small medium industries can be easily achieved. The finish product that produced by using ETT, much more accurate in term of dimension tolerance.

For the maintenance, the tools only required cleaning and oiling. For the future, improvement of tools can be made in term of tips of tools (harden the tips until the physical properties turn to be more hard than original properties). Suggestion weight of work piece is less than 10kg because of the raw materials will be handling by operator himself alone.

The successful running of all over mass production depends upon the interchange ability to facilitate easy to assembly and reduction of unit cost. There is a necessary of special purpose tools which are used to facilitate the production operation like as machining, assembling, intersecting, etc. (Nanthakumar, *et al.* 2014). Fixtures reduce operation time and increases productivity and high quality of operation is possible (Shailesh, *et al.* 2014). According to Dr G. Naga, *et al.* (2013), the important benefits of using the eccentric turning attachment as compared to the usual methods are by using Eccentric Turning Attachment (ETA) are drastic reduction in setup time. Therefore a simple and easy to operate tools has been designed, “Eccentric Turning Tools (ETT)” which will reduce setup time of workpiece for eccentric turning in a four jaw chuck.

5. References

- Christopher Tate-Mastering Basic Turning Skills - Dec(2015). Shop Technology. Retrieved from <http://www.ctemag.com/cteguide.com>
- Dr G. Naga Malleshwar Rao, Dr S.L.V.Prasad, P. Sreenivasulu (2013). Design and Fabrication of Eccentric Turning Attachment. International Journal of Application or Innovation in Engineering & Management (IJAIEEM), Volume 2, Issue 8, 199-202.
- G. Jayakumar Jesudoss - General Machinist Theory (First Edition) (2011). Tamil Nadu Textbook Corporation. Retrieved from <http://www.textbooksonline.tn.nic.in/std12.htm>
- Jens Meyer (2015), Compensating Chuck. IFI CLAIMS® Patent Services, Retrieved from <https://www.google.com/patents/US20150352642>
- K. Nanthakumar and V. Prabakaran (2014), Design and Fabrication Testing of Combined Multipurpose Jig and Fixture. Journal of Mechanical and Civil Engineering, Volume 2, Issue 2, 126-146.
- Ming Yao Wang (2014), Accurate and reset turning eccentric eccentric fixture developed parts. Advanced Materials Research, Vols. 971-973, 329-332.
- Mukilan. B, Karthikeyan S dan Gowtham.G (2013), Design and Fabrication of Lathe Fixture For Eccentric Operation. Journal of Science and Innovative Engineering & Technology Automobile & Mechanical, Retrieved from www.ijset.org/am_14/1_26_am.pdf
- Qi Zhang, Chundong Wu dan Shengdun Zhao (2012), Less Loading Tube-Hydroforming Technology on Eccentric Shaft Part by Using Movable Die. Materials Transactions, Vol. 53, No. 5, 820-825.
- Rongqing Liang, Jinling Cong, Jindong Sun, Za Kan, Chengsong Li dan Fengjin Sun (2013), Design of Machining Fixture for Thin-walled and Eccentric Parts. *Applied Mechanics and Materials*, Vols. 278-280, 261-266.
- Shailesh S.Pachbhai and Laukik P.Raut (2014), A Review on Design of Fixtures. International Journal of Engineering Research and General Science, Volume 2, Issue 2, 126-146.
- Shrikant.V.Peshatwar dan L.P Raut (2013), Design and Development of Fixture for eccentric shaft: A Review. International Journal of Engineering Research and Applications (IJERA), Vol. 3, Issue 1, 1591-1596.
- William Shrikant. Wachtler and John C. Read (2009), Chuck jaw with adjustable tooth. IFI CLAIMS® Patent Services, Retrieved from <https://www.google.com/patents/US7537218>.