

Goddess image as the rebirth of the Soul or Higher Self

THE KEYS TO KABBALAH

Alan Bain

© Alan Bain 1970 through 2003

Part one

Preface to Alan Bain's *Keys to Kabbalah* (April, 1997)

It was with great pleasure that I announced the appearance of the electronic version of Dr. Alan Bain's book "**The Keys to Kabbalah**". His book has circulated in a limited circle of students thus far, one of the reasons being the non-sensational approach of the author respecting Kabbalah.

The teachings of the Kabbalah form an integral part of the so-called Hermetic tradition (encompassing areas of study such as Kabbalah, tarot, alchemy, astrology, etc.). This tradition has long been an influential factor behind the scenes in Western civilization and is currently gaining ground and getting the attention it deserves.

It seemed a good idea to me to make Dr. Bain's research on the Kaballah available to the student in this field, especially since his work contains valuable new insights pertaining to the tree of life in relation to the 21 stages and 32 paths of wisdom, culminating in his diagram called "**Jacob's ladder**".

The old Kabbalistic doctrine of emanations is clearly illustrated in this diagram and elaborated upon in the text. Also, this book may provide a key to you for charting your own progress on the spiritual path.

Dr. Alan Bain has studied, taught, and practiced Kabbalistic teachings for over thirty years and has consented to my request to publish his book on the world wide web. He was also one of the founders of an organization that promoted the study, comparison, and practice of the various esoteric teachings and traditions that currently exist in this world.

One of these practices is to rephrase old ideas from the wisdom-tradition (known under various names) into modern language and concepts. It is my hope that the students of ~Keys to Kabbalah~ will be able to expand their understanding of Kaballah, of matters of the spirit, through a serious study of Dr. Bain's book. They may in the long run be able to contribute themselves to the body of knowledge that is offered here.

Martin Euser

INTRODUCTION

THE TEN SEPHIROTH

As is known to many students of Kabbalah, much of the information available dealing with the theory of the subject has been derived, in some cases through two or three generations, from various works published by members, or sometime members, of The Hermetic Order of the Golden Dawn. The teachings derived from this source have helped many students to understand human nature and their relationship with the spiritual dimension.

Much of this teaching included deliberate "mysteries" which led many students to believe that some areas are for ever beyond human knowledge. As far back as the late Nineteen-fifties, it became clear that the subject was misrepresented. This was because, as well as the "mysteries" mentioned, the teaching incorporated inconsistencies which led naturally to conclusions not borne out by experience.

This inspired looking more deeply into the matter, and the results of over forty years of work are now freely available. Originally completed in 1970, this work has circulated mostly to a few students in sections and in manuscript form, partly for lack of funds, and partly due to the reluctance of publishers to move away from the tried and tested "safe" - and usually "sensational" type of work (such as "How to make your numbers and stars work for you improve your love/sex life make you rich and able to live forever in your astral body without having to leave this one that will remain forever young send \$25 per jar.")

As a basis for research, it was necessary to go back to what are believed to be the first published writings on the subject, namely the *Sepher Yetzirah* (or Book of Formation) and the text known as the *Thirty-two Paths of Wisdom*. From these beginnings, it has been possible to build up a consistent scheme which does not incorporate an embarrassing number of "mysteries" and which can be verified by personal experience. Because there are readers who are being introduced to Kabbalah for the first time in these pages, it is necessary to start at the beginning with some elementary definitions familiar to students of any school of Kabbalah. The differences in the arrangement presented later will not, therefore, become apparent until these preliminaries have been disposed of. From that point on, however, it will be found that the teaching progresses naturally into areas which have previously been considered enigmatic or paradoxical and thence to an exposition of "Jacob's Ladder" (*Genesis*) which not only incorporates "ten

Sephiroth and not nine, ten and not eleven" (*Sepher Yetzirah*) but also consists of thirty-two paths (*32 Paths of Wisdom*) with no serious inconsistencies or paradoxes whatever.

The keys to the Holy Kabbalah, a path of Knowledge, Wisdom and Understanding, lie in the texts already mentioned, *The Thirty Two Paths of Wisdom* and *Sepher Yetzirah*. A most serviceable translation of the former is made by A.E. Waite in his book *The Holy Kabbalah*, and this version is used here in conjunction with the text of *Sepher Yetzirah*. In the diagram of the Ladder delineated in Part Three, these thirty two paths are presented according to the principle of a "lightning flash" and in doing so reveal ten Sephiroth. "Ten and not nine; ten and not eleven." At the same time, the Tree of Life is unfolded in each of the four Worlds of Kabbalah, preceded by three veils of "negative existence" and culminating in the Malkuth of Assiah. With the keys now in place, the diagram of the Ladder becomes a mine of Kabbalistic information and is, at the same time, a complete exposition of Kabbalist teaching.

For those whose understanding of the subject is small, there is an introduction to the basic general principles of Kabbalah and its root doctrine of the ten Sephiroth.

Attributions of the Tarot

In Parts Two and Three, there is frequent reference to the 22 "Trumps" of the Tarot. Such attributions as have been used have not been included in all of the diagrams. This is because they can be used on at least three levels, and the simplicity of diagrams would become unnecessarily complicated by the addition of too many texts, figures, numbers and the like. For reference purposes, all attributions, of which the Tarot is a major source, are tabulated at the end of the series, apart from those found illustrating the twenty one stages of the Way, included in Part Two. The Tarot illustrations in Part Three are from a primitive source much older than those used in Part Two, and help to explain why two cards re-numbered by Waite have had the original numbering restored.

On the use of Tarot cards generally, two things need to be said. First, their main value lies in their being an aid to understanding. They have no intrinsic merit in themselves. The mystique of the cards lies only in their ability to arouse a response in the observer. In themselves, they are pieces of card with pictures on them. As an aid to understanding, it is the picture which is important. The titles commonly given to, or found on the cards are principally for convenience as a means of identification. Early packs have no such titles (as is seen in the Part Three illustrations).

START HERE ...

The word Kabbalah is derived from a Hebrew word meaning "to receive," and Kabbalah is a teaching received. Its origins, like other similar doctrines, are obscure. It is enough for our purpose to say that its first outward appearance seems to have occurred during the twelfth and thirteenth centuries. Since then, a tremendous amount of superstructure has reared itself upon the Teaching from Christians, mystics, astrologers and the like. This can only be tested by study and experience. We are therefore compelled to take it as we find, and to test its validity for ourselves. It is not essential [though interesting] to establish origins, for if what we are taught makes sense in terms of our experience, then for us it is valid until further experience either confirms or denies it. Therefore, Kabbalah is given here as received, without placing unnecessary emphasis on 'from whom' or from where.

Kabbalah seeks to lead to Self knowledge among those who use it. It attempts to provide answers to the riddles of the universe and the riddles of humanity. This it does, in part, by likening the one to the other" saying, "that which is above is like unto that which is below." In terms of the "above," it sets forth a description of the basic laws of the world or the universe, and works its way, step by step, to individual human beings and their various states of awareness. It is a comprehensive system, and is so constructed that it can readily absorb into itself other teachings and philosophies without losing anything of its own character. In fact it gains from this.

The Tree of Life

The basis of Kabbalah is a diagram called the Tree of Life. It consists of a representation of ten spheres or regions systematically arranged to illustrate the patterns and relationships of things. The most important thing about this diagram is that it illustrates the doctrine of emanations, by which each sphere emanates its successor, without losing anything of itself, so that the first sphere is said to contain all those below it in order of creation. Similarly, it is said that the last sphere contains all those above it in the order of creation.

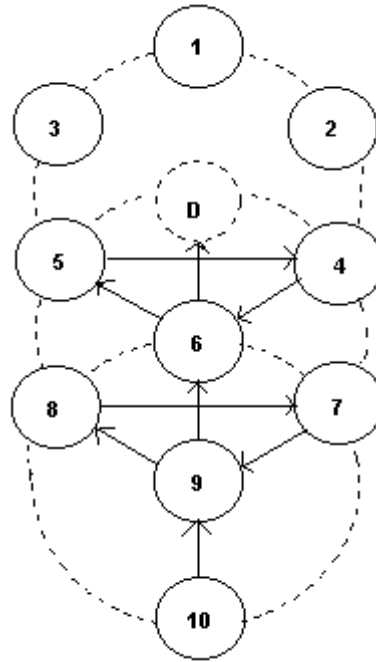

These ten spheres are called the ten Sephiroth, a Hebrew word meaning numbers, or better, numerations, the singular of which is Sephira.

The first Sephira is called Kether, which means Crown, and may be considered as representative of the Infinite Source of all things. From the activity of this source emanates 'Hokma, Wisdom, which, while being a separate sphere, is nonetheless still part of Kether; and Kether, although having emanated 'Hokma, has lost nothing of itself. 'Hokma in turn emanates Binah, Understanding, which in turn causes to be emanated 'Hesed, Mercy; Geburah, Strength; Tiphareth, Beauty; Netzach, Victory; Hod, Glory; Yesod, Foundation; and Malkuth, Kingdom.

Kabbalah is a Hebrew teaching which has been developed and expanded by Christians and others. The important thing, however, is not how it has developed but what it is capable of bringing to its students. It is suited particularly for those seeking an increase of awareness, Self-knowledge and Self-realisation.

The Four Worlds

The ten Sephiroth exist in what are called Four Worlds. This means that Kabbalah distinguishes between four states of being, from the most abstract and spiritual to the most dense and material. Rather like the Sephiroth, the Four Worlds depend from each other, but in a different manner. The first of the Four Worlds or levels is called Atziluth, or the World of Emanation. Here, creative force is seeking expression, but lacks form. In Atziluth, the Divine Source takes the first steps towards creation. If we think of this in terms of the creation of the world, then drawing a parallel with Genesis we can say:

"In the beginning the Earth was without form and void, and darkness was upon the face of the deep. And the Spirit of God (or "gods") moved upon the face of the waters."

Atziluth, then, is pure spirit beginning to take its first movements towards creative expression. It is that region where all potential lies, from where may come anything we may learn how to bring into expression, or that may be brought into expression by divine activity or "Holy Spirit." In Kabbalah, we try to make our actions and operations come into line with this divine activity, or LAW.

The next World in order is called Briah, and is described as the World of Creation. It is the region where the basic plans for the objects of creation have their beginning. From Genesis again:

"And God said 'Let there be light,' and there was light. And God saw the light that it was good; and God divided the light from the darkness."

If there were no light or darkness we should be unable to perceive anything, whether of light we measure in wavelengths, or of spiritual light when the word is used another way. In Briah are the seeds -

and only the seeds - of differentiation. In terms of human psychology, here lie the roots of mind, the raw material from which ideas and ideals are born.

It is not until we reach the World of Yetzirah, or the World of Formation, that form, produced through force, begins to take on recognisable shape. In this region, everything that takes place can present an image to the mind. Symbols, as distinct from the words which describe them, are of great value, for they can convey concepts which, if we tried to think about them in an ordinary sequential manner might take days to formulate. An excellent example of this is the Tree of Life itself. It makes no difference whether an image invoked in the mind is of an object, perhaps remembered, or if it is pure fantasy. For this reason Yetzirah, where in human terms, all is seen in the form of image and symbol, is the most dangerous of the Four Worlds, for here fantasy can seem as real as the record of facts held in the memory.

To complicate matters, it is at this level that we mostly “live and move and have our being” in real terms: another way of saying that we spend most of our waking lives in a perpetual round of fantasies and mental imaginings, often hardly noticing our physical surroundings at all. This will help explain why, in Christian terminology, the world of Yetzirah equates with Purgatory - not a place to which we go after death to be “punished” for our crimes, but a world in which we live right now, and in which we need to “purge” or purify our lives. It is in this world that most of the work of the Kabbalist takes effect.

Kabbalah helps us to distinguish between that which is real and that which is not. From there we can begin to build a real place for ourselves in a real world, and to become real people.

The last of the four Worlds is called Assiah, the material world, related to the *Klippoth*, or shells. In Assiah, all the activity of the previous three Worlds finds its expression in material activity, or material objects. It is also the world of appearances, for all things in Assiah contain within them the three worlds preceding it, hence the idea of shells, or containers. *That includes us*. It is Assiah with which we are necessarily the most familiar, and in which we seek to create order. We often fail in this, since for there to be order in Assiah, it must first be conceived in Atziluth. In other words, there can be no harmony in the world unless we recognise therein the activity of the divine influence, the Holy Spirit, or presence of ‘God’ - YHWH (יהוה) - “That-which-is,” or “Eternal Being.”

1. KETHER (Crown) כתר

There is little that can be said about Kether, for according to tradition, those who reach it do not return to tell us of their experience. Kether is, for us, unknowable, but we may nevertheless speculate concerning it, and we may attempt to describe it by saying what it is not. Kether is Eternity, an idea expressed by its other titles, The Ancient of Ancients, the Ages of Ages and the Ancient of Days. We are accustomed to think of eternity as an infinite extension of time. Eternity, as symbolised by Kether, is the complete absence of time. In Kether, time is not.

Kether also represents the goal of all things. Time, like the things of life, is an illusion; a reflection. Any spiritual condition of the nature of Kether is impossible of realisation in our earthly existence. While we are in the body, we are subject to, and limited by, time. To exist and function in Kether, we should need a form - or lack of one - where the conditions of time did not apply. There are, however, in various ways, conditions which approximate to Kether. To explain this, it is necessary to introduce the idea of scale. It is possible to draw the Tree of Life in such a way as to give a separate Tree in each of the Four Worlds (which is seen in the breakdown of the Ladder in Part Three). Because of variations at different levels, it is essential to distinguish in the mind upon which scale we are working, and not to mix one with another, except insofar as “that which is above is like unto that which is below.” (Like unto it - *not the same* as it). If we attempt to compare the attributes of Kether on different scales, there may be, at first glance, little that seems to connect them. At one end of the scale is the Ancient of Days - a description of YHWH, or ‘God’. Further down the scale we find the divine spark in each human being. Both concepts may be referred to Kether. The Ancient of Days is like a remote and elevated deity who has the power of life and death over not only humans, but over whole worlds, galaxies, or even the Universe in its entirety, whatever that may be.

The divine spark in ourselves, which can be described as the purest part of our being, is the factor which makes us human. Without it we are governed entirely by sense experience. It may seem that there are many people who are exactly like this. How closely do we, as individual human beings, stand examination? What makes us so special if we have no such divine spark? The answer is that we do, but are not necessarily aware of its existence. Kabbalah teaches that whilst in human form we may learn that we *are* so endowed, and to grow and develop by learning to bring the activity of Yechidah, or spirit, into the experience of life, discovering self-knowledge and self-realisation as we do so.

A little thought shows that the two correspondences given have something very basic in common. Without the “Ancient of Days” the world could not exist. And without the divine spark in ourselves, we,

as we are, could not exist. Consider that the search for self-realisation is in three stages, which can be described as:

1. Know Yourself. 2. Understand Yourself. 3. Be Yourself.

In the sense that these terms are used, it would be foolish to assume that we have necessarily begun to do even the first of these, although it is a good thing to attempt to be ourselves always, as best we may. Most people seem to be dominated by one of the four psychological functions described by Jung: Thinking, Feeling, Sensation and Intuition. If we are to break the ties which bind, we must set our sights upon Kether, not some intermediate stage, for those who wish to fly to the moon cannot hope to succeed if they make their calculations for a point somewhere along the way. It is in this light that we need to approach the study of Kabbalah if our study is to be practical, and this light is a spiritual one. Kether represents the Holy of Holies, whatever this expression may mean to whoever uses it, for which reason one Kabbalistic organization exhorted its members not to blaspheme the name by which others know their god. No matter what our level of understanding, or from what level we approach, there is always a Kether which for us is unattainable. In any theology, God is necessarily omnipotent and omniscient, for God is always the Crown of Creation, Kether, which, in the words of Path Ten of the 32 Paths of Wisdom, "is exalted above every head" (as the Kether of the World of Briah).

2. 'HOKMA (Wisdom) חכמה

In 'Hokma, the source of all being in Kether has begun to move in the direction of manifestation. As with Kether, there is not much we can say concerning this sphere except by analogy. Let us consider, if we can, infinite power in infinite motion in infinite space. This may give some idea of the nature of 'Hokma. Also, we need to remember that at this level there is no such thing as time, for the conditions of limitation necessary for its existence have yet to appear. 'Hokma is undifferentiated force, whereas Kether is undifferentiated potential. In 'Hokma, this potential begins to move, begins to be realised, but unless it is limited in some way, unless it can be circumscribed or contained, nothing may be created, nothing will become manifest. A good analogy for 'Hokma is electrical energy. While much is known about this force, all that we know is known only because we are able to trap its energy by various means. We know, for example, that radio waves are carried continuously through the air, but we are unable to make use of them unless we are able to build an instrument to confine them and to channel them in a way that may be of service, as we do with a radio receiver. In a sense, then, although we may consider 'Hokma as total power in total motion, this power is equally impotent, because being infinitely distributed through eternal infinity, its pressure is equal in all directions

We can get a glimpse of the significance of 'Hokma when we regard it as the "Supernal Father," as it is sometimes called, or a fundamental male principle. In doing so, we shall see how analogies with human sexuality are useful in understanding the mysteries of Kabbalah. The human male is in a similar position to 'Hokma, for like the Sefhira, he bears within him the seeds that may beget life, but if this seed is dispersed outside the body, then no life form can be created. The human male seed has to be contained within the human female and combined with her seed. Even then, many further processes are necessary before there can be a human child. Analogously, the energy potential of the Supernal Father has to be contained within the Supernal Mother, Binah, before creation proper can commence; equally, there are further processes to be undergone before this creation can become manifest, before the spiritual child is born. Here, as with all the Sephiroth, we can see a universal Law of being applying to all things at all levels, from galaxies to geraniums.

3. BINAH (Understanding) בינה

When we reach the Sefhira Binah, we begin to be in a position to describe some recognisable conditions, although we are still dealing with basic principles. One of the symbols for Kether is the point, which in pure mathematics has no dimension. A similar symbol for 'Hokma is the straight line, which has length but no width. The relevant symbol for Binah is the triangle, and here we can see via the symbolism that the impulse towards creation begins to be confined, in the same way as the space within the triangle is confined.

Binah has been called the Supernal Mother, and we can see how this principle complements and balances the operation of the Supernal Father, 'Hokma. We can also see that the analogies with human sexuality mentioned when describing 'Hokma are in accord with the symbolism. In Binah we are getting closer to principles which we can understand in a more material sense. Indeed, this Sefhira has strong associations with the tenth Sefhira, Malkuth, which represents the manifest creation as we see it.

The principle that is Binah, Understanding, is the principle in everything at all levels which confines and contains within definite limits, as the space is confined within the three sides of the triangle. Hence the title, Understanding, for to understand anything we must be able to contain it within some frame of reference. Understanding is made up of two words, "standing" and "under." In this sense, Binah stands under the two Sefhiroth preceding it, and receives from them the influence which it is able to contain, confine, and preserve. In astrology, Binah is associated with the planet Saturn, which has similar attributes.

We can see how Binah acts like a receptacle for the energies of the other two Supernal Sefhiroth. There is a relationship here with the ninth Sefhira, Yesod, Foundation, also called "the receptacle of the emanations" due to its position on the Tree of Life. In this illustration we can also see that each Sefhira below Kether is thus the source from which the Sefhiroth below it are brought into being. This is even true of Kether itself, for it is condensed from out of the non-substance of the Great Unmanifest, and is itself subject to the law of emanation. Binah as Supernal Mother, the Great Mother of ancient religion and modern depth psychology alike means that for immediate practical purposes it represents the highest level of principle that we, as incarnate human beings, may appreciate. Binah, though, is on the far side of an Abyss, and we can therefore never fully realise the nature of this Sefhira while in the flesh. Fortunately, we are nonetheless able to make some contact with this level at advanced stages of practical work by virtue of the link which arises between the Supernal Sefhiroth on the Tree of Life and those below them. This link is called *Daath*, Knowledge, sometimes considered for convenience as another, "invisible" Sefhira, more properly explained elsewhere. Here we may simply say that Daath, as a Sefhira, does not exist. The path of the Lightning flash proceeds directly from Binah to 'Hesed, the fourth Sefhira, without interruption in its journey. As Daath is sometimes portrayed in the centre of the Abyss, we shall describe the significance of Daath before going on to the remaining Sefhiroth in the order of their emanation. (Daath is shown as the dotted circle in the diagram of the Tree)

DAATH (Knowledge) דעת

Daath cannot in any sense be considered as a Sefhira on the Tree of Life. It does not emanate from any other, nor does it cause anything to be emanated in its turn. Its significance lies in the position assigned to it. Daath means knowledge, and has significance only as a function of consciousness - but it is present only to consciousness developing upwards towards the higher principles. On a different scale, it is the point of contact between those who work within the world of appearances - in groups and societies for example - and what has been described as the "inner planes." This term can be misleading, but so can any terminology which seeks to describe the non-material aspects of creation, of life, being, and consciousness itself. That there is a reality to these "inner planes," is beyond reasonable doubt to those with sufficient experience, but it is no kind of reality or objectivity as we are accustomed to experience it. Not a great deal can be said about Daath at this point, except that it is the point of knowledge via which hidden teachings are received. It may for practical purposes be considered as a function of the Sefhira Tiphareth, and yet has many Binah qualities and attributes. At the same time, it is the Throne of Binah to the developing consciousness. It is best understood in the light of the "subjective" Sefhiroth in connection with the Ladder in Part Three.

4. 'HESED (Mercy) חסד

The fourth Sefhira is the highest level we can ordinarily reach without special disciplines. The planet Jupiter is assigned to this sphere. In astrology, it is the planet governing religion and philosophy. For our study, more is required than ordinary religion or philosophy can provide. In its representation of basic principles, 'Hesed refers to the very beginnings of manifestation that we can knowingly understand. The triangle of Binah has no depth, and cannot therefore symbolise anything properly material, being only two-dimensional, whereas creation as we see it is three-dimensional. In 'Hesed we can add an apex above the triangle, forming a triangular pyramid illustrating the possibility of movement within space as we

understand such movement. In so doing we have also introduced time and duration. Here we have the ground plan of creation made manifest. Here lie the roots of nature and of natural law. 'Hesed is the principle from which these roots and this law derive their origin. If we consider the triangular based pyramid as made of glass, like a bottle, but with no opening, we can imagine that the bottle fills with water, but from within itself, in a way we cannot fathom, due to the influence of the three preceding Sephiroth, by way of emanation. The principle of limitation established in Binah is now at work, for the bottle can only contain as much water as its form allows. At this level, however, we are still dealing very much with abstract principles of emanation, later to become manifest in Malkuth. Our bottle's dimensions are still those of infinity. Within this bottle only is there such a thing as time, as we understand time, and it is within this bottle that all life subject to limitation has its origin and its being. The bottle that is 'Hesed is of infinite size, and of infinite duration. (Usually rendered "Mercy," 'Hesed can also mean "Benevolence" and "Charity, or "Love.")

5. GEBURAH (Strength) גבורה

This principle may be considered as the force which motivates to activity. It is not the activity itself, but the power which lies behind it. In 'Hokma we described the principle of undifferentiated energy. Here, that energy has been confined by the third Sephira Binah, and transformed into potential by the additional dimension developed by 'Hesed. In Geburah energy is set in motion subject to the limits imposed by the principles emanated before itself. If we consider the analogy of a car engine, we can obtain an idea of the importance of Geburah. The idea of being, i.e., that there can be such a thing as the engine, stems from Kether. The potential to drive it derives from 'Hokma. The principle of confining this energy to put it to practical use is provided by Binah, and the idea of the form it will take is established in 'Hesed. Geburah represents the principle of this energy in controlled motion, motion controlled by the activity of four principles. It does not in any way refer to the means of operating the engine, such as the fuel, or the spark which ignites it. It is the principle which contains the necessary energy to drive the car. The mechanics come later. Geburah represents the principle of energy in controlled motion for particular purposes, whatever they may be. Therefore the principle that we call Geburah, Strength, is true for such motion at all levels, whether it be the car engine, the revolution of the world on its axis, the power behind galactic motion or that behind human desires, all of which by virtue of Geburah are driven to perform varying kinds of activity. In astrology it is referred to Mars, the god of war - very much a business of controlled energy, with its creation of armies, weapons, and the means of delivering that energy for particular purposes, to particular targets.

Geburah is the throbbing at the heart of all things that are.

6. TIPHARETH (Beauty) תפארת

This Sephira is, for us, the most significant on the Tree of Life, and one of the most difficult to describe. In astrology it is represented by the Sun, the centre of our own solar system, and Tiphareth may be regarded as the centre which holds the other Sephiroth together in a similar manner. In Tiphareth all conflict may be reconciled, all seeming contradictions resolved. Tiphareth is the principle of manifest being. To avoid confusion, we must remember that it is *manifest* being which is being referred to; absolute being is a quality of Kether and the unmanifest which precedes it. Without Tiphareth, all the principles of form and energy which have gone before can come to nothing. The knowledge of force and the understanding of form cannot of themselves cause anything to become manifest in creation. In order for there to be knowledge there has to be one who may know; for understanding, one who may understand. There has to be finite being. Tiphareth represents the principle of manifest being itself, at all levels, be it the individual human being, about whom we understand so little, the being at the centre of the universe, or at the heart of the pebbles on a beach. Tiphareth is the heart of all true religion, for it is the lower representative of Eternal Being, the life of which flows like a cool stream through all that lives. If Kether is God unmanifest, Tiphareth is God manifest. In us it is the individual soul, also called the Self. Tiphareth is the soul of all things. Kether is the Spirit of all things, and Yesod, the Foundation, together with Malkuth, the tenth and final Sephira, representing the outward appearance, is the body of all things.

7. NETZACH ("Victory") נצח

In 'Hesed we considered the ground plan of creation; in this Sephira we are concerned with the principles which enable the plan to take particular forms, according to the functions of the different departments of manifest creation. Where the Sephiroth including and above Tiphareth relate in each instance to one principle or law, those below Tiphareth all have to do with these same principles engaged

in diversification of activity. If we think of 'Hesed in terms of our own world, then the ground plan of this will consist of many things whose existence, or potential existence, is implicit in that plan. Netzach is immediately below 'Hesed on the composite Tree of Life, and may be considered as a reflection of it. In Netzach, the principle is one which separates out the various elements in the ground plan and prepares them for actively manifesting the forms of life. In the human being this principle is related to our feelings about things, people and situations. Observation of our own experience will show that our feelings act in just such a manner, and perform just such a function. There is a continuous sequence of activity in each of us which does not cease from birth to death, waking or sleeping. We are not normally aware of this nor do we need to be, except at such times as we need to understand what we are, and how we work.

In astrology it is related to the planet Venus, and our first reaction to any situation or event is a feeling one. That is to say that our feelings are aroused - or not, which is the other side of the same coin. Feelings stimulate thoughts, and thoughts motivate action, which changes the circumstances. To these changed circumstances we then react with suitably modified feelings, and so the process continues, even in dreams. We may see that there is a constant diversification and adjustment taking place within us that is related to our desires and ambitions. The Sefhira Netzach represents this principle at several levels - diversification and adjustment based on whatever ground plan is appropriate to the level of action concerned. Some Kabbalists have described Netzach as a Sefhira of repetition, a view which expresses well the circular nature of the inner human activity just described.

8. HOD ("Glory") הוד

The diversification spoken of in connection with Netzach is a process which continues and becomes more refined in the Sefhira Hod. Here differentiation is taken a stage further into classification and arrangement. Most important of all is that with the development of this principle the separate, differentiated parts of the manifestation of spirit originating in Kether begin to become autonomous. In Hod they are given the vital energies, as distinct from the principle of energy in Geburah, which are appropriate to, and necessary for them to become finally expressed in Malkuth, the Kingdom, as distinct forms different from each other, although each according to its type, or ground plan. This is so whether that form be animate or inanimate. When parts of a fundamental unity become separated in this way, the only manner by which they may each recognise or rediscover their common origin is by some form of communication of one part with another. At the same time as the principle of Hod separates and gives life, so necessarily does it provide a means of communication between the parts, establishing potential relationships for all forms of life, one with another, as well as with the common life which is the heritage of them all. In astrology it is represented by the planet Mercury.

9. YESOD (Foundation) יסוד

Yesod is the principle which represents in the downward development of the Tree of Life the foundation of all forms of manifest life. It is the principle of body. All forms of life are contained within a particular type of form according to their natures, and Yesod is the principle of this form-giving quality. It is not the body of things as we are accustomed to seeing them, as all we ever see ordinarily is the outward appearance of that body, the surface of it. Yesod represents the totality of body, from the smallest atom outwards. For the same reason, it also represents the motivating principle immediately behind all activity, and like the body, is a continual reservoir of potential motion and action, awaiting only the necessary stimulus. The principle of Yesod is, of itself, inert, and does not initiate anything, being an entirely self-contained principle devoted to maintaining a condition appropriate to the particular form, the particular type of body, so that when it is required to be active in some way it is ready so to behave. We may think of it as a highly present, differentiated principle, localised in each particular form of life, containing within itself all the necessary potential for behaviour and activity inherent in all the principles that have gone before. Vibrant with energy, very much alive, it is prepared for whatever is required. In the human being it governs the action of reflex, whether automatic bodily reflex, or conditioned reflex installed through the effect of events upon the personality as a whole. Because it receives the energies of all the preceding principles or Sephiroth, and holds them in readiness for the consummation of their final expression in Malkuth, it is called by Kabbalists the receptacle of the emanations, and is represented in astrology by the Moon.

10. MALKUTH (Kingdom) מלכות

Malkuth is called "Kingdom." It is here that the activity of the nine Sephiroth preceding it takes shape, where the manifest creation to which we have been referring continually is *seen* to be manifest. We

are told by tradition that Malkuth is a “fallen” Sephira, and that therefore its position as shown on diagrams of the Tree of Life is not as it should be. We can appreciate this to a degree when we consider that in the position of following Yesod it can only act in a very limited manner, acting in a similar way for manifestation as the Sephira Binah acts in principle. It represents in this place the principle which contains and confines the energies of the Sephira Yesod, giving them a means of activity. It is also related here to the World of Klipboth, or shells. The principle of Malkuth at this level represents the surface of the body referred to in Yesod; how a thing appears from its outward appearance. It is the surface of things, the shell which contains the elements which make up the body of things in Yesod, classified and arranged in Hod, differentiated in Netzach, given independent life in Tiphareth, based on controlled drives from Geburah, following the ground plan of ‘Hesed, which is contained within the framework of such a plan by the limiting action of Binah, which regulates the undifferentiated energies of ‘Hokma derived from the need of Spirit in Kether to become manifest. Malkuth is also called the Bride, and it is said of the Bride that she has to be redeemed, so as to take her rightful place upon the Throne of Binah. This redemption is the way of Kabbalah, and the work of the Kabbalist. It is interesting to note that the Hebrew title, *Malkuth*, has, in the original language, a feminine plural ending, which illustrates very well the proper sense of the term, for as physical inhabitants of this *Malkuth* we call “Planet Earth,” we are all shells or wombs in which may be born the expression of the One Life, the Eternal Unity, which seeks to make of each one of us a ‘receptacle of the emanations.’

PART TWO THE 21 STAGES DEPICTED BY THE TAROT

We have now described briefly the development of the Tree of Life from Kether (1) to Malkuth (10). With these basic principles to guide us, we can attempt to describe a journey in awareness portrayed as a return path from Malkuth to Kether. This begins in Malkuth and follows through 22 stages. As one is a stage of preparation, we speak in practice of 21. Here we describe the return journey as far as is practical for us, which is as far as the place of Daath. These may be described as seven steps, one for each Sephira from Yesod to Daath. (On the higher scale of the Ladder it is seen that as we reach a stage of genuine knowledge - as distinct from theory - each Daath or Knowledge stage is transformed into a Yesod or Foundation stage for the next level or world above).

In the 21 Stages, we can see from the diagram that before we move on from each stage to the next, we first look back and consolidate the work that we have done so far, completing the various triangles which connect the Sephiroth. Broadly speaking, stages which fall directly on particular Sephiroth represent definite levels of awareness, in the same way that the Sephiroth represent definite principles. The paths which connect them represent the activity of that awareness in its development.

(The whole arrangement of the 21 stages properly belongs in the world of Yetzirah on the scale of the Ladder as delineated in Part Three. The significance of this cannot be over-emphasised).

To reiterate what has been said elsewhere, the four worlds have a direct correspondence in the Christian tradition, which may be expressed thus: Heaven (Atziluth); Paradise (Briah); Purgatory (Yetzirah); and Hades (Assiah). If we choose to equate Hades with Hell, as is sometimes done, then this is an accurate description of the world in which we find ourselves. The classic descriptions of “Hell” leap out at us every day from our newspapers and television screens. We call it “The News.”

Who is to blame for the evil conditions and events which continually take place? The atrocities and horrors of this or that war in this or that part of the world? The rape and torture of women and children? The ever-increasing ability of human beings to devise “better” ways and means of inflicting the greatest possible agony upon each other? What kind of God, many people ask, created such a world for us to inhabit?

The answer is, or course, that no kind of God did any such thing. We have created these conditions ourselves, and it is *our* responsibility to change them. For each one of us, the only change we can make practically is a change within ourselves. It is easy to see that this or that world leader, dictator, politician, political movement, etc., is to blame for this or that condition or sequence of events. It may be that the blame we so readily apportion truly belongs where we allocate it, but *allocating blame does not change things*. As long as there are human beings ready to perpetuate such evil, and other human beings who are willing to allow it to take place then it will continue as it has done for centuries.

If we are honest with ourselves as individuals, we will acknowledge and recognise that we all, each one of us - and especially ME - has the capacity for evil, possibly as great as the most evil person in history. If we have any hope at all of changing the world order, then the first and most practical place to begin is on our own doorstep, that is with ourselves.

This, according to the Teaching, is the work which we each undertake in the world of Yetzirah, of Purgatory, of Purification. One way (and only one) of depicting this work is shown by means of the 21 stages.

This may seem very grand, but the reality of life is that we each pass through each of the 21 stages as a matter of life experience, for they also show the journey from birth to death. This is why the earlier stages may seem familiar, and more easily recognised.

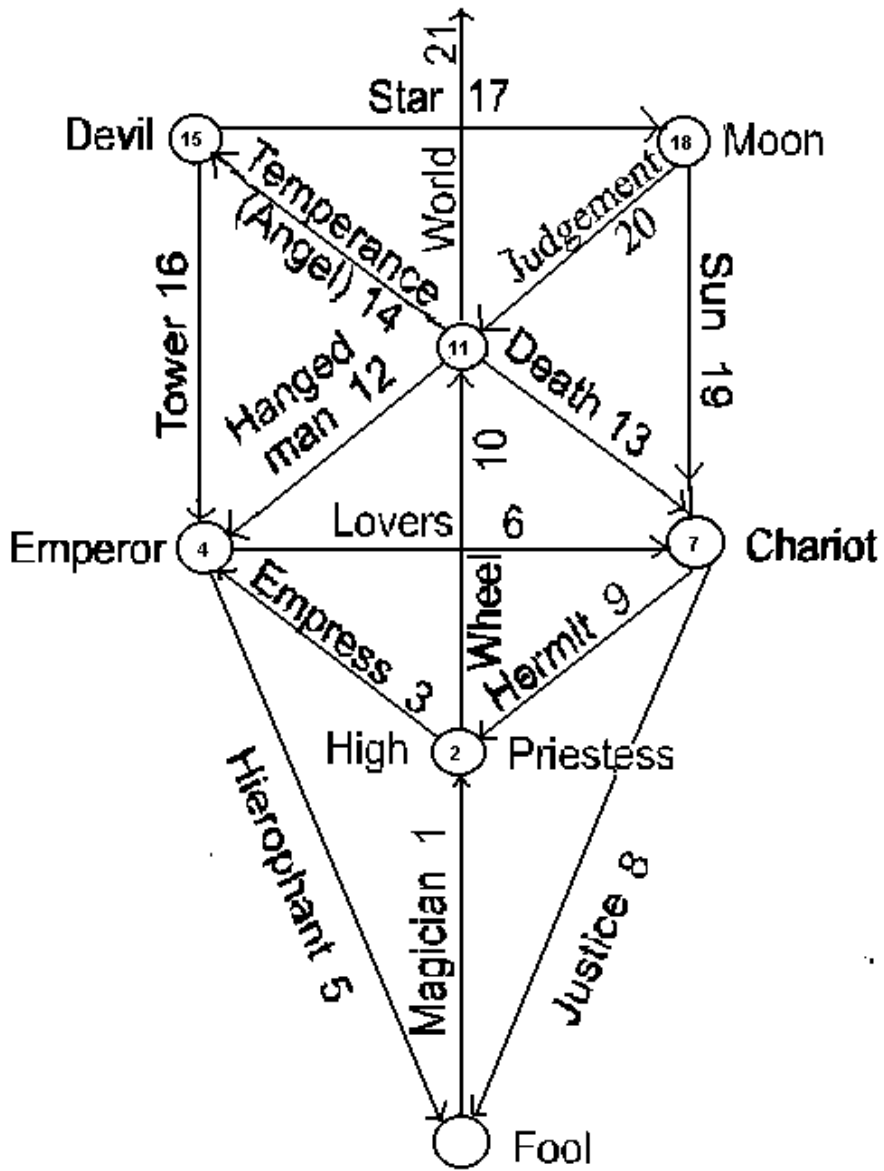
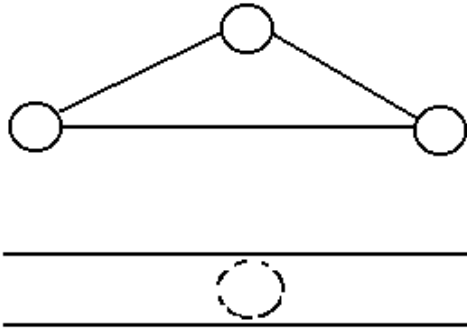

The arrangement outlined here differs from works based on the teachings of the Hermetic Order of the Golden Dawn and its derivatives. Any method, however, that is based on the Tree of Life will show a progression in reverse order of a “lightning flash,” as the present arrangement does with the Fool of the Tarot. The 21 stages do not attempt to show a progression into the highest spiritual levels. This is due to the relative position of the 21 stages on the larger scale of the Ladder, to be delineated in Part Three. They go, in fact, as far as the “Daath” of Yetzirah, which then becomes the “Yesod” or Foundation of the world of Briah, Creation, or Paradise.

The value of this is that it provides a practical guide to those who wish to chart their own progress without the necessity of consulting self-styled Masters or Adepts. Another advantage is that it is most practical to begin with an arrangement of what is available to us, namely, the Sephiroth of Yetzirah. What immediately follows is, therefore, a partial system of the greater teaching of the Ladder, though it can be used independently.

(While it is not vital to an understanding of this arrangement, it is of interest to consider the following remarks of Dion Fortune in her book *The Mystical Qabalah*, (4:12): “Concerning the Tarot cards, there are three modern authorities of note. . . . All three are different. Concerning the system Mr. Waite gives, he himself says ‘There is another system known to initiates.’ There is reason to suppose that this is the method used by Mathers.”)

It is this method that Dion Fortune adopted and published in her book. There is, however, even better reason to suppose that her attributions, as published, are not that of the ‘other’ system, referred to by Mr. Waite. One of the most widely used Tarot packs in modern use, and which is recommended to all students, is that designed by Waite himself, and faithfully portrayed by Pamela Coleman Smith. We may reasonably suppose from what he says that he was aware of this ‘other’ method, and that being so, he would be likely to incorporate it into his own pack. Without speculating further, it is interesting to observe that the internal evidence of Waite’s designs, i.e., the pictures actually on the cards, are more in accord with the arrangement of the 21 stages than with any other published system.

For example, cards 2, 5 and 8 (when the original numbering is restored) all show figures seated between the Pillars of the Temple. No other cards show such symbolism so clearly, and all three cards connect with Malkuth at the bottom of the Tree.

Cards 1, 10 and 21 all contain fourfold symbolism of a more specific nature. In card 1, the Magician stands in front of the symbols of the four Tarot suits on the table. In card 10 the four Holy Animals appear in the four corners of the card. This is repeated in card 21. These three cards all appear on the Middle Pillar of the Tree in ascending order (See “The Middle Pillar” below). Card 6 joins Hod and Netzach, and shows the Sun of Tiphareth shining behind the angel who veils it, while card 17 similarly joins Hesed and Geburah, and shows the star of Kether shining through a veil of seven lesser stars).

THE MIDDLE PILLAR

In this arrangement, the Middle Pillar reaches only as far as Daath, Knowledge, representative of the Supernal Triangle at the human, subjective level of awareness.* Let it be said here that all human awareness is ordinarily subjective, being even at its highest subject to infinitely more powerful laws of being shown “as in a mirror darkly.”

*(We shall see in Part Three that whenever a “Daath” position is reached, it becomes, to developing awareness, the “Yesod” or Foundation of the level above, and there is another Tree to climb!)

With this in mind, we may nevertheless consider the relative significance of the development of awareness as portrayed by the 21 stages, and in particular the symbolism of the Middle Pillar upon which three major changes in awareness can occur. The stages concerned with this process are Stage 1, lifting awareness from sleep in Malkuth towards Yesod, shown by the Magician; Stage 10, raising Personality awareness in Yesod to Self awareness in Tiphareth, symbolised by the Wheel, and Stage 21, elevating Self awareness to its maximum development towards Daath, Self Knowledge, or Spiritual Awareness, symbolised by the card “The World.” These three cards are the only ones (in the Waite pack) which clearly show the symbolism of the four worlds. As we proceed, the relevant equivalent location of the important stages as described on the greater scale of the Ladder in Part Three of this work will be given, and in some measure connected to their relation to the 21 stages.

In Stage 1 the Magician has available the four symbols of the Tarot suits, representing Fire, Water, Air and Earth. These may be taken to represent the tools we learn to use on our journey.

In stage 10, the Tarot card The Wheel shows the four Holy Animals in the corners of the card, each with an opened book. This symbolises the work we have to do in order to apply our learning and further our progress. In stage 21, the same Holy Animals again occupy the four corners of the card, but

this time as simple representations without wings, books or other attributes, symbolising the simplicity of true knowledge.

The symbolism of these three cards, together with card 6, The Lovers; card 17, The Star; card 2, The High Priestess; card 5, The Hierophant, and card 8, Justice, suggests that A. E. Waite may have had a very similar arrangement to that which is used here before him when he designed his own cards.

THE ATTRIBUTIONS

A few words are necessary here, for we are dealing with an aspect of the teaching on a different scale from that of the 32 Paths outlined in Part Three. The main point in need of emphasis is that while that which is above is like that which is below, it is by no means the same thing, and that which adequately illustrates one level cannot necessarily be easily or directly transferred to another. The view from the upper deck of the bus is not the same as that from the lower, even though both share the basic principles of bus arrangement. Accordingly, the attributions of the Tarot trumps to the 21 Stages of the Way are different from those of the downward flow of the 32 Paths. There is no contradiction in this; the same tools are being used in a different manner, that is all. For example, we may use a spoon for stirring, for measuring, or for cracking the top of a boiled egg.

When, in due time, we have used the tools and completed the building of the “Temple not made with hands,” we put the tools aside. *This work is not a game to be played*, and although “magical” symbolism is employed by the Tarot, any ideas we might get that we are in any way some sort of “magicians” with “special powers” belong to the comic books and science fiction or fantasy movies, not real life. Real life is much more clever than that.

The foundation of the Tree of Life is the Sephira Yesod. It is represented in the 21 Stages by The High Priestess, card 2. Below her are two figures; the Fool and The Magician. The Fool, in Malkuth, has yet to awaken and knock at the gate. “The Gate” is one of the titles of Malkuth. When we awaken, due to events and circumstances outside of ourselves, we come under the influence and operation of Step 1, called elsewhere “right impulse” or “good impulse” and develop a desire to seek Knowledge. In doing so, we become a “Magician,” armed with the tools symbolised by the objects on the table before us. The process of awakening has begun, and can continue until we become Self-aware in Step 4. We begin to apply the virtue of Malkuth, discrimination.

Here we stand at the entrance of the outer court of the Temple, as prepared as it is possible to be, seeking admission. Before us are three figures, all representatives of the Temple, only one of whom can grant admission. On one side is the figure of the Hierophant, seated between the Pillars of the Temple. A priest, however, cannot grant admission, for priestly work is to expound the teaching in a manner acceptable and intelligible to those outside the Temple gate, whether they seek admission or not. On the other side is the figure of Justice, who also cannot grant admission, for this work is to bring the unseen influences of the teaching to those outside, and to assess the worthiness of applicants for entry. By these two, after a manner, the candidate has already been prepared, and stands at the feet of the High Priestess in Yesod, who holds the scroll of the Law, and who alone can grant admission to the outer court of the Holy places.

THE 21 STAGES OF THE WAY

“The Fool”

This is not properly the first stage in the journey towards Self-awareness. Rather is it a necessary pre-stage whereby a certain amount of preparation has already been done. As it is an absolute necessity that this preparation is made, a great deal of importance is attached to it. This takes place very much in the everyday material world, and is concerned with the body of things as it appears to unawakened awareness. It is only the body, not the soul, nor the spirit, except by reflection, and body may also be symbolised by our own planet, the Earth itself. The body is a shell, a container - in this case for the soul and Spirit which motivates it. And the world of shells or husks is called, in Kabbalah, Klippoth. It has nothing to do with any kinds of demon, except perhaps the ‘demons’ we are ourselves.

Here we may be compared with the figure on the card, from the point of view of the development of awareness. We are governed by what are basically bodily considerations, though we may not recognise them as such, attributing our desires to outside influences and other people.



Even at this early stage, a higher consciousness is at work in us, seeking to develop, to bring us closer to Self-realisation. This causes us in different ways, depending upon what sort of persons we are, to attempt to change direction and to make the fullest use of choice. At this stage, however, we do not know enough to do this properly. In fact we do not usually know that we do not know, often supposing that we know a great deal. We need to learn that what often appears to be decision based upon experience may in fact be no more than conditioned reflex, built-in reactions to events and circumstances, having little to do with choice on our part at all. The more our awareness struggles to develop however, the greater the likelihood of our following the path of the figure on the card. The dog at our heels represents the law which governs the direction of things, and the body of things. It is attempting to tell us to wake up and look where we are going. As generally we do not realise that we are (in relative terms) asleep, we take the unavoidable step over the cliff, and find that our previous values no longer apply; this is the Awakening - with a bump, always, and sometimes painful.

Putting this another way, before the first step proper may be taken, we must see that we have been living our lives as if asleep, treating dreams as reality. The awareness of life that is possible, compared to what sometimes passes for it, is like the difference between sleep and waking. To begin to know ourselves, we need to see how much we have been spending our lives in a sequence of action and reaction. To see this, all that is necessary is a little honest observation of our own behaviour. The first thing is to 'Wake up' if only for a moment now and then. The key to this is observation, coupled with discrimination - the virtue of the Malkuth. Observation of action-reaction in the events of our daily lives; observation of the appearance of things. To do this, it will help if we remind ourselves as frequently as is practical, to stop. That is, whenever we remember, deliberately to interrupt the flow of action-reaction in which we are engaged, to stop and observe what is. Common sense should tell us when *not* to practice this exercise. We may be surprised at what we discover.

On the scale of the Ladder, this position is directly related to Path 28. The text for this path states:

"The Active Intelligence. Thence is created the spirit of every creature of the supreme orb, and the activity, the motion to which they are subject." By "creature" is here understood the animal body, which has an intelligence of its own, not the soul or spirit who inhabits it (you or I, for example). A major realisation for us at this stage is to recognise that we are not our bodies, but something else. The quest for that something else now becomes our immediate concern. Intellectually, this may appear obvious, *but this work is not an intellectual activity*; not an interesting mental exercise. It is learning to recognize our true psychological and spiritual identities. It is about living what we do and learn.

Stage One, "The Magician"

When first we open our eyes after the Awakening, it is as though we have passed through a gate into a new and unexplored region. This stage takes us from Malkuth, the world of appearances, to Yesod, the Foundation. These connecting stages represent the activity of consciousness, and we can expect to be particularly active during this first stage. So, of course, it always is when we discover something new which invites us to explore. The hidden potential stored in the 'foundation' of our natures is ready to be stimulated into action, and will have definite effects in the real world. One of the titles given to Malkuth is "The Gate" a title also given in esoteric astrology to the sign Cancer, ruled by the Moon - also attributed to Yesod. One quality of this sign of the zodiac is that of holding tightly to that which we possess; a self-contained principle which at times can degenerate into avarice, a vice associated with Malkuth. Another aspect of this sign is what is often described as moodiness - a description of some Cancerians which may not be gratefully received. More accurately this impression is formed due to a tendency to engage in a considerable degree of reflection, often quite deeply.

The Moon, we know, reflects the light of the Sun, and Cancer is a sign which may produce people who often unerringly capture or reflect the activities and attitudes of others. This can sometimes incline to participation in some form of entertainment or theatrical activity. The important thing is that the talent for reflection can be a form of accurate imitation, although it may over- or under-stress certain aspects. So it is with us. In order to understand the nature of people, particularly of ourselves, we need to gather with crab-like tenacity the qualities which may be used to reflect and direct the qualities of the inner and deeper levels of our being, beyond the superficial appearance; to learn to know and understand both ourselves and others, and in so doing, *to make improvements*. The source of light at this stage is symbolised by the reflective Moon of Yesod, at the feet of the High Priestess, the receptacle of the emanations; the vast hidden potential of the Tree of Life itself, of which it is said that it has its roots in heaven and its branches in Earth.



At this stage we are particularly under, and sensitive to, the influences of psychic “moon” forces, and the tenacity and self-containment of the crab are necessary to keep our balance. This is also the very first step in the purification of awareness, and for this reason we must keep ourselves very much awake and alive to the power of the hidden potential whose energies lie before us. In the Waite pack the ‘Magician’ is shown with five objects, four on the table, and one in the raised right hand. This latter represents freedom of choice and action, free will, while the other hand, pointing towards the earth, represents the direction in which the power is to be employed: in the real world of living things, symbolised by the growth of vegetation in front of the table.

On the table itself are four symbols: the wand, the cup, the sword and the coin. These four symbols relate directly to the four worlds of Kabbalah, and to human nature. The wand represents the world of Atziluth; in us it represents our spiritual origin. The cup represents the world of Briah, or world of creation; in us it represents our most fundamental essence, an essence of Spirit, which in its original purity is called *Yechidah*, recognisable by us only through Knowledge. *Yechidah* carries the connotation, in Hebrew, of “only child” or “only-begotten” and thus points towards a perception of the otherwise absurd Christian doctrine of The Christ as “only-begotten” of God. The Atziluthic principle in us is called in Kabbalah, ‘*Hia*, usually translated “life” but as it is used here is particularly related to the One Life of Kether, origin of all life and of the Tree of Life. The Hebrew word is also the root of the word for “Eve,” described in Genesis as “the mother of all life (or living).” The Briatic principle in us is called *Neschamah*, which may be translated loosely as aspiration and ideals. So we may say that in order to perfect ourselves we must aim for union with the One Life of Kether, via *Yechidah*, or the spirit within ourselves, and which we truly are.

The sword represents the world of Yetzirah, and the power of reason, properly understood as the intelligence which makes us human in a way different from other creatures. It is this native human intelligence which we now must learn to use as our “sword” of truth, to separate and discriminate between that which is real and that which is not. Discrimination is the virtue of Malkuth. It is the development of this quality which has brought about the Awakening. As we now learn to discriminate between previously hidden qualities within, so we develop in proportion the virtue of Yesod, which is Independence.

Although the stages of the Way are each symbolised by the figures on the different Tarot cards, we remain fundamentally a “Fool” in different situations. The differing images on the cards represent the forces and principles which impress themselves upon us, and which we seek both to reflect into the world, and to reflect upon in our journey towards knowledge and understanding.

The coin represents the world of Assiah, of the visibly material, and is represented by what is known as *Nephesh*, which has been interpreted as the animal passions. The use of the word “passions” is a little unfortunate, for modern usage has distorted its original meaning. It is better to think of this principle as our animal nature, closely related to the body itself, which is the animal form within which we are temporarily confined. The important thing to understand is that in all the stages of the Way the work we do is reflected through this animal body and animal nature. It is with this nature and this body that we will give expression to the principles and forces that we come to know, and which are impressed upon us. The activity of these principles and forces will reflect through us according to our understanding, combined with the direction of the will. The energies invoked by the wand in the right hand will have to pass through the ‘magician’ (you or me) before they may be directed into the world by the downward-pointing left. It is therefore wise for us to note that this wand is double ended, and that the sword of reason is double sided - discrimination, in other words, is absolutely essential in all 21 Stages.

Stage Two, The “High Priestess”

In the second stage we meet for the first time the principle of Yesod, the foundation. This is a first exploratory meeting, for the complete foundation is that of a rounded and integrated personality - a work which never ceases in life, however far we progress. The stages of personality are the first ten stages along the Way. When we have returned to Yesod a second time via stage nine, and with our feet firmly on this foundation, we may, if we are ready, take the path of the wheel in stage ten in an attempt to lift our entire level of being from personality, based on the Yesod foundation, to Self, which centres on Tiphareth. This step has been described by one school as a change in our ‘centre of gravity.’

In stage two, however, we touch the principle upon which personality is based as an apparently unknown and very powerful force in our lives - which it is. In speaking of the sign Cancer in stage one, we said that it was ruled by the moon. From the point of view expressed here, we are saying that in Yesod lies the controlling power which is itself the root cause of tenacity and the reflective



qualities we need. In astrology, the element of water is assigned to Cancer, and it may be said that the foundation of human personality is of a watery, fluid nature; reflective, as water at night may show the reflection of the moon in the sky, and as the moon itself reflects the light of the sun.

This illustrates very clearly an aspect of the Teaching, that the main function of personality is its capacity accurately to reflect the light of Self from Tiphareth, to which Sephira Kabbalah attributes the sun.

At this point it is appropriate to say something of what are called the chakras in the human body, and of the subtle body of refined matter commonly referred to in occult literature as the etheric body, or etheric double. It is called a double because, in appearance when seen apart from its denser, more material counterpart - the "shell" we have already spoken of - it is a whitish replica of the physical body with which we are familiar. This etheric body is referred to Yesod, and it is this body which separates from the shell of the physical in certain kinds of out of the body experiences, and at physical death. These experiences are commonly called astral projection, but "astral" projection and etheric projection are not the same thing. In etheric projection, consciousness is transferred to this "Foundation" body upon which the physical is moulded, and is able to move around in the usual surroundings of the everyday world, which appears exactly as we see it in the normal waking state, except that we may notice a kind of white "mist" pervading everything, called by some the "astral light." This is a term which has had its meaning blurred from too much usage by too many people with not enough understanding or experience.

In "astral" projection, the contents, or rather particular aspects of some contents of the psyche, are capable of being projected onto their own plane, which may be an inner, subjective one or an outer objective level one step removed from the etheric conditions mentioned above. It is on this Yetziratic or astral level that the so-called angels and demons, etc. of so-called 'magical' operations are encountered, and it need hardly be said that such experiences are of the inner subjective variety, *and in consequence not reliable as evidence of anything except perhaps the state of mind of the person experiencing the phenomena*. Such experience properly belongs to psychology - but psychology is itself an important study within the Teaching. On one scale Yesod is seen as the lowest Sephira in the world of Yetzirah, and it is important to realise that in Yetzirah the products of fantasy have as much apparent reality as the record of material events held in the memory. Behind this simple fact lie the roots of some psychological or psychic disorders.

The chakras are centres of force, or energy, within the etheric body, and have a similar importance to this body to that which the organs of the physical body have in the material world. In both cases, the organs of the body are vital to existence. The first or lowest of the chakras is related to Malkuth, and the posterior pelvic plexus or nerve complex in the physical body [the *Muladhara* chakra]. In practice, the relationship between the etheric and physical body is maintained by these complex nerve centres throughout the physical body. Under normal circumstances the etheric centre, or chakra, appears to be interwoven with the physical nerve complex or its equivalent by very fine connections or threads of etheric substance. In etheric projection, these connections are loosened so that the etheric double may act independently of the physical, and the energy interplay which is necessary between them to maintain physical life is said to be maintained by what has been called in occult and spiritualist literature as "the silver cord." This is usually seen (when it is seen) as connecting the two bodies, either via the solar plexus centre, or the centre between the eyebrows. Some researchers however do not report such a cord, and appear to be able to function without one.

There is an aspect of the Malkuth centre which is related to the anterior pelvic plexus in the body, that is to say in the front, and this is referred to Yesod rather than Malkuth [the *Svaddisthana* chakra]. It is useful and practical to consider these two lower Sephiroth as two parts of a single whole.

From the point of view of the development of awareness these lower centres are particularly related to the first two stages of the Way. The main function of these two *plexi* and their etheric counterparts is the maintenance of the "automatic" bodily functions such as walking sleeping and breathing, as well as the excretion of waste matter. At the same time, the anterior [front] pelvic plexus is very much concerned with the mechanics of sexual behaviour. It cannot be stressed too strongly that it is the mechanics, not the delights that are referred to. We may find in stage one, and more particularly stage two, that sexual awareness is heightened. This level is closely related to *Nephesh*, and our animal nature, and at this level sexual awareness is of this kind. The more easily recognisable aspects of human sexuality which we experience as excitement, but of a different kind, such as attachment to particular aspects of sex, and which stir our feelings and thoughts, do not belong here. Even so, the attraction of the *Nephesh* nature is very powerful, and probably accounts for more of the underlying attitudes and conditioned reflex mechanisms in the human personality than is generally realised.

As ever, the essential approach in such matters is that of discrimination and observation. The next centre with which we are concerned is the solar plexus centre, related to the *Manipura* chakra and stage

ten of the Way; it is at this level that we, as ordinary human beings, live our lives. This life is based on personality and the four lower Sephiroth. From this point we may, when we are ready, take the step to Self-awareness and transfer our centre of being to the heart centre, related to Tiphareth on the Tree. The Indian method of mantric meditation imported into the West by the Maharishi Mahesh Yogi is based on a Hindu mantra related to the solar plexus, and we can see how such a method is intended to work upon a particular centre in order to strengthen it. This is one way of building a firm Yesod, a firm foundation, for when we come to stage ten, we return to Yesod a second time, as can be seen from the diagram illustrating the 21 stages. From the point of view of the Teaching, such a method used on its own has many shortcomings. It is important to us not only to be able to go somewhere, to be somebody, and to grow in awareness, but also to know where we are, where we have been and to see where we are going, or as much of what lies ahead as may be possible. This is why we have a map, called the Tree of Life, and the information necessary to interpret it.

We find it useful to know, for instance, that the Hindus have other mantras for other centres, and are thus able to put such methods into perspective in relation to the whole being, an advantage that someone who practices mantric meditation with no other experience than the mystique of an initiation ceremony in Sanskrit does not possess. [Details of these can be found in the *Pelican Book, Yoga, by Ernest Wood, p. 152*]. This is not to say that such a method of meditation should not be practised - quite the reverse; but it is to say that such practices are more effective when allied to a system of thought, and to a teaching. Sanskrit is the language of the mysteries for the people of the East. For the West, it is the Hebrew of the Old Testament and the Kabbalah, from which tradition Jesus appeared. Having said this, it is also said that all versions of the teaching originates in one source, and that all traditions are branches of one tree. Only good can come out of a marriage of East and West. A glance at both Hebrew and Sanskrit writing still shows traces of what may have been a once common, but long forgotten, language.

After the heart centre [*Anahata* chakra] of Tiphareth comes the throat centre [*Vishuddhi* chakra] referred for convenience to Daath and stage 21 of the Way. The centre between the eyebrows [*Ajna* Chakra] is related to that aspect of Daath which lies on the other side of the Abyss, and the *Sahasrara* chakra, above the head, presides over all like a crown, and is referred to Kether. In the development towards material expression down the lightning flash from Kether, Yesod, foundation, refers on the human scale to the etheric foundation upon which the human body is built. In other words, the etheric structure comes first, and the physical is moulded upon it. When the physical body dies, the etheric does not, remaining for a short time the outer container for the individual within. When we first approach Yesod in stage two, we begin to touch upon this level as separate, and to feel something of its power and mystery, a feeling well conveyed by the image of the High Priestess. We are, at this point, on the threshold of the Temple, and if our work is properly done, we will be able to pass between the two pillars and approach the holy places within.

On the scale of the Ladder, this position is directly related to Path 25, the text of which states: "The Intelligence of Temptation or Trial. It is the first temptation whereby God tests the devout."

Stage Three, The Empress

The tarot attribution of the Empress depicts the powerful forces of life in motion. The natural impulse of this path is from Hod to Yesod, whereas we are seeking to develop against the flow, in the opposite direction to the lightning flash, and progress from Yesod to Hod. It follows that the discrimination of Malkuth and the independence of Yesod are very necessary to attempt this stage. As we saw when describing the Sephiroth, the vital energies of life flow down into the receptacle of the emanations, the form-giving Yesod, and on this path the keyword might well be "vitality". It brings to the body the vital energies of Hod.

It is clear that we need clear heads in order to keep above the rushing waters of vitality shown on the tarot card. We learned under Hod when discussing the Sephiroth that this Sefhira is concerned with classification, arrangement and communication. This is the work of step three, (*see the Seven Steps at the end of Part Two*). To this may be added analysis, showing yet again the importance of discrimination. We need to consider all that we have discovered about ourselves and our world, and all that we are learning still, and relate each to the other and ourselves, using the framework of the Tree of Life as our guide, until we have established a certain stability of thought and approach, which is to become symbolised by the Emperor in stage four.

We may think here of the vital energies referred to in relation to the etheric body discussed in stage two. This body has been called the vital body, and the "powerhouse" behind our physical manifestation. Whereas we referred to individual chakras previously, we may now begin to realise that



there is a continuous interplay of energies between them, and also a giving and resolving of vital energy to and from our environment and other people, so that the “astral light” spoken of in stage two is, in fact, the medium via which these energies are transmitted from place to place. Some people have an instinctive understanding of such forces, and are able in some measure to take advantage of others, and rob them of vitality. This may well be the basis of “vampire” legends, but in general is much simpler to deal with than by running around with wooden stakes and mallets.

The simplest way to deal with such a problem is, not surprisingly, to remove ourselves from the presence of whoever it is that is affecting us in this way. Even so, the following comments should be noted. Such activity takes place through the solar plexus centre, provided that the body is “open” to it. As the body is a complete circuit in itself, we may be able to protect ourselves against unwanted loss of energy (which some people can feel draining away via this centre) by closing the circuit to outside influence, making it self-contained. This is done by ensuring that the feet and hands are together, touching or clasped (or arms folded). If the feeling of loss persists, or is particularly severe, it will help to contract the muscles around the solar plexus, the muscles of the abdomen, and temporarily to hold the breath. The breath should be held where it is, that is to say, do not breathe in or out, but simply halt the breathing process wherever it is at the time. It is difficult for energy to drain away under these circumstances, though it must be said that this method is not infallible, and may not work for everyone. Such vitality loss is not necessarily due to the behaviour of others, and can be due to a simple dissipation of energy on the part of the sufferer - probably the most common cause, though we all no doubt know of people who “drain” us, and whom we instinctively avoid.

It will be appreciated that knowledge of these things is gained by observation and experience - as is knowledge of anything. (There is a difference between knowledge and information). To be of use, information must be arranged, related to other information, and communicated. In stage three we learn to do this for ourselves.

Stage Four, The Emperor

The symbolism of the Emperor is an apt illustration of developing awareness and individualisation. Hod is an active Sefhira, and we may recall to advantage the aspects of Hod previously referred to of analysis and classification. To quote from the previous section on Hod, “the differentiated parts of the manifestation of spirit originated in Kether begin to become autonomous.” So at this stage it may be seen that we have come to the place where our own integrity, honesty (the virtue of Hod) and individuality begin to find real expression and importance. Because of this we find in practical work that people progress fairly quickly through the first three stages into stages four and five. The real difficulties begin in stage six, for by this time we shall be moving away from our own egocentricity towards more universal principles and qualities of Self.



The figure on the card is very impressive, in royal robes, carrying orb and sceptre and seated on a throne; but the symbolism may not appear so glorious as first impressions suggest when we observe the territory which is ruled over. It is a realm of rocks and mountain peaks. This is the place of the rationalising intellect. There is a fascination about intellectual capabilities which can take hold of us, and we may find that a love of classification, categorising and rationalisation, while being necessary to our appreciation and learning, can hold us back and delay our further development if we engage in it for its own sake.

We need to avoid the temptation of substituting intellect for understanding, and information for knowledge, else our environment may become as sterile as the rocks which surround the emperor. If we succumb to this temptation we may sink into smug complacency, unlikely to develop further.

Usually, however, having reached the heights of intellect, the very satisfaction with our own progress is likely to provide a spur, for who can resist an occasional glance, or even several glances, at the spot from which they began? Indeed, at this stage we are in a position to use what we have learned, and to place it at the disposal of others following behind, which we can begin to do in stage five. Before we move on though, we should begin to appreciate the deeper function of intellect, namely the ability simply to sit, like the emperor, and watch in silent contemplation.

On the scale of the Ladder it is represented by Path 24, “The Imaginative Intelligence.” True contemplation is indeed an imaginative process - and constructive - but there is no cause for complacency.

Stage Five, The Hierophant

This card is called in some packs “The Pope,” and the figure on the card is in a position of great respect. So we feel ourselves to be at this stage. We have progressed considerably since we began, and are

aware of it. In learning to use our intellect to the best advantage we find ourselves able to discourse, and to be listened to, by those who have not travelled so far. Perhaps, however, we seem a little pontifical and condescending to them. We may feel this to be justifiable, for even as far as we have travelled (it is not very far) the way has not been easy - but we have no cause to be smug.

Even so, we are well equipped to be of *some* help at this stage to those beginning their journey by being able to see clearly some of the conditions which apply *en route*. Looked at on the diagram of the 21 stages, we see that this stage links the Sephiroth Hod and Malkuth, and we are now in a position for the first time since we began to establish where we are by reference to two other points, much in the same way as a navigator of a ship at sea might take bearings to get a "fix" on the ship's position. Many people linger in this stage for some time, valuing the stability which can be achieved here. Some become identified with their new condition, and slide quietly along the direction of the arrow towards Malkuth, applying their new knowledge solely to the material side of life, finding that greater appreciation of the laws of action and reaction is of value in their everyday lives. They do not seek to travel further, nor should they feel that they must.



Higher Self-awareness is not immediate for everyone, and those for whom it is may not need to pursue it immediately when stage five has been reached, though they may well take up the journey again after a longer or shorter interval. If we feel inclined to go no further, or simply to take a break, then stage five is a good place for us to pause, whatever we may do later.

Nonetheless, all are advised to persevere as far as stage five of the Way, for this stage takes us back down to earth, to Malkuth, where all our work takes place, whatever we do.

For those who go on, however, Step two of the Seven Steps remains to be consolidated, and there is one more stage before this is done. For most of us it is the stage where the road begins to climb uphill, and we need to go twice as fast just to stay where we are. This is stage six.



Stage Six, The Lovers

This card shows very clearly our state at this time. It is here that we begin to feel the power inherent in our own feelings; the strange quality that lies in intuition and the glamour attached to sex. It is a very different kettle of fish from the orderly regulation of the neat "Thou shalt" and "Thou shalt not" of the intellect. The guidelines of stages four and five seem of little value here, yet we shall find that we need to refer to them again and again.

We may discover that we are reluctant to undertake this part of the journey. Finding ourselves half way across this path can become alarming - we can begin to swing between intellect and feelings like the unregulated pendulum of a crazy clock. Here we first begin to make the decision whether to go on or turn back, and it may seem that it is as difficult to do the one as it is to do the other. Make a choice we will, however, for the immediate goal of our journey now begins to be

visible in the distance as we become dimly aware of the possibilities before us. This is illustrated by the symbolism on the card. This stage is the Path which joins the Sephiroth Hod and Netzach, and if we look at this path we see that the Self of Tiphareth, the very centre of the Tree, stands immediately above us, like the light behind the figure in the illustration. If we become aware of this to any appreciable degree, we shall go on, for we become aware that the voice which calls us onward is our own, calling from deeper levels of being.

Stage Seven, The Chariot

The figure on the card is handsomely attired, shaded by a glowing canopy, and the horses are two sphinxes, one black and one white, perhaps similar to the Chinese Yin and Yang in intent. The chariot has no reins, and the sphinxes are very firmly sat down, unlikely to go anywhere. This does not appear to disturb the charioteer. It is easy to see that the fool who began the journey, now a charioteer, having escaped the austerity of the intellect, needs to relax for a time in the gentle glow of feelings, discovering new delights in appreciating the environment in terms of intuition in contrast to the mental gymnastics which are encouraged by intellectual pursuits.



We may tend, at this stage, to use our “canopy” a little too much to shield us from some of the unpleasant aspects of reality, looking at the world through rose-coloured spectacles.

To begin with, in stage seven, this is quite natural, and also quite necessary, for it takes a little time to assimilate new experiences of feeling-based events in life. Not that we did not experience such things before, but now they become more conscious.

Throughout the first three Steps, in fact, there is nothing new in our lives other than that we begin to experience more of the events of life consciously, with the difference in attitude that accompanies such activity. Indeed, it is our very awareness that is being developed, to the point where the seat of consciousness is transferred, in Step four, from the personality, or little ego, to Self.

After a greater or lesser degree of relaxation in stage seven, we begin to realise that we are in the position of being “all dressed up with nowhere to go.” We soon find that we can apply this awareness for the benefit of those following behind us on the Way much as we did in stage five. This we begin to do in stage eight.

On the scale of the Ladder, stage seven is related to Path 23, “The Stable Intelligence.”

Stage Eight, Justice

When, in stage five, we were able to help those behind us, we were able to do so only in an intellectual manner, classifying and analysing information, pigeon-holing the particulars of our understanding. To do the same thing from a feeling-based approach is not so straightforward, except that by lending a sympathetic and understanding ear, we can sometimes be of more service than in any other way, simply by virtue of experience and the watchful use of intuition.

There is also a tendency at this stage to judge or assess other people, feeling how they fit into the pattern of life, comparing their condition with our own and profiting by the comparison. We may also, as may be obvious, fall easily into negative criticism, particularly if our feeling nature receives a few knocks. We can avoid this danger, if we are wise, by putting our experience and understanding to good use, an activity which brings its own reward.

Gradually, as we come to terms with our feelings and come to understand the powerful effect that feeling as such has in the world around us, even though it is, for the most part, unconscious, we gather to ourselves the knowledge gained by means of our intellectual capacities, together with the limited experience of our instinctive roots, and the understanding of the conscious awareness of feelings (and feeling itself).

We can now begin to work towards Step Four, in which we hope to become truly Self-aware; but first we must consolidate our position and establish a firm foundation from which to take such a major step. This we shall begin to do in stage nine, attempting to bring together Knowledge (Step Two) Understanding, (Step Three) and Being (Step One). For any major change in awareness to occur, these three factors always combine to provide the necessary impetus, as we can discover for ourselves.



Stage Nine, The Hermit

In this stage, we take the final steps to establish our foundation - Yesod, towards which Sephira we now return - and the first part of the preparation necessary to reach Self-awareness.

The figure on the card shows a wise man, with the staff of knowledge and the light of understanding going forward alone to establish true being. Now we are necessarily alone for a time, and we withdraw from instruction, from seeking experience in our environment, stepping out unaccompanied, using the light we have gathered in these preparatory stages to guide us. We are getting closer to Self, and we look inward more deeply than before in order to integrate the personality attributes of intellect, feeling and instinct, making of ourselves a unity at the lower level of being, so that we may rise to the higher level of Self. We have experienced each of the three lower attributes separately and applied this experience to ourselves and to our environment. Our task in stage nine is to weld this experience together in a “whole” personality and thereby complete a solid foundation on which to build further.



Stage Ten, The Wheel

Prior to discovering Self, or to be more accurate, unveiling Self, this stage is the most important of the first ten. Here is the opportunity to transcend personality and to begin to realise Self. We find that

this is not so easy, for the gate into Self is narrow, and we have to pass through the veil that shrouds the light of Self, shown symbolically behind the High Priestess in stage two, and by the wings of the angel in stage six. To make the transition from personality awareness to Self awareness requires sacrifice. The word sacrifice is used in the spiritual sense of transmutation or change, and not in the sense of “giving something up.” We may need to change our attitudes to some most dearly held ideas, ideals and illusions. The personality experiences the cleansing light of Self examination, so that it may be a worthy tool for the use of Self.

Habits die hard, and this truth is demonstrated here. We may find that we have to follow the path of the wheel around the instincts, intellect and feeling many times again, discovering and integrating parts of personality that we previously overlooked before we are in a condition to enter into the heart, where Self resides. In a sense we are back at Path 25 on the scale of the Ladder, “The Intelligence of Temptation or Trial, by which God tests the devout.”

Attitude attracts environment. Think about this.

Many remain at this stage for a long time - without much ambition to go further, being satisfied with a firm foundation and a rounded and integrated personality which brings them true independence - the virtue of Yesod.

There is no “fault” in this. They have achieved more than some who are still buffeted by the winds of circumstance.

To enter the next stage, and to take the next Step of the Way requires simple devotion. The ties which bind awareness to personality must be loosened and let go, personality left behind (but by no means forgotten or lost) so that we may discover Self as unadorned as a new born child. It is a Step, and a devotion, that demands the firmest of foundations and a great deal of courage.

If we choose to go on, we shall need to adjust our attitudes, desires and ambitions in terms of Self awareness, terms which we do not, cannot fully understand, for we see “As in a mirror, darkly,” and we must take Self on trust. Given the courage, we can do this, for the Self that we seek is no stranger; it is the Self which we are, and the personality which we are not. Personality is simply the means through which Self finds expression, which it has in fact been promoting all along, except that we have not been aware *as Self*, being identified with various aspects of personality.



Stage Eleven, Strength

The Tarot card “Strength” is the most subtly representative of balance in the whole of the Tarot. It shows a simply dressed woman bending over a lion and holding its jaws. There is no coercion or exertion; no domination. The lion appears quite calm; the woman is in command. This card symbolises Self-control - i.e., control by the Soul, or Self; control, in fact, of the lower levels governed by Yesod and personality. Nowhere is seen the fierce determination of the fanatic. The woman [soul] is serene; the lion [personality] is obedient.

This is precisely the relationship we shall find with personality when we discover Self. We become aware of freedom and clarity. Someone once described this condition as being like a day in the country after it had been raining. Everything is sharper and clearer. Here we can no longer fool ourselves about what we want or what we are. We may ignore what we see, but we can never ignore the fact that we have seen it.

Some approaches end with the discovery of Self, for when Self is discovered, we have found an expression of Heaven within. Some, however, will want to explore this new-found condition.

Those who go on seek to take the journey three major Steps further. In order to truly know Self, we first discover Self, and then learn to be Self. We investigate and integrate the parts of Self much as we did with personality. There are problems of Self to be resolved, and we shall need to resolve them. After this comes the realisation of Self, in the way that one “realises” assets by putting them to practical use. Before we continue - if we so choose - we pause here and consolidate what we have learned.

The next journey is a quest for Spirit, both human and divine. If we are determined to persevere, we may learn to converse with angels, to come to know and recognise the spiritual presence in the Creation.

On the scale of the Ladder, this stage is represented by Path 22, the text of which states:

“The Faithful Intelligence. Spiritual virtues are deposited and augment therein, until they pass to those who dwell under the shadow thereof.”



Stage Twelve, The Hanged Man

When we have taken so great a step forward as we do in becoming Self-aware, it is not only natural but very necessary that we consolidate our position by reference to what has gone before, in order to have a clear idea of our whereabouts. In this stage we establish this by reference to the analytical and critical faculties of the intellect, below us in Hod.

The figure on the Tarot card is suspended by one leg over a pit, with a kind of glow, or halo, around the head. We can see that the view of the intellect regarding Self and Self-discovery that we had at stage four was, after a manner, quite upside down. We were able to see that Self-discovery would require sacrifice of some kind, but that we viewed sacrifice as being a loss. We can now appreciate that we have in fact gained considerably; that the power of intellect can now be a pure force, like the halo on the hanging figure; a force and a capacity that we are able, possibly for the first time, to use consciously, without identifying Self with our thoughts and ideas.



For we are not our thoughts; we *have* thoughts. We can also see how incomplete we were during the first ten stages. We are able to use intellect, to observe our thoughts as separate, individual events that are part of our experience of life.

In life there are two kinds of events; outer events, which take place in the circumstances of our environment, affecting us to a greater or lesser degree, according to their importance to us, and inner events which take place within us - such as individual thoughts, or complete thought processes - which interact constantly with the outer events.

Now we are able to observe these processes, both inner and outer, without being too easily identified with any type of event or circumstance. One of the lessons we hope to learn in these further stages, which are stages of Self-awareness in the search for Self-realisation, is how to choose. For this we shall need a clear and watchful intellect, which can only be so if we have ceased to identify with it.

Stage Thirteen, Death

Before we can set out to tackle the higher levels above Tiphareth, we must establish a sound feeling base to balance the intellect. In this stage, therefore, we look back toward Netzach and stage seven.

The feeling based person, as distinct from the intellect based person, senses the significance of the change which takes place when Self is discovered, and while we are at the lower level, such considerations can arouse the unconscious aspects of life at which most of us prefer not to look. We fear them as unknown, and associate them with a kind of death. To reach Self from feelings involves wandering among these unconscious elements, seeming to pose a real threat to consciousness itself, a walking through the valley of the shadows. We now see that we have, after a manner, experienced death of a kind. The person we were before is gone forever, and although traces may remain, we can never return to that person and identify with personality as we did before. We are not feelings; we *have* feelings. By making conscious use of feelings and thoughts through awareness of Self we can use the personality in the service of later stages.



The death symbolism is two-fold here in the same way as the previous card; were we to slide down this path and re-identify with feelings, it would be a kind of death to our newly-awakened awareness. Some Christian symbolism is described as seeking "salvation" (Tiphareth in Kabbalah) from the direction of feelings in stage seven. Likewise, the concepts of "rebirth, wrestling with sin, death and the devil" often take this approach. But personality in stage seven, or for that matter any of the lower stages, is incapable of doing these things. It can only affirm the intent and devotion to the ideal. The battle against evil can only take place from the level of Self, where the individual is with and in "Christ," and "Christ" is in the individual. "Christ" comes from the Greek word, 'to anoint' (as does "Messiah" in Hebrew) so that to be "in Christ" is to be in a state of spiritual anointing. "Christ in us" is simply one way of saying that we have received a spiritual anointing from a higher Source.

Netzach is one step higher up the Tree of Life than Hod, and is the nearest we come to Self from the lower stages. Also Netzach receives an influence direct from the central Tiphareth, coming down the lightning flash. Truth has not passed through so many filters, and the feeling based person seizes upon feelings as a means to Self-discovery more readily than the intellectual, who has to analyse and classify

truths before acknowledging them. The drawback for the feeling person is, of course, that the intuitional perception of truth does not exempt anyone from development of the intellectual aspects of personality in order to balance and understand experience. The Self-aware person, looking from Self at the feeling nature, is able to realise that, close as feelings are to true Self they are still only a possession, and an equal part of personality together with the other parts. The card “Death” now symbolises the possibility of ascendancy over fears of death, for when we have found Self we are open to contact with Spirit.

The clarity that Self-awareness brings can, as we progress, make the unknown known. We can discover that we are both immortal and eternal. The body dies; but we are not bodies. We *have* bodies, that is all. They are the means whereby we are able to localise awareness in this world and to gain experience.

We may now start out towards the first of the deeper levels beyond Self, in which Self has its being.

Stage Fourteen, The Angel, or “Temperance”

We now prepare to set out, gloriously Self-aware, towards the level of desires. “Desires” here speaks of the most deeply rooted needs of our being, having nothing to do with what we like or dislike, which is an aspect of the feeling-nature of personality in stage seven. The card portrays an angel pouring water from one cup into another. It is a card of beauty, and the angel has great sweeping wings. It is maintained that death does not change our fundamental being, and we shall discover that becoming Self-aware does not change it. It does change much of what we possess (although not all of that, as we may be ruefully aware). The change that has taken place on reaching Self-awareness is that we now live from Self, being able to use our personality instead of living from it, subservient to its impulses.



Our basic nature is not changed, and becoming Self-aware only shows us more clearly what we are fundamentally, for good or evil. By far the largest problem, and probably the only real problem which confronts us in living from Self is pride, the vice of Self, and the only “original” sin. It is natural for us to be proud of our achievement, and to see that we are eternal beings with a heritage of truth. The image is true, so far as it goes, but we must put our heritage to good use, however eternal the soul, and we are not angels - yet.

The figure on the card pours water from one vessel into another - a somewhat futile procedure. We cannot hold on to what we have, and simply enjoy our new capacities to our own advantage, for we have to learn that this is not the function of the human being in the world, even though we see so many doing this. The Tree of Life does not end with Tiphareth, but with Malkuth. The work we have undertaken leads eventually (for those who can go this far) to an understanding of how we may bring the spiritual element into the affairs of Earth. For this reason, a path is shown on the card leading either to or from the light (in the Waite pack). The choice is our own. Its successful conclusion is the taking of Step Five.

Stage Fifteen, The Devil

The level at which desires operate can be quite terrifying. Beyond the level of Self-discovery we begin to come into close contact with deeper forces which motivate not only ourselves, but whole armies of selves, and entire departments of nature. Pride may tempt us to identify at a Self level (unfortunately this is quite possible) and claim these energies for our own. We are apt to say, “My desires,” but this level belongs at the same time to all of us and to none of us. The levels of instinct, intellect and feelings also belong to all, but these are levels of personality, functions of being, and are in fact reflections, in the personality, of Self. Above us are deeper levels of Self, and levels beyond Self. The possessive pronoun “my” properly belongs to personality and has no real place among the qualities of Self, nor may it properly be applied to Self. So long as we cannot discriminate at the level of desires, so we are chained to desire, as are the unfortunate couple on the card, who are chained to a stone upon which sits the devil. So long as the fires generated by desire can engulf us, we have cause to be afraid.



The devil has no objective existence, as popular myth would suppose, but represents the peculiarly human tendency to humanity’s worst vices, hence cruelty is assigned here. In the Semitic languages from which the concept derives, “evil” is understood as the evil disposition in human beings.

If therefore we pray, “deliver us from evil,” then the Aramaic-speaking people who gave us this prayer would have understood it in the sense of “separate us from [our own] evil inclination.” According

to psychology, one of the most common methods of dealing with fear is to explain it away, and here we may be tempted to do this.

Intellectualising, however, does not work above Tiphareth, for we have to know what we are; what we may safely do with such power as we find at this level of being. Yet the Sephira Geburah, which is related to this stage (and Step five) is representative, at the higher level, of the Sephira Hod, below it on the Tree of Life, which is its reflection, and called the sphere of intellect in stage four.

Stage fifteen, however, requires a much higher degree of this principle, which has been spoken of as watchfulness. It also represents the faculty of reason - not the same thing as intellectualism. To understand this level and function according we need to be able to hold our awareness - our Self awareness - still, unmoving, letting the forces flow around us, so that we may know them for what they are without being swept along by them into situations which we cannot control. Mostly by this time we are able to control our reactions to outer events quite well, and it is the inner situation which requires our attention. Attention - we need to attend, to be watchful. Attention - we need to attend, to be present.

At this stage may find that life will present us with considerable temptation to demonstrate how holy we have become. Also, we shall see that life will present us with truly “diabolical” situations; situations where we must choose, yet at the same time where we seem to have no choice at all. Only those who have seen something of this level can fully appreciate this, for the conflict that rages here rages within the soul and has little to do with outer circumstances. These merely throw us back on ourselves - possibly very hard, but no harder than we should be able to deal with. At this stage, we begin to look for the deeper level of being which transcends Self, and we begin to appreciate that we are terrifyingly and wonderfully not Self, but Spirit.

On the scale of the Ladder this stage is represented by Path 21:

“The Rewarding Intelligence. It receives the divine influence, and influences by its benediction all existing things.” Now there’s something to think about . . .

Stage Sixteen, The Tower

This card, like some others, has a double significance. The images on the card show clearly the effect that occurs if we presume to claim deeper forces for our own, instead of seeing their influence working in us and through us, instead of coming to terms with them and working in line with them. If we persist in holding on to cherished notions which have little relation to reality and truth - both inner and outer truth - we shall find that life will knock us hard, and even harder, until any false positions we attempt to maintain (from pride) are *seen* to be false. The truth, however unpalatable, has to be accepted. It is only the top of the tower which falls, and it is only our pride which will be hurled down by the lightning flash. The rest of the tower is intact. This is one way of saying that however hard we may seem to be hit, it is only our identifications which have to go. The work we have done up to this stage cannot be undone and we remain Self aware beings, if somewhat wiser.



It can happen, however, that unable to relinquish our identifications, we find ourselves going down the path that joins Geburah and Hod, landing back at stage four, except that we bring with us the power of Self. We could in this state become quite formidable intellectuals, but the energy which gives this power is misplaced, and although we may have excellent Self control, we are in an unbalanced condition, as there is no equivalent power for our feeling nature in Netzach to use. If, in such a state, we are to continue, we shall need to circumnavigate the whole of the lower triangle of personality once more, distributing the power of Self among the attributes of personality, so that we may climb up again from a firmer foundation. If, however, we are able to avoid such identifications, we can set out towards ‘Hesed, via stage seventeen.



Stage Seventeen, The Star

This card shows a naked woman, representing the soul, with a brilliant star shining in the background. Like the angel of card fourteen, she has two vessels of water, but unlike the angel, she is pouring one on the earth and the other into a pool. Gone are the glorious trappings of card fourteen. Here we must be as we are, not as we would like to appear. This stage shows the beginning of Self-realisation. Devoid of trappings and identification and attachment with lower levels, relatively humble, we are able to use in a constructive manner the truth we have been given. Some of the water is poured upon the ground. That is to say that we may use what has been given to us outwardly, in the world.

The rest of the water goes into a pool. That is to say that we also apply truth inwardly towards higher and deeper levels, allowing it to work within us in the same way as the water poured upon the earth may work outside of us.

The star of Kether shines in the background, and intimations of Spirit are strong, in the same way that the star of Tiphareth shines behind the lovers in stage six, where intimations of Self are strong.

We still have much to learn at this stage, except that we begin to learn by doing, with less emphasis on watching, which should now be second nature to us. Here we begin to be open to spiritual energies, and to transmit them to those behind us on the Way.

Stage Eighteen, “The Moon”

Both this card and the card which follows it are misnamed in this arrangement. The significance of card eighteen has to do with the card as a whole, and if we compare the symbolism with what we know of the Sephira ‘Hesed with which it is here associated, we shall see that it presents highly relevant symbolism. This is the level of origins. A primeval creature crawls out of the waters. Two ancient stone pillars stand silent in the landscape, flanking a pathway, well trodden but primitive, leading to a far off place. Two hound-like creatures are howling at the moon, apart from which all is still as night. Here are the roots of the elements and the roots of physical form. Here, we meet the passive but powerful mind aspect of nature. Here, we are in contact with the power of mighty Mother Nature herself, and subject to her dominion.

Here, we come to terms with natural law and find our place within it. This level, like the one before, will not allow us to identify with it nor to claim it as “mine.” If we attempt to do so, then we shall be subtly but firmly removed to a lower place to learn differently. Natural law surpasses human laws and conventions. Human laws are only workable so long as they are in accord with it. Human law may legitimately restrict the movement of nature in ways which are in keeping with the needs of a time or place, but it cannot countermand natural law. We can place buckets in the rain to restrict the flow of water upon a particular spot, but we cannot stop the flow and, if the rain is heavy enough, no amount of bucket-placing will prevent the ground from becoming soaked.

Here we learn to bend with the wind, like a blade of grass, to go, consciously, where it is necessary for us to go, and to do, consciously, what it is necessary for us to do.

On the scale of the Ladder, this stage is represented by Path 20:

“The Intelligence of Will. It prepares all created beings, each individually, for the demonstration of the existence of the primordial glory.” Wow!



Stage Nineteen, “The Sun”

As with the previous card, there is more here than just the sun which forms a part of it. Here we see what may happen should the feeling which this level arouses cause us to identify with the forces of nature. We are in danger of slithering into a warm “summer” glow, returning, blissfully unaware of what is happening, to stage seven. Lulled, perhaps, by a false sense of security (due to pride) in the presumption that we have conquered nature. The fall, though gentle, and not at all disruptive in the way that card sixteen depicts, is every bit as devastating.

We will bring to the level of feelings in Netzach all the power of Self, finding that we can appear to sweep away obstacles almost by wishing them gone. But this is the other side of the coin shown in card sixteen, and in the same way we shall have to go round the lower triangle once more to re-establish our equilibrium.

In the tarot card this is shown by the soul, in the form of a child, being carried by the horse, representing the forces of nature. The rider has no reins to guide the horse, and goes where the horse takes it. The light of Self is left behind on the other side of the wall, although it still shines over it as does the sun on the card. The lesson here is to be able to move with natural forces without being carried away by them.

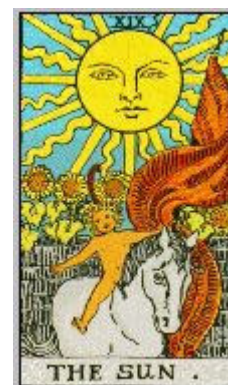

Stage Twenty, Judgement

This card portrays the angel of judgement calling forth the dead from their graves, symbolising the last stage before we complete the realisation of Self. *The judgement which is made is the judgement which we make upon ourselves.* All loose ends are tied up here. Any remaining problems are dealt with. All buried impulses, identifications and attachments are brought to light. Our house is put in order. In this stage we can walk through the valley of the shadow without fear, dealing with each ghost as we meet it, integrating what we find in the deeper levels within us, and whatever we receive from higher levels above us, and emerge at the other end of the valley whole and complete, entering into the state of grace which is called here Self-realisation. This stage is equivalent to stage nine of personality development shown by the Hermit, but at the higher level of Self. Here we complete our Self foundation in order to take the step towards Spirit, as in stage nine we prepared the ground to take the step towards Self.



Stage Twenty-one, The World

Our journey is almost complete. We have built our foundations and are able to stand in direct contact with the power of Spirit, ready to become spiritual beings when we are called from the other side of the Abyss. At this stage the meek truly inherit the earth, and we can become a direct channel for the power of the Spirit.



STEP ONE Centred on Yesod

The first three steps are steps of personality, as are Stages one to ten. The remaining steps are steps of Self and Self-awareness. The first stages in Step One are taken once the Awakening has begun. These are represented by cards 0 to 3. In the beginning stages up to Stage Ten we are attempting to build personality into a stable foundation upon which the greater awakening to Self and Self-awareness may be begun. The first Step is the beginning of a Foundation upon which we build our understanding on the journey towards Self-awareness, Knowledge and true Being. As a result of a certain amount of preparation in life, the desire is stimulated towards Spirit. This first step opens the Way towards freedom, independence and self-expression. Yesod is the ninth Sephira on the Tree of Life. **Its virtue is Independence; its vice, idleness.**

In astrology, Yesod is represented by the Moon. At Step One our level of being is governed by and related to the anterior pelvic plexus, governing the organs of generation, whilst the posterior pelvic plexus, governing the organs of evacuation, may be referred to Malkuth. In the chakras of the subtle body, these are represented by the *svaddisthana* and *muladhara* chakras respectively. At this level, our minds tend to be dominated by sex and materialistic considerations. In the quest for realisation this step is the arising of the right desire, or right impulse, the starting point which leads on to Step Two by means of good intention.

STEP TWO Centred on Hod

The second step of the Way is where we come to a decision, through reasoning, concerning the desire for real freedom. Here we apply the intellect to the matter of growing towards spirit, and we adopt or discover a system to follow. Hod is the eighth Sefhira on the Tree of Life. *Its virtue is Truthfulness. Its vices are Falsehood and Dishonesty.*

In astrology it is represented by the planet Mercury. Here we have no doubt about the Way, for it is in line with our intentions and conviction. We have realised that we can go further.

In the second three stages during step two, we are strongly affected by the “vital” or “vitality” energies of Nature, sometimes considered to be analogous to the *prana* of Eastern schools. In the subtle body it is represented by the solar plexus, a little higher than the navel, and is called the *manipura* chakra.

In common with the psychologist Jung, it is important to mention that purely Eastern systems of development are unlikely to be suited to the temperament of people in the West. Jolande Jacobi, in *The Way of Individuation* (Hodder & Stoughton, 1967) tells the story of a Western man who spent six years in an Eastern monastery, but had to leave as he could not find what he needed. On his departure he was given an exquisitely wrapped gift. When opened, it proved to be a beautifully bound Bible.

The level of being in Step Two is basically that of Step One, except that we are now better able to appreciate the nature of the human personality.

STEP THREE **Centred on Netzach**

The third Step of the Way. During this stage, continual help is being received from outside influences. Here begins to be formed within us a centre from which we may build permanently in order that Self may become manifest in us. The glamour of, and attachment to possessions is very strong. We need to cultivate humanity and humility. Netzach is the seventh Sefhira on the Tree of Life. *Its virtue is Unselfishness; its vices are Selfishness and Lust.*

At this point, we must make a definite effort to realise the nature of love, represented in astrology by the planet Venus. The level of being at Step three is basically what it has been since we began, except that we now begin to develop a conscious desire to raise our level of being to a more permanent state, developing the heart centre, or *anahata* chakra as we proceed.

STEP FOUR **Centred on Tiphareth, Founded on Yesod**

The awakening of Self. The Fourth Step of the Way. Before this can become permanent, there is a time of preparation and testing. The voice of Self is heard, the impulses of Self become known, and we are gradually given the opportunity to see ourselves as we are. The rest of the journey will need all of our qualities. If we continue further, we can be united after Step Four in a manner not easily described. Having permanent centres, these centres are linked in Eternity, and we are truly “members, one of another.” Tiphareth is the sixth path on the Tree of Life. *Its virtue is Devotion; its vice is Pride.*

In stage ten, we have our being in the region of the solar plexus in the body, there being continual interplay between this centre and the lower plexi. At the same time, we begin consciously to receive impressions from the heart centre which flow downwards and evoke a response.

In Step Four our centre of being is transferred to the heart centre. We get the first real glimpses of spiritual awareness and the warmth of spiritual love. This has been described as a change in our centre of gravity. After such a change, we can never be the same again.

STEP FIVE **Centred on Geburah**

The fifth step of the Way. Here we begin to see the activity of Spirit in every manifest thing and see that they are, because of Spirit, not many things, but one thing. Not many lives, but one life; a life that is common to all creation. Here we see this; we have yet to know it. Here lies the strength of Spirit, and the weakness of humanity, shown by the cruelty of pride. This pride is generated by attachment to the things of Self, by identification with that centre in us which is necessary for us to be able to continue, formed at the fourth Step of the Way. *Its virtue is courage. Its vice is cruelty.*

At this stage we still have our being in the heart centre, and develop insight. We begin to see ourselves and things as they really are. We realise about things what they are, how they are constituted, and observe their properties. Also we begin consciously to become aware of the attraction of Spirit, which informs all that is. Geburah is the fifth Sefhira on the Tree of Life.

STEP SIX

This Step completes the balanced triad of Tiphareth, Geburah and 'Hesed (in ascending order). Our centre of being becomes more firmly rooted in the heart centre, and a serious awareness of spiritual love begins to manifest itself towards us. It is very well described by the text of Path Eighteen. 'Hesed is the fourth Sefira on the Tree of Life.

Its virtue is obedience (to spiritual law); **its vices are hypocrisy, bigotry, gluttony** (thinking we know better ...)

STEP SEVEN

The seventh Step of the Way. Here we may begin to manifest Spirit directly, for we are one with Spirit, and we are Spirit. This is the fourth state of awareness beyond which lies, on the other side of the Abyss, the worlds of Spirit.

Those who have progressed this far may, in this life, take the position of Knowledge (Daath) from time to time, and in Knowledge of Creation may give this knowledge, given first to them by the Spirit, to others on the Way following.

On the scale of the Ladder stage 21 and Step Seven are represented by Path 19:

“The Intelligence of the Secret of all the Spiritual Activities. The fullness which it receives derives from the highest benediction and the Supreme Glory.”

Two centres in the subtle body are affected by this Step. One is the throat centre, governing the organs of speech, and the other is the centre in the region at the back of the head, sometimes associated with that part of the body where the nerves from the left and right hemispheres cross over as they move downwards through the body. Via this centre we may, under certain circumstances, receive instruction from “higher” or “inner” planes and intelligences such as are described in (for example) modern theosophical writings as “Masters.” In the Hebrew mystery tradition they are known as *Maggidim*. Other systems have other names for them, but all systems refer to them in some way or another. In biblical literature they are the “angels” - or spiritual messengers.

COMPLETION

When we finally cross the Abyss, (i.e., at the time of physical “death”) we shall be in another world, and another life, ready to start out upon another, higher Way to another higher destiny which is our true inheritance. This next world is the world of Briah or Creation, the “Third Heaven” of the apostle Paul, the “Paradise” or “Garden of Eden” which Jesus is reported as having told the thief on the cross they would soon be sharing. We may have brief excursions into this region while in this life, and experience which Paul describes as seeing, “as in a mirror, darkly.”

“Spiritual friend in God, thou shalt well understand that I find, in my boisterous beholding, four degrees and forms of Christian living: and they be these, Common, Special, Singular, and Perfect. Three of these may be begun and ended in this life, and the fourth may by grace be begun here, but it shall ever last without end in the bliss of Heaven.”

(Adapted from “The Cloud of Unknowing,” edited by Evelyn Underhill (London, John M. Watkins, sixth edition, 1956). The unknown author of this work places the four worlds with which we are by now familiar in ascending order, from Common (Assiah) to Perfect (Atziluth). A comparison with The Ladder in Part Three following will be found to be most enlightening. The “third heaven” and its attributes as described by the Christian apostle Paul would equate very precisely with the third or “Singular” degree appropriate to the world of Briah.

PART THREE

THE THIRTY-TWO PATHS OF WISDOM and the *SEPHER YETZIRAH*, or Book of Formation

PREFACE

*This work includes a combination of an abridgement on the one hand, and a conflation on the other. In the Kabbalist working model or diagram of the Ladder, it has previously been ascertained that the text of the work known as the **Thirty-two Paths of Wisdom** depends for its practical application upon the order of the letters as given in the ancient source work, *Sepher Yetzirah*. What has been attempted here is to bring the two texts together in a relatively simple and meaningful way so as to aid the student who wishes to investigate matters further. Both texts are full of superlatives with respect to the deity, or*

THE SYMBOLISM OF THE CHRISTIAN CHURCH

In each of the four worlds (Atziluth, Briah, Yetzirah and Assiah) it is possible to draw a single Tree of Life in the conventional and simpler format. In consequence of this it follows, owing to the arrangement of the Ladder, that a Sefhira in one world may be a different Sefhira in another, relatively speaking. Where this occurs it has been noted in the individual texts of the 32 Paths.

Other attributions included with the text are derived from *Sepher Yetzirah*, and an edited version of this work is included in order to show how the attributions are derived.

The important thing to realise is that the attributions are **not** a modern invention, but follow logically and consistently from the arrangement described.

As will quickly be seen, the texts of the 32 Paths are concerned with matters spiritual, and it is to the spiritual life that the work of the true Kabbalist is, and always has been directed.

This is not to say that the material life is of no consequence. The way in which we conduct our affairs in this world and this everyday life is as much a part of the spiritual work as the deepest meditation or the highest contemplation, whether that work is based upon traditions of Judaism from which Kabbalah derives, or upon later Christian traditions which gratefully received it. In discussing the origin of the Christian Eucharist, one scholar remarked that not too much could be made of the sacredness of a particular Jewish meal, such as the Passover, as every meal is sacred in Judaism. In the same spirit, we need to remember that all of the Sephiroth and all of the 32 Paths are Holy. **All** are Paths of Wisdom. The word for Wisdom, both in Hebrew and in Greek, is feminine, and appears as a "saint" in the Christian tradition as Saint Sophia. This is how we may wish to understand the true mystery behind the expression, "Mother of God."

"JACOB'S LADDER"

The main tributary of the stream of Kabbalist Teaching in the western world of the twentieth century has for many years been fed by the work of the Hermetic order of the Golden Dawn, its successors and its imitators. Today's students are indebted to this work, but the river has broken its banks, and we find that although many people know a great deal about Kabbalah, not so many know what Kabbalah is about.

The inspired Freemasons of the Golden Dawn, while passing on to us the important and vital elements of the Teaching, also passed on their own inspired guesswork, which coupled with an apparent love of secrecy for its own sake, left a number of "deliberate blinds" and attributions which do not fit the facts, distort the tradition, and do not make sense. Even so, they have performed a valuable service in that they have made us look for the facts, the tradition, and the sense, which otherwise we might not have done.

Faced with the teachings of a profound study to which has been added confusion, uncertainty, and misinformation, the best means of establishing the truth is by reference to an earlier source than the polluted tributary. One of the earliest Kabbalist works is the Hebrew *Sepher Yetzirah*, rendered by Friedman as "Book of Creation." Some study of Hebrew as a language soon shows that Friedman, like the "adepts" of the Golden Dawn, has taken a small but serious liberty of his own.

"Book of Creation" would need to be a translation of "Sepher Briah." Although we could say that we are talking about creation, which is partly what Kabbalah is about, it is not about magic, self-seeking (in the ordinary sense) or personal aggrandisement. The word *Yetzirah* is best rendered as "Formation" - in other words, not what is created, but how, and the work is usually known as the "Book of Formation," which is a correct translation from the Hebrew.

Faced then with confusion and contradiction, what does Kabbalah say of itself? According to *Sepher Yetzirah*, creation as we know it is emanated via thirty-two paths of wisdom, involving ten Sephiroth, or numerations, regarded as principles of development, to which are added the twenty-two letters of the Hebrew alphabet (Kabbalah having its origins in Israelite religion). It is clear that the Golden Dawn understandably, but incorrectly, supposed that 10 plus 22 being 32, the first ten of the 32 paths related to the Sephiroth, and the remainder to the Hebrew letters, a supposition which is not reinforced by the text of *Sepher Yetzirah*. Some pre-Golden Dawn representations of Kabbalah's "Tree of Life" show an arrangement of twenty-two paths or connections between the Sephiroth on the Tree, which while satisfying the required quantity, do not satisfy the enquiring mind, nor appear to have any real *raison d'etre* other than perhaps to prevent the Sephiroth from dangling in space, a problem easily solved by joining them in their given order of development, and thus producing the well known appearance of a "lightning flash" and described as such in the *Sepher Yetzirah*.

Having also available the text of another Kabbalist classic which gives a separate description of the thirty-two paths, the Golden Dawn assigned the first ten to the Sephiroth, and the remainder to twenty-two paths nowhere described as such in the *Sepher Yetzirah*. In order to be consistent, an examination of the internal logic of the diagram which shows these paths makes it plain that there would need to be not 22 but 24, for there are no paths shown between the 2nd and 5th Sephiroth or the 3rd and 4th. The absence of the latter means that there is no route in such an arrangement for a “lightning flash” to follow, which is absurd. Be that as it may, and allowing for some mystery to explain the omission, the Golden Dawn then allocated to these paths the twenty-two Hebrew letters. While this arrangement shows a kind of logic, it is not the logic of the Teaching.

As an example, the first of the 22 letters was assigned to the path between the 1st and 2nd Sephiroth, and the second letter to that between the 1st and 3rd. As the teaching of Kabbalah requires that the development of the Sephiroth follow the natural order 1,2,3, we are bound to ask how the path from 1 to 3 comes into being before that between 2 and 3? And why is there no “path” between 3 and 4? It might be argued that there are other natural progressions than that of a simple series, and the *Sepher Yetzirah* employs a different order for the letters of the Hebrew alphabet than a purely alphabetical one. However, the Golden Dawn did not use the order given in the *Sepher Yetzirah*, but assigned the letters in simple alphabetical order to an illogical arrangement of paths inconsistent with the text.

In order to resolve the problems thus created, we have referred to the source material of the *Sepher Yetzirah* and the text of the Thirty-Two Paths of Wisdom. We have followed the sense of the *Sepher Yetzirah* and arranged the 32 paths in the order of a lightning flash. As the arrangement of the known universe appears to be built upon a foundation best described by the mathematical factor, pi, the resulting diagram is built upon a succession of overlapping consecutive circles. In having done this we find depicted ten overlapping spheres or Sephiroth, a point emphasized in *Sepher Yetzirah*, which states most positively that there are “ten and not nine, ten and not eleven.” We also find that the text of the Thirty-Two Paths of Wisdom becomes less cryptic. The text of path 10 for example states that it “has its seat in Binah.” Reference to the Ladder of the 32 paths shows that it does just that. We also find illustrated the doctrine of the three “veils of negative existence” and the four Kabbalist worlds.

Proceeding from this base to the text of *Sepher Yetzirah* itself, a consistent arrangement is developed which admittedly needs further research, and it is to be hoped that the distribution of this work will stimulate students to undertake the task. It was first thought that *Sepher Yetzirah* should be regarded as a commentary on all 32 Paths of Wisdom. While this was a natural assumption, it also proved to be superficial. On examination of the various attributes described in the *Sepher Yetzirah* it fell out quite naturally that these attributes came to a full stop at path 28.

This created a momentary puzzle until (referring to source) it was realized that the title of the work itself provided the solution. Path 28 is the final point of the development of only the first three worlds of Kabbalah, and thus the final point of the world of Yetzirah from which the book takes its title.

In assigning the letters of the Hebrew alphabet, the order of the *Sepher Yetzirah* has been followed, which classifies them not alphabetically, but in the order of three mother letters, followed by seven double letters and twelve simple letters. The arrangement of seven double letters also follows the traditional arrangements of the seven planets of the ancients. Furthermore, when these planets are placed on the diagram of the Ladder they are seen to conform, in their double rulership of astrological signs, to the traditional and natural arrangement of the astrological “wheel.” The assignment of the signs of the zodiac to the twelve simple letters demonstrates a similar consistency.

In chapter three of *Sepher Yetzirah*, the three mother letters are mentioned again in more detail, with a repetition of the concept of six permutations as conceived in relation to the divine name (YHWH). Individually however, they are referred to spirit, water and fire respectively, also referred to much earlier, in chapter one, to paths 1, 2, 3 and 4. This results in the curious allocation of the letter Aleph to both of the first two paths, the letter Mem to the third, and the letter Shin to the fourth. That there is a puzzle here is self-evident, and *Sepher Yetzirah* seems at pains to point this out when it mentions the three simple letters “holding the secret” of the three mothers. In the meantime, we have a wealth of material to consider and develop, the skeleton of which now follows. It is to be hoped that new and later generations of students will put flesh on these bones, and in emulation of Genesis breathe the breath of life into the body of the teaching.

(The above was written in 1977. Since then it has become apparent that the three mother letters, Aleph, Mem, Shin, should be assigned to paths 7, 8, and 9 respectively).

THE EMANATION OF THE FOUR WORLDS

It will be seen from the diagram Ladder that this process of emanation is begun in the Major Sephiroth at Path Four (in the case of Kether). With the development or establishment of a centre to any

Sephira, the seed is sown at the same time for its successor. Not so immediately obvious is that this applies also to the four worlds. In Path Ten for example the centre of Binah is reached, and the seed of 'Hesed is sown. Creation as we know it begins.

Also, the centre of the highest world of Atziluth has been established in the downward flow of creation, and the world of creation called Briah is begun. Study soon shows that the principle of emanation is illustrated by the diagram of the Ladder, from Kether to Malkuth, and from Atziluth to Assiah.

FOUNDATION CARDS OF THE TAROT

In the downward attributions of the Tarot trumps certain cards fall in each of the greater Sephiroth, and in the minor Yesod position. In ascending order of the Ladder they are as follows:

Malkuth - "The World" - card 21, Path 32.

Yesod - "Judgement" - card 20, Path 31.

Hod - "The Star" - card 17, Path 28.

Netzach - "Temperance" - card 14, Path 25.

Tiphareth - "Strength" - card 11, path 22.

Geburah - "Justice" - card 8, Path 19.

'Hesed - "The Hierophant" - card 5, Path 16.

Binah - "The High Priestess" - card 2, Path 13.

Note that card 11 "Strength" falls in Tiphareth in both the minor and the major scale.

It can easily be seen that each Sephira is shown to be the source of that which succeeds it, namely: Hod is the source of Yesod, as the foundation of Hod is Path 28 "The Star" which becomes the central Path of the Sephira Yesod, and may be regarded as the ruling principle of Yesod. Here again, the Ladder is seen to illustrate the doctrine of the emanations, and the teaching itself.

The 21 Stages in relation to the Tarot and the Ladder.

The practical link between the Major and the Minor Sephiroth.

In the Seven Steps of the 21 stages these commence again in each world when the Daath position is reached, which would be analogous to a Step Eight except that Knowledge, being a function of awareness, is in reality the ultimate development of Tiphareth. So in theory there are 80 Steps to Path 10. In practice such an ascent is not possible. The practical limit for our progress in this life is the highest point of the greater Tiphareth: Path Sixteen, Kether in Yetzirah. The absolute limit is the Daath function of this in Path Thirteen, at the centre of the greater 'Hesed, touching at the same time the highest point of the greater Geburah, and the lowest point of the greater Binah, which shows the "link" across the Abyss of the Four-in-One Tree. In terms of the minor sephiroth this point is both Yesod in Atziluth and Daath in Briah.

The practical limit of Path Sixteen is represented in the minor sephiroth by Malkuth in Atziluth, Tiphareth in Briah, and Kether in Yetzirah. Those who understand will appreciate that no incarnate human intelligence can pass beyond Kether in Yetzirah without becoming discarnate. Hence, the Daath function shown in terms of Path Thirteen can only be a temporary state giving contact with the highest worlds of Spirit, in order to bring that Spirit back down through the worlds. This will give 21 Steps in all, plus the Daath function, which gives the basis for a study of the application of the Tarot and the Hebrew alphabet.

The Emanations.

Each Sephira is said to emanate from its predecessor. That is, the second Sephira is formed within the first, and so on, and is a natural development from it.

The Thirty-two Paths of Wisdom

The Thirty-two Paths of Wisdom constitute the framework from which this text has been derived. They are themselves the Keys to Kabbalah from which we have taken the title of the whole work. In this part therefore we show in some detail how the scheme of the Ladder is derived. For this reason this section is arranged in the order of the 32 paths, and describes the other attributions included under their respective heads. We have followed closely the translation of the original Hebrew given by A. E. Waite in *The Holy Kabbalah* and an abbreviated form of this translation is at the head of each section. All else will be seen to follow from this.

The Greater or Major Sephiroth.

It will be seen as the scheme unfolds that in the process of the development of the 32 paths according to the order of the “lightning flash” that ten and not nine, ten and not eleven Greater or Major Sephiroth are revealed. There are nine of seven Paths each, and one of five Paths. These are illustrated, and in some instances commented upon, as the text progresses.

The Minor Sephiroth in the Four Worlds.

Of the 32 paths, 29 are seen to correspond to positions on the scale of the four worlds, which unfold in a similar manner to the Greater Sephiroth in that each world arises from within its predecessor. These 29 attributions will be found to correspond with the version of the Ladder given in the works of Z’ev ben Shimon Halevi (Warren Kenton). It does not follow however that other attributions given by Halevi will also be found to correspond. Students are commended to make their own comparisons, and to find their own truth.

The Greater Tarot.

Commencing at Path Eleven will be found a different arrangement of the Tarot cards from that given in the section on the 21 Stages.

This demonstrates the subtlety of the Tarot, which first appeared at a time of persecution of the followers of esoteric teachings. Indeed, the internal evidence of the cards suggests that the important basics of the teachings were encapsulated in them in order to preserve it. Be that as it may, the Tarot cards are found to illustrate the Teaching on more than one level, which is why it is found that their symbolism is appropriate in more than one arrangement. Only two such arrangements are given here, but there are others, and these are also found to possess the same numinous quality.

Attributes of Sepher Yetzirah.

These should not necessarily be regarded as authoritative. It is true to say that no authority can be given to any teaching from the pages of a book. The first authority that a student can recognize is the authority that is found from personal experience. As to any higher authority, this ultimately rests elsewhere. Kabbalist tradition maintains that the teaching was originally given to humanity by the angels. It still is, and whoever seeks shall find.

The Christian Church.

In the two thousand years of the present era, this is an institution which has undergone many changes, trials and tribulations. It has been arguing with itself since at least the second century, and in our own day continues to do so while at the same time searching desperately for a means to unite.

However, the conflict is not between churches so much as between institutions, and the real problems are political, not spiritual.

The word church is taken from the Greek *ecclesia* which means community, and the “Church,” in the fullest sense of the term, properly refers to the community of believers. This church transcends sectarian differences. Many orthodox institutions would recognize this transcendence in principle, but in practice it tends to undermine a particular institution’s claim to be the custodian of the full truth. Yet the very structure upon which apostolic and catholic churches are built indicates to the Kabbalist that it must at one time have been built upon a familiar and similar foundation.

In the ancient catholic churches, in which must be included the Orthodox churches of the east, there were seven degrees of Holy Order. These are found to correspond directly with seven of the Greater Sephiroth of the Ladder.

In other words, the very structure of the Episcopal and Apostolic system is a direct reflection of the Teaching. Would it be too much to wonder if the early church was not perhaps a School of Kabbalah? Was it not, after all, founded by Israelite Christians? Before his conversion, the apostle Paul sat at the feet of the Kabbalist Rabbi Gamaliel. There are some who maintain that Jesus himself was trained in the Kabbalist schools of the Essenes. He certainly taught many of their doctrines. We cannot assent to this claim with much certainty, but there is enough to make us wonder. [See my later work, “*The Nazarenes - A Study in Christian Origins*”].

In ascending order of the Ladder the degrees of Christian Holy Order are as follows: Clerk or Cleric (a student degree); Doorkeeper; Reader; Exorcist; Acolyte; Subdeacon and Deacon.

There were no bishops in the modern sense of the term, and no priests in the early Church. The first ministers of the new religion were the deacons mentioned in the New Testament; the functions of

bishop and priest came later, the priest last of all. This would suppose a very early origin for such a "school" as early as the Apostolic age. For the present, it will be found that each of the seven orders is allocated to its natural place upon the Ladder, with such attributes as properly belong to the degree of Holy order in question, as described in the various ceremonies during which these degrees are bestowed.

THE MINOR SEPHIROTH

These are mentioned in the notes which follow, and a few introductory remarks are needed. The section headed "The 21 Stages of the Way" (Part Two) is intended to illustrate their use in practical development. The diagram of the stages shows an application to the Tree of Life in its more familiar form.

Other diagrams included in the present section show the same process as seen in each of the four worlds. Thus, each of the 32 Paths is also, commencing with Path Four, representative of one or more minor sephiroth in each world in turn. Comparison of these diagrams with the diagram of the Ladder will make this clear. Appendices One and Two show how the diagram of the Ladder may be condensed into a "Four-in-One" diagram, and show how the traditional diagram of the Tree of Life is formed from the teaching of the 32 Paths of Wisdom.

The Major Sephiroth Considered Individually

KETHER is half unmanifest and half in Atziluth.

'HOKMA is wholly and entirely in Atziluth, and is thus the first complete manifestation of Spirit. Hence we look to YH or YHWH, rather than AHYH.

BINAH is half in Atziluth, half in Briah. Binah heralds the first principle of creation, that of limitation, which cannot begin before Briah.

'HESED is complete in both Atziluth and Briah. This illustrates its function as the first Sephira of recognizable form.

GEBURAH is centred in, and is the central Sephira of Briah. At the same time, it is half in Atziluth and half in Yetzirah. It therefore illustrates the energy or impetus which brings the spiritual force of Atziluth through form (Briah) into formation (Yetzirah).

TIPHARETH is complete in both Briah and Yetzirah. It is the receptacle at the lower level which contains the Spirit brought down from higher levels.

NETZACH is centred in, and is the central Sephira of Yetzirah. At the same time, it is half in Briah and half in Assiah. As Geburah transmits the spiritual impetus through form into formation, so Netzach transmits form, through formations, into manifestation.

HOD is complete in both Yetzirah and Assiah. It orders the formations of Yetzirah into recognizable Assiatic forms - in principle. Almost anyone can climb this far up the Ladder with little difficulty.

YESOD is half in Yetzirah, half in Assiah. It is the means of translation of the ordered forms of Yetzirah into material shape. Note its association with the childbearing goddesses.

MALKUTH is completely and wholly in Assiah. The form is complete.

THE STEPS OF THE LADDER

In Kabbalah there are traditionally ten steps. As has been mentioned elsewhere, the system may be studied on three levels. The first level relates to the major Sephiroth individually. The second level is the intermediate level of ascent via the return of the lightning flash. The third level, with which we are more directly and most practically concerned, is illustrated by the twenty-one stages of the Way (Part Two). At all three levels, the Steps or stages of development are considered in ascending order on the Tree of Life.

Steps 1, 2 and 3 follow Malkuth, Yesod, Hod. At the completion of step 3 the centre of Netzach is reached, halfway into Step Four. This is a point of difficulty, shock or transition illustrated by path 27 of the Golden Dawn system and stage six of the twenty-one stages.

Steps 4, 5 and 6 follow Hod, Netzach, Tiphareth. At the completion of Step 6 the centre of Geburah is reached, halfway into Step 7. This second shock point is illustrated in path 22 of the Golden Dawn system and stage fourteen of the 21 stages.

Steps 7, 8 and 9 follow Tiphareth, Geburah, 'Hesed. At the completion of Step 9 the centre of Binah is reached, halfway into Step 10. This is the point called conception/death in Ouspensky teachings.

Step 10 follows 'Hesed only as far as the centre of Binah. (See the diagrams showing the breakdown of the Ladder). To complete this Step would be to become like Enoch, who "walked with God

and was not.” This point is illustrated by Path 13 of the Golden Dawn system, and stage 21 of the 21 stages.

Ten Steps are shown. There are however only seven complete Sephiroth involved, as all teachings, in their practical aspects, are sevenfold. (Compare the seven planets in the astrological esoteric system, the teachings of Theosophy, Vedanta, etc.)

THE THIRTY-TWO PATHS OF WISDOM

PATH ONE

The 1st Path is called the Mystical or Admirable מופלא Intelligence, the Supreme Crown. It is the light which imparts understanding of the beginning which is without beginning. No created being can attain to its essence. The First veil of negative existence, or no-thing.

Sepher Yetzirah: The Spirit of the Living God . . . Voice Spirit and . . . the Holy Spirit.

Correspondences: The first of three veils of negative existence. Spirit.

Commentary: “The Supreme Crown.” That is to say there can be nothing higher. It is the “light which imparts understanding of the beginning which is without beginning.” It imparts understanding, but it is not itself that understanding. The beginning without beginning is the Sephira Kether, whose first appearance out of No-thing (Ain) is heralded by Path 4. Path One is only the first part of the Greater Kether, and is unmanifest. It follows that as any created being is by definition manifest, “no created being can attain to its essence.”

In Freemasonry, said to be represented by the 33rd Degree.

PATH TWO

The 2nd Path is called the Illuminating מזהיר Intelligence. Exalted above every head, it is also called the second splendour. The second veil of negative existence, Ain Suph - without limit.

Sepher Yetzirah: Spirit from Spirit.

Commentary: From here is the first movement of the 22 letters of the Hebrew alphabet, of which Aleph is the first letter, combining with all the other letters in turn to form 231 “gates.” There are three mother letters, seven double letters, and twelve simple letters.

“The Crown of Creation.” It is therefore above Creation, which it illuminates, but creation out of no-thing has not yet occurred. It is therefore equally “exalted above every head.” It is above the central point of the Greater Kether, in which the process of creation is initiated. It is thus the second part of Kether, “The Second Splendour.” It is without limit; beyond limitation.

PATH THREE

The 3rd Path is called the Sanctifying מקודש Intelligence. The foundation of primordial wisdom, the creation of faith (trust). The third veil of negative existence, Ain Suph Aur - Light without limit.

Sepher Yetzirah: Water from Spirit.

Commentary: Faith (trust) is born in us by the activity of Spirit which unites, as in marriage, our individual wisdom and understanding in knowledge of divinity. Internal recognition of Holy Spirit is at work in us. If we understand this, then that understanding is evidence in which we can put our trust (faith). Here is the formless and void of Genesis.

PATH FOUR

The 4th Path is called the Arresting or Receiving Intelligence בוט . It arises like a boundary to receive the emanations of the higher intelligences which are sent down to it. Herefrom all spiritual virtues emanate. (This path establishes both the centre of the Greater Kether and the first point of the first of the four worlds, the world of emanation, or in our terminology the spiritual world or “Heaven” of Christian theology.)

Sepher Yetzirah: Fire from Water. The Throne of Honour; Seraphim, Auphanim, the Holy Living Creatures, the Angelic Servants. The three mother letters held in the secret of three simple letters of the divine name.

Commentary: Kether in Atziluth. While Kether means crown, it is not the supreme crown, but the point of the centre of the circle whose centre is nowhere and its circumference everywhere, or vice-versa. It is the first “crystallisation” of anything whatsoever from out of no-thing, from out of the great unmanifest which is veiled by three veils; hence “it arises like a boundary to receive the emanations of the higher Intelligences.” Path Four is also the centre of the Greater Kether of the Ladder, which comprises the first seven of the 32 paths.

“It arises like a boundary to receive the emanations of the higher Intelligences.” That is to say that the “negative existence” - being, but being in no-thing - concealed by three “veils,” causes there to emanate a point, called Kether in Kabbalah, “The Primordial Point,” referred in the four worlds to the “minor sephira” Kether in Atziluth.

Path Four is the fourth part of the Greater Kether, and by its emanation, “all spiritual virtues emanate by way of subtlety, which itself emanates from the Supreme Crown.” The Supreme Crown is Ain, no-thing, the first Path, the root of “negative existence” or the unmanifest. Hence the point which “arises like a boundary” to receive the higher emanations represents the “creation out of nothing” familiar to theology. A comparison can be made with eastern thought. Such a study could throw light on the mystery of “non-being” in such teachings.

The world of Atziluth or Emanation, corresponding to Heaven in Christian theology, commences at this point. Path Four is the first concentration of positive existence. It follows that there can be no movement in creation until this arising occurs. While Kether is the Crown of Creation, ‘Hokma is the first principle of energetic creativity, as described in Part One, and may be considered as the principle of undifferentiated energy within manifest Creation. The text of Path Four states that “herefrom all spiritual virtues emanate by way of subtlety.” The Hebrew root of ‘Hokma, Wisdom, is the first three letters of this word, and taken alone without the final Heh, is translated “subtlety.”

The conditions necessary for the development of the Greater Sephiroth by way of emanation are implicit from the first moment of creative activity heralded by Kether in Atziluth. We can see from the Ladder that as well as being the fourth part of the Greater Kether, this Path is also the first part of the Greater ‘Hokma, and we find illustrated at the beginning of our study the doctrine that each sephira contains that which follows it in the order of emanation. It also follows that all ten sephiroth are ultimately contained within the Greater Kether, and constitute a unity with the Supreme Unity, the Supreme Crown. (Experienced students will find it useful to consider the seven Paths of each Major Sephira as representing its “Daath to Yesod” order).

In Freemasonry, said to be represented by the 30th degree, or “Knight Kadosh”

PATH FIVE

The 5th Path is called the Radical or Rooted Intelligence נשרש and emanates from the depths of the primordial wisdom.

Sepher Yetzirah: The height. Yod, Heh, Vav.

The Minor Sephiroth: ‘Hokma in Atziluth.

Commentary: Wisdom in Heaven. The Fifth Path, the second part of the Greater ‘Hokma “emanates from the depths of the primordial wisdom,” the foundation of which is said to reside in the Third Path, according to the text. To refer Path Three to the Greater Binah, as used to be taught, is absurd, for how can the third be the foundation of the second, from which it emanates? ‘Hokma, the second sephira, means Wisdom. In the arrangement of the Ladder the foundation of the primordial wisdom is not Binah, but Ain Soph Aur, a part of the unmanifest side of the Greater Kether, whence originate all qualities. Wisdom itself, as distinct from its foundation, is of course the Greater ‘Hokma. Considering Path Five as the second part of this Greater ‘Hokma, as well as being ‘Hokma in Atziluth on the scale of the four worlds, it is plain that Path Five does indeed “emanate from the depths of the Primordial Wisdom,” the Greater ‘Hokma, for not only does it form part of the Greater Sephira, but as has been said, is also ‘Hokma in Atziluth.

PATH SIX

The 6th Path is called the Mediating Intelligence, or the Intelligence of Separated emanation, שפע נברל communicating the multiplicity of spiritual essence to all below.

Sepher Yetzirah: The Depth. Yod, Vav, Heh.

The Minor Sephiroth: Binah in Atziluth.

Commentary: Understanding of Heaven. The sixth part of Kether, “The flux of the emanations is multiplied therein.” Binah is called the “Great Sea” and “Supernal Mother.” Also, Binah is symbolised by the triangle, and shadows forth the first possibility of containment, informed by the Radical Intelligence of

‘Hokma in Atziluth, Path Five. Until this first possibility of limitation and confinement there can be no means of multiplication or reproduction, for all energies emanated so far are dispersed throughout infinity, in Eternity.

Until this Path is emanated there can be no time. We cannot unite, as we are, with the infinite, and Binah in Atziluth represents the highest principle that may directly affect us, for it posits the finite, (wherein the flux of the emanations may be multiplied) and communicates the spiritual essence to all below. Note that this is *communicated*. That is to say, we do not ourselves attain this Path, although we receive its benefit. We are spiritually united with the reflection in Creation of the higher principles.

The third part of ‘Hokma, it is significant that the first three parts of the Greater ‘Hokma are also the first three Sephiroth in Atziluth.

In view of what has been said, it is not surprising that the Greater ‘Hokma should occupy such a unique position, for it is from this level of the conventional “Tree” that the possibilities of finite creation most directly emanate. Kether is only half manifest, as is clear from the arrangement of the first seven Paths, and the manifest part of the Greater Kether is also the first part of the Greater ‘Hokma. We are told that each Sephira contains the essential nature of the Sephira which follows it in order of emanation, and it is observable from the arrangement of the Ladder how this is depicted there, for as the latter part of the Greater Kether includes the first part of the Greater ‘Hokma, so ‘Hokma in turn contains and initiates Binah, Binah Hesed, and so on down to the tenth Sephira, Malkuth.

We can observe, then, that the first complete subjective Tree of ten minor Sephiroth, while it has its roots in the Greater Kether, actually commences with the creation or emanation of the Greater ‘Hokma, and forms the Tree of Life in the world of Atziluth. It becomes complete at the point where the completed ‘Hesed stirs to life the energies of the about to become independent Greater Geburah. This observation is useful for those who may wish to study the “wisdom” literature of the Bible and Apocrypha, which is finding an increasing resurgence of interest among many people.

PATH SEVEN

The 7th Path is called the Hidden or Occult Intelligence נסתר. It pours out a brilliant splendour on all virtues which are beheld with the eyes of the spirit.

‘Hokma is wholly and entirely in Atziluth, and is thus the first complete manifestation of spirit.

Sepher Yetzirah: The East. Heh, Yod, Vav. The letter Aleph א governs in air, fused with the other two, producing the air in the universe, the temperate state in the year, and the chest in human beings - the male with אבא and the female with אמה.

The Minor Sephiroth: Daath in Atziluth. Aleph. Air. Pillar of Equilibrium.

Commentary: Knowledge of Heaven. The Non-Sephira Daath is said to be invisible. This mystery is made plain by the arrangement of the Ladder. Of the objective or Greater Sephiroth there are ten only: ten and not nine; ten and not eleven. Of the subjective or minor Sephiroth there are ten in each world, plus Daath. As these Minor Sephiroth represent the rungs of the Ladder in the ascent of the Tree by developing awareness it must be said of them that they are subjective, as their importance to understanding lies in the relationship they bear to ourselves. Properly speaking they are Sephiroth only as a means of aiding our understanding, but based upon the principle that the true or Greater Sephiroth have their own principles reflected in all levels of creation. In reality they are simply paths, parts of the Greater Sephiroth, the objective Tree. In the subjective sense of minor Sephiroth they are all invisible.

Daath means Knowledge - knowledge, not mere information; not simply a collection of data. Knowledge comes only from experience. Data can come from many sources. It is knowledge which “pours out a brilliant splendour on all intellectual virtues which are beheld with the eyes of the Spirit.” It is the seventh and final part of the Greater Kether.

So exquisite is the subtlety of Kabbalah, and so accurate in its reflections, that discerning students come to realise that the “invisibility” of Daath, and its mystery, is shadowed or reflected in the arrangement of the Minor Sephiroth within the four worlds, being a state of the development of awareness which as soon as it is reached disappears, and becomes transformed into something else. This Path is the first appearance of any kind of Daath, as the “invisible” or “hidden intelligence” of the highest world of Atziluth. It is also the fourth part and central nucleus of the Greater ‘Hokma, Wisdom, and we may justly say that at the heart of Wisdom lies Knowledge. It is this that “pours out a brilliant splendour,” etc. Its appearance also tells us about the nature of knowledge itself. There has to be an eye to see, with intellectual virtues etc. before the “hidden” knowledge may pour out its brilliant splendour. There has to be a knower to know. True knowledge is of the nature of realisation, to use a modern expression, or of revelation, to use one not so modern, but which in some respects is more accurate as a description of the

nature of knowledge. Knowledge is more than an awareness of things; true knowledge is being, is consciousness itself.

In Freemasonry, said to be represented by the 27th Degree, "Commander of the Temple"

PATH EIGHT

The 8th Path is called the Perfect Intelligence שלם. The preparation of principles emanates from it.

Sepher Yetzirah: The West. Heh, Vav, Yod. The letter Mem מ governs in water, fused with the other two, producing the earth in the universe, cold in the year, and the belly in human beings - the male with ממש and the female with שמש.

The Minor Sephiroth: Hesed in Atziluth. Mem. Water. Pillar of Mercy.

Commentary: Justice of Heaven. The sphere Magnificence is a term descriptive of the Greater 'Hokma, from whose centre is poured out the "brilliant splendour."

We may conceive of the all-potential of the principle of 'Hokma as described in Part one in the light of the analogy of electrical energy such as lurks behind a thunderstorm, unseen but powerful sparks of primal energy looking for a form through which to find expression. At 'Hesed in Atziluth a ground plan exists to be given the potential for action in the Geburah of Atziluth as the greater "lightning flash" proceeds about its business of emanating the Greater Binah from within the Greater 'Hokma, a process seen from the arrangement of the Ladder to be taking place here.

PATH NINE

The 9th Path is called the Purified Intelligence מטהר. It purifies the emanations, establishing their unity.

Sepher Yetzirah: The South. Vav, Yod, Heh. The letter Shin ש governs in fire, fused with the other two, producing the heavens in the universe, heat in the year, and the head in human beings.

The Minor Sephiroth: Geburah in Atziluth. Shin. Fire. Pillar of Severity.

Commentary: The Judgement of Heaven.

PATH TEN

The 10th Path is called the Resplendent Intelligence מתנוצצ. It is exalted above every head, and has its seat in Binah בינה. It enlightens the fire of all lights and emanates the power of the principle of forms.

Sepher Yetzirah: The North. Vav, Heh, Yod. The first day of Creation. Life and Death. The letter Beth ב governs in Wisdom, producing Saturn in the universe, the first day in the year, and the right eye in human beings. Seven double letters ה פ ר כ נ ד ב whose foundation is Life, Peace, Wisdom, Well-being, Beauty, Fruitfulness, and Dominion. They are called double letters because each can be pronounced either soft or hard.

The minor Sephiroth: Tiphareth in Atziluth. Kether in Briah. Yoga: The *Sahasrara* chakra, above the head. Binah is half in Atziluth, half in Briah. The dual nature of this Sephira will be known to some students of Kabbalah. Also, Binah heralds the first principle of creation, that of limitation, which cannot begin before Briah.

The Christian Church: The triform east window, symbolising the transmission of the Knowledge of Heaven from path Seven. The Lady Chapel, when this is situated behind the high altar, symbolising the centre of the Greater Binah, the "Great Mother" and "Queen of Heaven."

Commentary: Redemption of Heaven. The divine world of Atziluth finds its centre here, and in doing so it enables the world of Briah to begin, so Creation as we understand it commences. This is also the highest point available to humanity, and the attributes of Atziluth are only available to us through the mediation of Briah, except in unusual circumstances. (Such as represented by the story of Moses on Mount Sinai, or of the Baptism of Jesus by John the Baptist, though we should be careful about taking these accounts literally).

The attribution of the letter Beth applies to Kether in Briah, and is related to the mystery of Daath. It will be noted that this Path is the lowest point of the Greater 'Hokma, in which lies the mystery of knowledge on the scale of the Ladder. This knowledge is symbolised in the Church by the light which enters from the east window, set high above the level of the sanctuary altar. The attribution of the north by the Sepher Yetzirah shows an earlier understanding of the cardinal points, and many early burial sites and places of pre-Christian worship were so aligned. The east-west alignment of the cruciform church is of comparatively late origin. It is interesting to note that the first British church of Joseph of Arimathea at

Glastonbury was said to have been circular, as were those of the Templars of the twelfth century. At Path Ten Creation as we may experience it has begun. *In Freemasonry. said to be represented by the 24th Degree, "Prince of the Tabernacle"*



PATH ELEVEN

The 11th Path is called the Fiery Intelligence מְצוּחָצָח.

Sepher Yetzirah: The letter Gimel ג governs in Well-being, producing Jupiter in the universe, the second day in the year, and the left eye in human beings. The second day of creation.

The Minor Sephiroth: Netzach in Atziluth. 'Hokma in Briah.

The Christian Church: The consecrated wine. The candle to the right of the altar, if facing it.

The Tarot: The un-numbered card, "The Fool."

Commentary: In some arrangements, this Path connects the Sephiroth of a single Tree from Kether to 'Hokma. This is the only instance where the Ladder has such a direct correspondence. In either case, this Path is immediately adjacent to a form of Kether. The arrangement of the Ladder is the more precise. In a general sense, Kether is certainly the "cause of causes," but here the relationship is shown to be in the world of Briah, and the Kether of Briah is specified. To clarify this, some deeper understanding of Briah is necessary. The Hebrew word Briah means creation, or a thing created, and it is created things which are the cause of effects in the phenomenal world with which we are familiar. It follows quite naturally that the Kether of Briah is itself, in such a context, the "cause of causes." This however is not enough to explain the attribution, and we need to look more closely at the text of the Path. It is also the "veil placed before the order of the dispositions of the superior and inferior causes." This makes the matter clearer, for we can see that the superior causes will be those of the world of Atziluth, and the inferior causes those of the world of Briah, one step removed, and it is therefore the cause of the "inferior" or lower causes that is referred to, i.e., Kether in Briah. This Path also marks the station of Netzach in Atziluth, and veils the Tiphareth of Atziluth in the same way. When an understanding of the nature of Tiphareth in a fuller sense is appreciated, we find here one of the most exquisite and subtle accuracies of the Teaching. It is the firmness of heaven, the wisdom of paradise.

PATH TWELVE

The 12th Path is called the Intelligence of Transparency or Light בְּהִיר. *The source of magnificence, said to be the source of vision in those who see apparitions.*

Sepher Yetzirah: The letter Daleth ד governs in Fruitfulness, producing Mars in the universe, the third day in the year, and the right ear in human beings. Wisdom and folly. The third day of creation.

The Minor Sephiroth: Hod in Atziluth. Binah in Briah.

The Christian Church: The consecrated bread. The candle to the left of the altar, when facing it.

The Greater Tarot: Card one, the "Magician."

Commentary: The Glory of heaven. The understanding of paradise. Reference has been made to the association of "magnificence" with 'Hokma. Here it is applied in the subjective sense of the minor Sephiroth, for Binah is indeed the direct reflection of the preceding 'Hokma, but here on the lower scale of Briah. It is worth noting yet again that this concept of each succeeding Sephira being in a sense a reflection of its predecessor holds good throughout. Hod in Atziluth is the glory or splendour of Atziluth, and the association of glory or splendour with light is a natural one. There is a suggestion here that the author of the text is repeating instruction received, but is not familiar with this Path, saying, "It is said, etc." Far from being a criticism of the author of the "32 Paths" this tells us that here must indeed have been a true Kabbalist, saying in effect, "Here is Kabbalah as I have received it. I have not necessarily experienced everything that I tell you about, but this is the teaching as I understand it."



PATH THIRTEEN

The 13th Path is called the Inductive Intelligence of Unity מנהיג or השחרות. The substance of glory, it manifests truth to every spirit.



Sepher Yetzirah: The letter Kaph כ governs in Life, producing the Sun in the universe, the fourth day in the year, and the left ear in human beings. Wealth and poverty. The fourth day of creation.

'HESED is complete in both Atziluth and Briah. This illustrates its function as the first Sephira of recognisable form.

The Minor Sephiroth: Yesod in Atziluth. Daath in Briah.

The Christian Church: The place of the Cross upon the altar. The centre of the sanctuary. The altar itself. Consecration. The station of the priest in Communion.

The Tarot: Card two, the "High Priestess."

Yoga: The Ajna chakra, between the eyebrows, or "third eye."

Mantra: OM (AUM).

The placing of Hindu and Yoga mantras from this point downward on certain central paths shows the proper perspective for these sometimes valuable practices. In esoteric terms, the various chakras relate not to some mysterious exalted state, but to quite definite physical locations in the body, except they should properly be understood as applying not to the material

"shell" but to the etheric structure, as it is usually called, upon which this "shell" is built. The etheric structure belongs to the worlds of Briah and Yetzirah, of creation and formation, hence the chakras commence with their highest point in these two worlds, i.e., Kether in Briah.

Commentary: The Foundation of Heaven. The Knowledge of Paradise.

This is one of the most important of the 32 Paths, so far as the possibility of human development is concerned. One is tempted to play the Kabbalistic game of Gematria, and observe that the Hebrew Achad, unity, adds up, by the sum of its letters, to 31, which reduced numerologically, equals 4, the sum of the 1 and 3 of Path 13. Further, the temptation also exists to observe that 13 is a "mirror image" of 31, and therefore may symbolise perfectly the process of induction implicit in the text. For a spiritual person this is the most holy place of all, for it is from here that we receive the highest possible benediction in this world. Kabbalah, we are told, was first taught to humanity by the angels, and it is in Paradise that the angels are said to work. If we have the knowledge of Paradise, then it becomes possible for us to contact, and even converse with the angels. But as may be seen from the place of this Path upon the Ladder, and from the attributions given above, this is an exalted place to be, and an exalted state to achieve. It is "inductive of unity," that is to say that unity is called forth from above to this place, for those that successfully lift their awareness to this level, and it "manifests truth to every spirit." Note: to every spirit, not to every soul, nor every body. This Path is truly "esoteric," that is, for the few who can reach it. It is not however therefore reserved for some special "elect" - the error of the gnostics - but is freely available to all through the descent of the Holy Spirit. Indeed, this is the place of this descent, however we regard the process, and also the place of the offering up of the individual spirit for spiritual service, however we understand that service. In the body of a Christian cruciform cathedral or abbey church, it is the only part of the building symbolically in the world of Atziluth, the only place where contact with heavenly things may be found. It is the very foundation of heaven, in which we may find divinity within us. It has also been described as the knowledge of paradise, which can be a highly technical term. Knowledge is only possible by experience, and we may, when we know how, experience the state of paradise, if only temporarily, here. Here also we may receive directly the inspiration of Holy Spirit in full consciousness, an experience never to be forgotten, and which can change our whole life.

So much may be said regarding this Path, that the mind can be overwhelmed by the implications. The student is advised therefore to study the implications personally, to consider, to contemplate, to meditate, and to seek to understand the awe-ful mystery of the "Inductive Intelligence of Unity." As the work is done, so truth will indeed be manifest to our individual spirit, and we will hesitate to speak of it.

Like the sun whose symbol is placed here, the light of Spirit may shine within us. We will then need to learn how to "let our light shine" without "casting pearls before swine." This can only be done by learning at the same time to receive the truth which is manifest to the spirit and allowing the Spirit, not the person, to speak. *In Freemasonry, said to be represented by the 21st Degree.*

PATH FOURTEEN

The 14th Path is called the Luminous or Illuminating Intelligence **לס"ד**.
The institutor of mysteries, and foundation of holiness.

Sepher Yetzirah: The letter Peh **פ** governs in Dominion, producing Venus in the universe, the fifth day in the year, and the right nostril in human beings. Beauty and ugliness. The fifth day of creation.

The Minor Sephiroth: 'Hesed in Briah. The Christian Church: The chalice.

The Tarot: Card three, the "Empress."

Commentary: The attribution of the chalice shows a direct comparison with the remarks on 'Hesed made in part one. It is a form of the triangular-shaped pyramid "bottle" referred to there, and its 'Hesedic nature is shown here in the form of an instrument in the work of creation in the world of Briah. Note that this Path follows upon the receipt of the power of truth, of the Holy Spirit, and is called the foundation of holiness. Holiness is a human quality which cannot begin to be manifest until the influence of the spirit reaches downward and outward into humanity. Before this can happen, it must be contained according to the principles we have described, in which lies the significance of the wine poured into the chalice to be consecrated at Path 13 in the centre of the sanctuary, becoming, symbolically the very "blood" of Christ (Greek Christos = "Anointed (One)" which flows down the side pillar from Path 11 by this act of consecration. Both the Sepher Yetzirah and the Tarot attribute the planet Venus to this Path, and may be for some the first explanation of the planetary symbol for Venus upon tarot card three. Throughout this section, although the attributions of the Tarot are given, there is little or no commentary upon them. The cards represent a system in themselves, and such a commentary really requires a separate treatise, where they can be considered together. The justice of paradise.



PATH FIFTEEN

The 15th Path is called the Constituting Intelligence **מטמ"ד**. It constitutes creation in the darkness of the world. It is itself that darkness mentioned in Scripture (Job, 80:9) "The cloud and the envelope thereof."

Sepher Yetzirah: The letter Resh **ר** governs in Peace, producing Mercury in the universe, the sixth day in the year, and the left nostril in human beings. Fruitfulness and barrenness. The sixth day of creation.

The Minor Sephiroth: Geburah in Briah.

The Christian Church: The paten.

The Tarot: Card four, the "Emperor."

Commentary: The Judgement of Paradise. "Then the Eternal answered Job from the heart of the tempest, saying: Who is this obscuring my designs with empty-headed words? Brace yourself like a fighter; now it is my turn to ask questions and yours to inform me. Where were you when I laid the earth's foundation? Tell me, since you are so well-informed? Who decided the dimensions of it, do you know? Or who stretched the measuring-line across it? Who supports its pillars at their bases? Who laid its cornerstone when all the stars of the morning were singing with joy, and the Children of God in chorus were chanting praise? Who pent up the sea behind closed doors when it leapt tumultuous out of the womb, when I wrapped it in a cloud of mist and made black clouds its swaddling bands; when I marked the bounds it was not to cross and made it fast with a bolted gate? Come thus far, I said, and no further: here your proud waves shall break. Have you ever in your life given orders to the morning, or sent the dawn to its post, telling it to grasp the earth by its edges and shake the wicked out of it, when it changes the earth to sealing clay and dyes it as a person dyes clothes; stealing the light from the wicked and breaking the arm raised to strike? Have you journeyed all the way to the sources of the sea, or walked where the Abyss is deepest? Have you been shown the gates of death or met the janitors of shadowland? Have you any inkling of the extent of the earth? Tell me all about it if you have? Which is the way to the home of the light, and where does darkness live?"

(This is a modern adaptation of Job 38, verses 1ff).



PATH SIXTEEN

The 16th Path is called the *Eternal Intelligence* נצח, the *delight of glory, the heart of paradise prepared for the just.*

Sepher Yetzirah: The letter Tau ט governs in Beauty, producing the Moon in the universe, the seventh day in the year, and the mouth in human beings. The seventh day of Creation, when God rested.

The Vissudhi chakra, in the region of the throat.

The Tarot: Card five, The Hierophant. (*See below re the priesthood.*)

GEBURAH is centred in, and is the central sephira of Briah. At the same time, it is half in Atziluth and half in Yetzirah. It therefore illustrates the energy or impetus which brings the spiritual force of Atziluth through form (Briah) to formation (Yetzirah).

Commentary: The Dominion of Heaven. The Beauty of paradise. The Crown of purgatory. The Dominion (Kingdom) of Heaven is Malkuth in Atziluth - triumphant and eternal. In the ascent of the Ladder it is foreshadowed by Kether in Yetzirah -delight of glory - and by Tiphareth in Briah - paradise of pleasure, indicating the capacity of developing awareness to respond in varying ways to the powerful attraction of Spirit. The station of the priesthood in the Christian Church lies here, at the centre of Geburah, the top of three steps leading into the sanctuary. To this day it is common for the officiating priest to come down to this point to make the public announcements outward toward the congregation and the body of the church. In ideal terms the congregation is the body of the Church, but this is often lost sight of, particularly by congregations, and, perhaps, by not a few priests.

In Freemasonry, said to be represented by the 18th, or “Rose Cross” Degree.



PATH SEVENTEEN

The 17th Path is called the *Sensible or Disposing Intelligence* הדרגם, *disposing the devout to perseverance and preparing them to receive the Holy Spirit.*

Sepher Yetzirah: The letter Heh ה governs in Sight, Aries in the universe *Nisan* in the year, and the right hand in human beings. Twelve simple letters ק צ ע נ ס ל י ט ז ה ו ז ה ו ז ה, whose foundation is sight, hearing, smell, speech, taste, coition, work, movement, anger, laughter, thought, and sleep.

The Minor Sephiroth: Netzach in Briah. ‘Hokma in Yetzirah.

The Christian Church: The Book of the Epistles.

The Tarot: Card six, The Lovers.

Commentary: Victory in Paradise. Wisdom in Purgatory. In the downward development of the Ladder the world of Atziluth has been left behind, and we are deep in the actual processes of creation to the extent that the direct appreciation of the Spirit is no longer possible, and is mediated via the previous Path (and therefrom some form of priesthood). To the ascending awareness this Path prepares it to receive the Holy Spirit, by mediation, upon whatever level has been reached. In the highest sense, it is disposing and preparing the way for the incarnate being to attain the level of Tiphareth in Briah, from where it may first experience the World of Heaven as a preparation for the Spiritual Realm. In the Christian Church this preparation was probably performed in early times by a Deacon’s interpretation of the teachings contained in the “Book of the Epistles.” This now no longer exists as a separate book, although most likely it once did, and it is still symbolically given to a Subdeacon at ordination.



PATH EIGHTEEN

The 18th Path is called the Emanative Intelligence or House of Influence בִּיהַשְׁפַּע.

Sepher Yetzirah: The letter Vav ו governs in Hearing, Taurus in the universe, *Iyar* in the year, and the left hand in human beings.

The Minor Sephiroth: Hod in Briah. Binah in Yetzirah.

The Christian Church: The Book of the Gospels. The Book of the Law (Pentateuch).

The Tarot: Card seven, the “Chariot.”

Commentary: Here we find Kabbalah teaching about itself. From this level of Understanding in the world of Formation the Teaching has been incorporated in the Holy Scriptures of the Law, and by extension, the Christian Gospels. The book of the Gospels is given to Christian priests at ordination. According to Kabbalah, “concealed meanings repose in the shadow thereof.” No Kabbalist who has studied the scriptures of either the old or New Testaments can doubt this. It is implied frequently in the sayings attributed to Jesus such as “Who has ears to hear,” and, “Who has eyes to see,” etc. There is also a fascinating passage in Mark 13:14, “Let the reader understand,” referring to the Old Testament book of Daniel.



PATH NINETEEN

TIPHARETH is complete in both Briah and Yetzirah. It is the receptacle at the lower level which contains the Spirit brought down from the higher levels. Path 19 lies at its centre.

The 19th Path is called the Intelligence of the Secret of Spiritual Activities סוֹ גַּדְפַע וְלוֹמַע. *The fullness which it receives derives from the highest benediction and the Supreme Glory.*

Sepher Yetzirah: The letter Zain ז governs in Smell, Gemini in the universe, *Sivan* in the year, and the right foot in human beings.

The Minor Sephiroth: Yesod in Briah. Daath in Yetzirah.

The Christian Church: The station of the Sub-Deacon.

The Tarot: Card Eight, “Justice.”

Yoga: The Anahata chakra, in the region of the heart. Mantra: YAM.

Commentary: As Daath in Yetzirah, it is secret; i.e., the experience of this Path, while conferring knowledge of a Yetziratic kind, veils the truth implicit in that knowledge, better understood in Kabbalist fashion “by reception” at the “receptacle of the emanations” of Yesod in Briah, where the “Spiritual Activities” may be known as expressions of the Supreme Glory. (Path Two). The station of Sub-Deacon is of interest to those who know the minor orders of the Christian Church. The Ladder shows them in the usual ascending order. They fit exactly as they should.

Not only is Tiphareth complete in both Briah and Yetzirah, but it is the only Sephira simultaneously in contact with all four worlds. At its apex or “Daath” lies Path 16, the “Triumphant or Eternal Intelligence” - Malkuth in Atziluth, the heavenly Realm, the “paradise of pleasure prepared for the just.” This has also been described as a “second gate” equivalent to the second “shock” point in the Ouspensky teaching, which to quote one source gives rise to spontaneous prayer of the heart.

In the sequence of the Ladder Path 16 is also Tiphareth in Briah, which illustrates this.

At the base, or foundation, the “Yesod” point of Tiphareth, lies Path 22, the “Faithful Intelligence.” Of this Path it is said that “Spiritual virtues are deposited therein, until they pass to those who dwell under the shadow thereof.” The two texts quoted speak for themselves in describing the nature and function of this Sephira. Path 22 has been described as the “first gate” or “shock” point which arises because of attempts to awaken. It is also Kether in Assiah, so it can be seen that the Greater Tiphareth serves to bring through the final expression of divinity, the “delight of glory” (Path 16) the Malkuth of Atziluth, the Realm of the Spiritual world, into our own material Realm of Assiah. It transmits this influence by its existence as a bridge in Briah and Yetzirah from the lowest part of Spirit to the highest part of matter, Kether in Assiah - the divine spark in the material world. Thus is divinity brought to humanity, and is deposited within each member of the human race, and within every manifestation of creation.



In Freemasonry, said to be represented by the 15th Degree, “Knight of the Sword” - note that the Hebrew letter zain ז which means “sword” is also placed here.

PATH TWENTY

The 20th Path is called the Intelligence of Will הרצוף. It prepares all created beings, each individually, for the demonstration of the primordial glory.

Sepher Yetzirah: The letter Chet ח governs in Speech, Cancer in the universe, Tamuz in the year, and the left foot in human beings.

The Minor Sephiroth: ‘Hesed in Yetzirah.

The Christian Church: The lighted candle of the Acolyte.

The Tarot: Card nine, the “Hermit.”

Commentary: The “primordial glory” is Path One, called the “first splendour” and symbolised by “the light which imparts understanding of the beginning.” In ordination of a Christian Acolyte, this light is symbolised by the lighted candle which the candidate carries to the altar, and represents the will to serve. At the same time, it may be regarded as representative of that particle of the primordial light which the candidate is, and which constitutes the personal divinity, the presence of the spiritual essence. This throws some light upon the nature of human will. Ordinarily, we tend to equate will with desire, supposing that if we desire a particular thing, that our will is operating to obtain it. We should know this is not invariably the case, and we often realise with hindsight that our true will made sure that we did not, in a given instance, obtain the desire, which could have been harmful to us.

Ordinarily, and necessarily, will is not obviously active in us, and it is part of our work to learn how, when necessary, to contact our own will. When this happens, we begin to realise that we are much more than we supposed we were, and at the same time, much less. We have caught a glimpse of divinity in us, and we may become, by so doing, if not at the first instance, “anointed” by the experience. The Greek word Christos rendered as “Christ” in the New Testament, means “anointed [one]” as does Messiah in Hebrew, and such an experience may herald the appearance of what has been called “Christ in you.” Such an appearance is a necessary preparation for the demonstration to any of us of the existence of the primordial glory.



PATH TWENTY-ONE

The 21st Path is called the Intelligence of Desire החפירה המנוקשת, or the Rewarding Intelligence. It receives the divine influence, and so influences all living things.

Sepher Yetzirah: The letter Teth ט governs in Eating, Leo in the universe, Av in the year, and the right kidney in human beings.

The Minor Sephiroth: Geburah in Yetzirah.

The Christian Church: The candle-holder of the Acolyte.

The Tarot: Card ten, the “Wheel.”

Commentary: One of the esoteric orders derived from the Hermetic Order of the Golden Dawn attributed the right arm to Geburah, and the “candle-holder” of an Acolyte is held in the right hand. At ordination however, the left hand is brought to join the right, presenting the lighted candle to the bishop, symbolising the subordination of the human to the divine will, and in Kabbalist symbolism the balancing of both pillars of the Tree of Life.





PATH TWENTY-TWO

NETZACH is centred in, and is the central Sefhira of Yetzirah. At the same time, it is half in Briah and half in Assiah. As Geburah transmits spiritual impetus through form into formation, so Netzach transmits form, through formation, toward material manifestation. Path 22 is its central point.

The 22nd Path is called the Faithful Intelligence נאצח. Spiritual virtues are deposited and grow there, passing their benefits to those below.

Sepher Yetzirah: The letter Yod ך governs in Coition, Virgo in the universe, Elul in the year, and the left kidney in human beings.

The Minor Sephiroth: Malkuth in Briah. Tiphareth in Yetzirah. Kether in Assiah.

The Christian Church: The station of the Acolyte.

The Tarot: Card eleven, "Strength."

Yoga: The Manipura chakra, in the region of the Solar Plexus.

Mantra: RAM.

Commentary: Realm of Paradise; Heart of Purgatory; Crown of Hades.

Path 22 is the centre of the Greater Netzach. This is the point of creation where we, as mortal beings, are normally aware of it, if we are aware of it at all. The world of appearances with which we are familiar at its lower levels has its roots, in other words, in the Sefhira Netzach. This might account, according to the view of Netzach held by some, for the repetitive nature of this lower world. Such a recognition of the constantly recurring cycles of birth, maturity, decay, and death, is often the starting point of those who look for deeper explanations of things. Eventually, such enquiry brings the enquirer to search within, at which point the association of this Path with a Christian Acolyte is appropriate, for it is here that the Acolyte may first receive "light from above" after the manner of the text. When the spiritual virtues deposited within have duly augmented, the Acolyte will understand the significance of this position at the Malkuth of Briah, and be ready to commence further training. At this stage, we are, as one author put it, "Hewers of wood and drawers of water" - that is to say, willing seekers glad to serve in the temple of the Spirit.

In Freemasonry, the 12th Degree is said to be represented here.

PATH TWENTY-THREE

The 23rd Path is called the Stable Intelligence נצח. It is the source of consistency in all the numerations.

Sepher Yetzirah: The letter Lamed ל governs in Work, Libra in the universe, Tishri in the year, and the liver in human beings.

The Minor Sephiroth: Netzach in Yetzirah. 'Hokma in Assiah.

The Christian: Church: The book of exorcisms.

The Tarot: Card twelve, the "Hanged Man."

Commentary: Netzach, here seen in the world of Yetzirah, is called, apart from "Victory" - the translation of "Netzach" - by the title of Firmness, which echoes the idea of stability suggested by the text. As it is also "Hokma in Assiah, we might say that the wisdom of the material world is characterised by a certain inner firmness, something which may be observed as a factor in the character of many successful people. In the context of the practice of exorcism, the use of such practices must clearly be undertaken by those who can employ material wisdom based upon stability within themselves. No one should be trained as an exorcist who does not accept the discipline that goes with such training.





PATH TWENTY-FOUR

The 24th Path is called the Imaginative Intelligence נ"טו"נ. It is the ground of similarity in the likeness of beings who are created to its agreement, after its aspects.

Sepher Yetzirah: The letter Nun נ governs in Movement (walking), Scorpio in the universe, *Marchesvan* in the year, and the spleen in human beings.

The Minor Sephiroth: Hod in Yetzirah. Binah in Assiah.

The Christian Church: The sword of exorcism.

The Tarot: Card thirteen, "Death."

Commentary: "The Imaginative Intelligence, which is the ground of similarity in the likeness of beings who are created according to its agreement" is the imaginative Hod faculty of Yetzirah at the same time as it is the understanding of the material. There is a double association with the concept of death here in the tarot card and the sign Scorpio, which in astrology is associated with the eighth house, the house of death.

The understanding and intelligence of Kabbalah makes it clear that death is not regarded as a finality, but as a transitional process, for by associating it with Binah in Assiah, where we may assign the process of physical death, it also relates it to Hod in Yetzirah, into which the physical may be transformed in another form of existence. Note that the text of this Path is concerned with created beings - such as ourselves.

Note also that Kabbalah does not place death where we might expect it, i.e., at the end of things, but at an intermediate point. The Tarot takes the same view, for it is only the thirteenth card of twenty-two.

In this commentary on the Ladder we are referring to a downward progression through the thirty-two Paths of Wisdom, so that it may not be appropriate to go deeply into this question here, for the process which describes the transformation described as death is in the nature of an upward progression through the worlds, and can also be looked at on the scale of the twenty-one stages of Part Two, or alternatively by regarding the symbolism of the tarot in its own terms from the first to the last card, where the subsequent stages may be examined and pondered upon. They should also be wondered upon. Much experience in the work of Kabbalah comes from of a simple sense of wonder, much as we had as children. Experience of what this means helps to explain the teaching, "become like little children."

PATH TWENTY-FIVE

HOD is complete in both Yetzirah and Assiah. It orders the formations of Yetzirah into recognisable Assiatic forms - in principle. Almost anyone can climb this far up the Ladder with little difficulty. Path 25 is at the centre of Hod.

The 25th Path is called the Intelligence of Temptation or Trial נ"טו"נ because it is the first temptation by which God tests the devout.

Sepher Yetzirah: The letter Samech ס governs in Anger, Sagittarius in the universe, *Kislev* in the year, and the gall-bladder in human beings.

The Minor Sephiroth: Yesod in Yetzirah. Daath in Assiah.

The Christian Church: The station of the Exorcist.

The Tarot: Card fourteen, "Temperance" or "The Angel."

Yoga: *The Svadhisthana chakra, in the genital region.* Mantra: VAM.

Commentary: This Path is the centre of the Greater Hod, which is also the first of the Greater Sephiroth entirely in the world of Assiah, and is, for the student, the most important of the Greater Sephiroth. A complete book could be written about this Sephira alone, and while we are in the flesh, we are concerned with its activity for the entire period of our earthly lives. This adds an almost ominous significance to the text of the Path. It explains the importance of the function of exorcism as properly understood, which has little to do with the expulsion of demons, and more to do with healing.

Sagittarius is the sign of the house which rules philosophy and religion, and Kabbalah is both of these. The Tarot card shows a figure with a foot in each of two worlds, having knowledge of the material world, and a foundation in the world of formation, from which a path is shown leading yet further.

The Manipura Chakra (Path 22, the uppermost part of Hod) is in the region of the solar plexus, through which all human experience is co-ordinated and distributed in life. The Greater Sephira Hod, as a whole,



comprises half the world of Assiah, from its Kether to its Tiphareth. When we know this half of our Assiatic Tree we shall have made real progress.

In Freemasonry, the 9th Degree is said to be represented here.



PATH TWENTY-SIX

The 26th Path is called the Renewing Intelligence מחדש, for thereby God renews all that is capable of renovation in the creation of the world.

Sepher Yetzirah: The letter Ayin א governs in Laughter, Capricorn in the universe, *Teveh* in the year, and the large intestine in human beings.

- The Minor Sephiroth: ‘Hesed in Assiah.
- The Christian Church: The Book of Epistles.
- The Tarot: Card fifteen, the “Devil.”

Commentary: “Thereby God reneweth all which is capable of renovation in the creation of the world.”

One day the Children of God came to attend upon the Eternal, and among them was Satan. So the Eternal said to Satan: Where have you been? “Round the earth,” he answered, “roaming about.” So the Eternal asked: Did you notice my servant Job? There is no one like him on the earth; a sound and honest man who fears God and shuns evil. “Yes,” said Satan, “but Job is not God-fearing for nothing, is he? Have you not put a wall round him and his house and all his domain? You have blessed all he undertakes, and his flocks through the countryside. But stretch out your hand and lay a finger on his possessions; I warrant you he will curse you to your face.” The Eternal said to Satan: “Very well; all he has is in your power, but keep your hands off his person.”

“Then Jesus was led by the Spirit out into the wilderness to be tempted by the Devil . . . The Devil showed him all the dominions of the world and their splendour. ‘I will give you all of these,’ he said, ‘if you worship me.’ Jesus replied: Be off Satan!”

These instances show a far different picture of the satanic role than that depicted in the popular imagination, or, for that matter, in many theological or church circles. It is quite clear that in Old and New Testament times, the role of “Satan” (a word meaning “adversary”) was regarded as a legitimate and divinely approved function.

PATH TWENTY-SEVEN

The 27th Path is called the Natural Intelligence מיטבע, whereby the nature of everything found in the orb of the sun is completed and perfected.

Sepher Yetzirah: The letter Tzaddi צ governs in Thought (Meditation), Aquarius in the universe, *Shevat* in the year, and the stomach in human beings.

- The Minor Sephiroth: Geburah in Assiah.
- The Christian Church: The Book of the Gospels.
- The Tarot: Card Sixteen, the “Tower.”

Commentary: Crowley was correctly informed. Tzaddi is not the Star . . . This is about perfection-completion requiring seeming disintegration, and apparent destruction (compare Tarot Tower). It is the other half of Path 26 (Renewing) balance.

27..... 26



PATH TWENTY-EIGHT



Yesod is half in Yetzirah, half in Assiah. It is the means of translation of the ordered formations of Yetzirah into material shape. Path 28 is at the centre of Yesod.

The 28th Path is called the Active Intelligence צורנתש, for thence is created the spirit of every (living) creature of the supreme orb, and the activity, the motion to which they are subject.

Sepher Yetzirah: The letter Qoph ק governs in Sleep, Pisces in the universe, Adar in the year, and the small intestine in human beings.

The Minor Sephiroth: Malkuth in Yetzirah. Tiphareth in Assiah.

The Christian Church: The station of the Reader.

The Tarot: Card seventeen, the “Star.”

Yoga: *The Muladhara chakra at the base of the spine.* Mantra: LAM.

Commentary: The letters of the Hebrew alphabet end at Malkuth in Yetzirah, the bottom of the world of formation, for in terms of the letters formation is completed, and the heart or Tiphareth of Assiah is established. The remaining Paths form the cross of matter from which humanity (*Heb:* Adam) is

to be redeemed via Tiphareth. The Muladhara Chakra is thought to be particularly active during physical sleep.

“The spirit of every creature,” i.e., not the essential spirit of being itself, but of the creature, in this case the animal body, which has a limited identity of its own. This is seen mostly in the behaviour of survival mechanisms such as eating, sleeping, procreating etc.

From 28 to 32 we find the paths which belong to the lower half of the lowest world of Hades - which means “underworld,” but not “hell.” It is so called because it falls under the three worlds above. *In Freemasonry, it is said to be represented by the 6th Degree.*

PATH TWENTY-NINE

The 29th Path is called the Corporeal Intelligence מוגשם. It informs every (physical) body, and it is the growth thereof.

The Minor Sephiroth: Netzach in Assiah.

The Christian Church: The Bell.

The Tarot: Card eighteen, the “Moon.”

Commentary: The reader is referred to the section on Netzach in Part One. Note: There is no longer any Sepher Yetzirah entry—we have left Yetzirah.



PATH THIRTY

The 30th Path is called the Collective Intelligence כללי, for thence astrologers by the judgement of the heavenly signs derive their speculations and the perfection of their science according to the motion of the stars.

The Minor Sephiroth: Hod in Assiah.

The Christian Church: The key to the door.

The Tarot: Card nineteen, the “Sun.”

Commentary: The Collective Intelligence, or according to Blavatsky, Gathering Understanding. Again compare the nature of the Sephira Hod as described in Part One.



PATH THIRTY-ONE

MALKUTH is completely and wholly in Assiah. The form is complete. Path 31 is at the centre of Malkuth.

The 31st Path is called the Perpetual Intelligence תמידי. It rules the movement of the sun and moon according to their constitution and causes each to gravitate in its respective orb.

The Minor Sephiroth: Yesod in Assiah.

The Christian Church: The station of the Doorkeeper.

The Tarot: Card twenty, "Judgement."

Commentary: The centre of the Greater Malkuth, the larger world of the solar system as a whole, or even of the galaxy.

In Freemasonry, it is said to be represented by the 3rd Degree, or "Master Mason" - a fitting attribution for the approach into Yesod, Foundation, of which this Path forms the lowest point. (See the diagram of the Ladder).



PATH THIRTY-TWO

The 32nd Path is called the Assisting Intelligence נעבר. It directs the operation of the seven planets, with their divisions, and concurs therein.

The Minor Sephiroth: Malkuth in Assiah.

The Christian Church: The Clerk in Orders.

The Tarot: Card twenty-one, the "World."

Commentary: "The Serving Understanding. A disposer of all those that are serving in the work of the seven planets, according to their hosts." - Blavatsky, "The Secret Doctrine."

Malkuth in Assiah has also been given the title of "The Gate" and in the Abbey arrangement is clearly seen as the "Gate" or Great West Door by which postulants are admitted.

In Freemasonry, the 2nd Degree or "Fellow Craft" members are said to be admitted here. Although apprentices may be also admitted here (1st Degree) for initiation, it is sometimes said that their instruction would, in ancient times, have been given in the lobby of the building, which is technically outside the Temple proper. This lobby can be clearly seen in many of the Cathedral and Abbey Churches in Britain.

MALKUTH

The Greater Malkuth consists of Paths 28 to 32 of the 32 Paths. The 28th Path is the Active Intelligence, "Whence is created the spirit of every creature." The 29th Path is the Corporeal Intelligence, which "informs every body" and "is the growth thereof." The remaining three Paths are all concerned with the actual mechanics of our material domain, referring as they do to the movement of the Sun, Moon and Planets within the zodiac. The whole presents a graphic image of our world in space, with its many forms of life, all of which have the essential Spirit within a corporeal or bodily framework. The entire system of Sun, Moon and Planets may be similarly regarded, as each is also a body of a different kind, with its own spiritual essence.

Regarded from the point of view of humanity on this earth - a lowering only of scale - the symbolism of the Tarot trumps can be seen to present a different but significant meaning. At the bottom of the cross of Malkuth is "The World" showing a figure clearly in a state of joy and command, the ideal of each of us in this earthly existence. We are all subject to the influences of Sun, Moon and Stars, and the astrology of Path 30, and we find the cards depicting this in the first three positions of the circle. In the centre is "Judgement" and the angel calling forth the dead from their graves. This card can have a great wealth of meaning, as is obvious, but at a purely superficial level of symbolism we can see how cards 20 and 21, "Judgement" and "The World" indicate that all forms of material existence ultimately die. That is to say, that the form dies; but what of the spirit? This, as has been shown, is conferred by the 28th Path, which is also the centre of the sphere of the Greater Yesod, whose name is God of Life, or the Living God, which is that Spirit. The name of God in Malkuth however is simply Ruler of Earth. So we may say that body, of itself, can have no life unless Spirit indwells it and "informs" it through the Corporeal Intelligence. The death of the body merely heralds the liberation of the Spirit.

This is what Kabbalah is about, because it seeks to help us prepare for and understand the nature and fact of this liberation, and perhaps to smooth our paths a little as we travel toward it.

APPENDIX ONE

A SUMMARY OF THE 32 PATHS AS ILLUSTRATED BY THE THREE VEILS AND THE MINOR SEPHIROTH TOGETHER WITH A SHORT TITLE DESCRIBING THE INTELLIGENCE OF EACH PATH AND A WORKING ATTRIBUTION OF THE TAROT TRUMPS.

1. Ain. Admirable.
2. Ain Suph. Illuminating.
3. Ain Suph Aur. Sanctifying.
4. Kether in Atziluth. Arresting or Receiving.
5. 'Hokma in Atziluth. Radical.
6. Binah in Atziluth. Mediating.
7. Daath in Atziluth. Hidden.
8. 'Hesed in Atziluth. Perfect.
9. Geburah in Atziluth. Purified.
10. Tiphareth in Atziluth. Kether in Briah. Resplendent.
11. Netzach in Atziluth. Kether in Briah. Fiery. (The divine) Fool.
12. Hod in Atziluth. Binah in Briah. Intelligence of Light. Magician. I
13. Yesod in Atziluth. Daath in Briah. Inductive. High Priestess. II
14. 'Hesed in Briah. Illuminating. Empress. III
15. Geburah in Briah. Constituting. Emperor. IV
16. Malkuth in Atziluth. Tiphareth in Briah. Kether in Yetzirah. Eternal. Hierophant. V
17. Netzach in Briah. 'Hokma in Yetzirah. Disposing. Lovers. VI
18. Hod in Briah. Binah in Yetzirah. Influence. Chariot. VII
19. Yesod in Briah. Daath in Yetzirah. Secret. Justice. VIII
20. 'Hesed in Yetzirah. Will. Hermit. IX
21. Geburah in Yetzirah. Rewarding. Wheel. X
22. Malkuth in Briah. Tiphareth in Yetzirah. Kether in Assiah. Faithful. Strength. XI
23. Netzach in Yetzirah. 'Hokma in Assiah. Stable. Hanged Man. XII
24. Hod in Yetzirah. Binah in Assiah. Imaginative. Death. XIII
25. Yesod in Yetzirah. Daath in Assiah. Temptation. Angel (Temperance). XIV
26. 'Hesed in Assiah. Renewing. Devil. XV
27. Geburah in Assiah. Natural. Tower. XVI
28. Malkuth in Yetzirah. Tiphareth in Assiah. Active. Star. XVII
29. Netzach in Assiah. Corporeal. Moon. XVIII
30. Hod in Assiah. Collective. Sun. XIX
31. Yesod in Assiah. Perpetual. Judgement. XX
32. Malkuth in Assiah. Assisting. World. XXI

The composite tree in four worlds

In this arrangement the four worlds rise as follows:

ASSIAH: Malkuth - Yesod - Hod - Netzach -

Tiphareth - Geburah - 'Hesed

YETZIRAH: Yesod - Hod - Netzach - Tiphareth - Geburah - 'Hesed.

The Sephiroth in Yetzirah are those of Assiah without Malkuth. This can be seen when we consider the etheric body of a person. This likewise is commenced in 'Hesed, and completed in Yesod. This foundation for the physical body necessarily accompanies the physical body in Assiah, so that the world of Assiah contains it, and, by analogy, all the Yetziratic sephiroth, plus Malkuth.

BRIAH: Yesod - Hod - Netzach - Tiphareth - Geburah - 'Hesed - Daath - Binah - 'Hokma.

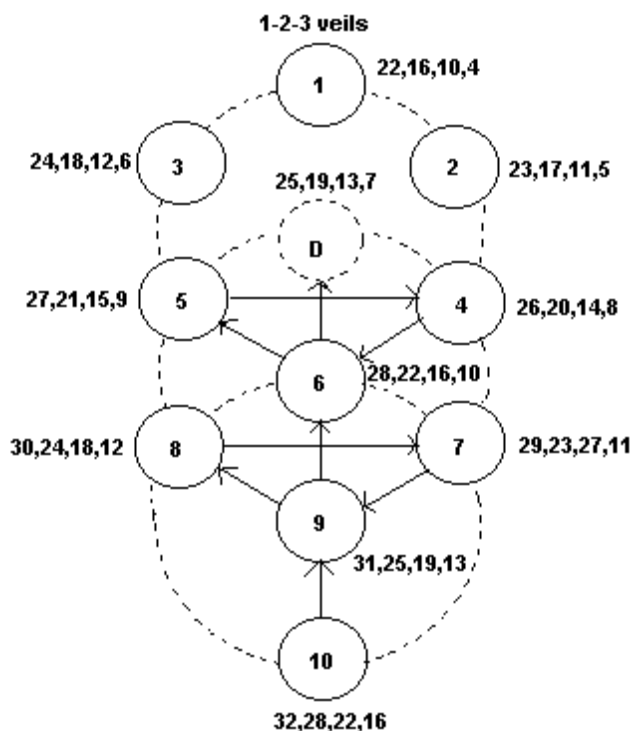

ATZILUTH: Kether - Ain Suph Aur - Ain Suph - Ain.

(The 3 veils are added as, strictly speaking, they are to Kether as the etheric body is to the physical, although they are nonetheless separate Paths above Kether in Atziluth on the scale of the Ladder).

APPENDIX 2

THE COMPOSITE TREE IN FOUR WORLDS

When we condense the glyph of the Ladder in such a manner as to show one Tree in four worlds simultaneously, we find ourselves with a representation identical with the traditional forms of the Tree generally published, revealing Daath in its usual position astride the Abyss. The diagram shows this arrangement, with the numbers of the 32 Paths appropriate to each minor Sephira in each world. For example, alongside Malkuth are the numbers of Paths 32, 28, 22 and 16. In other words, Malkuth in Assiah is shown by Path 32, in Yetzirah by Path 28, in Briah by Path 22, and in Atziluth by Path 16, and so with the other Sephiroth, including Daath, which acts in practice only through another Sephira, as is implicit in the glyph of the Ladder. Likewise we shall see an affinity between various Sephiroth. For example, Malkuth, Tiphareth and Kether have Paths 22 and 16 in common, Yesod and Daath have Paths 25, 19, and 13 in common, whereas 'Hesed and Geburah have no connection with any other Sephira, which matter is also referred to elsewhere. There is considerable food for thought in this arrangement, which can obviously give the keys to a number of mysteries of the familiar traditional True of life.

THE THREE VEILS

Kether, it is said, is in Malkuth, but after another manner. It may also be said that

Malkuth is an analogue of Kether. In a similar way, the three veils of negative existence have their analogues in the body of the Tree. Highest on the Tree is the veil of the Abyss. This, as it were, bisects the “invisible Sefhira” Daath through the centre of the Abyss. Daath being a function of Tiphareth consciousness, this veil cannot even be approached until the latter is established in the aspirant to higher things. At this stage, the veil of the Abyss serves to shield the full light of the Supernals. It is said to bisect Daath because Daath is formed partly by the rising Tiphareth consciousness - below the veil - and partly by the Knowledge called forth thereby from the Supernals - above the veil. The veil of the Abyss is analogous to the highest of the three veils of negative existence, Ain. Centrally on the Tree is the well-known and much referred to veil of *Paroketh*, which veils the full light of Tiphareth or Self-consciousness until such time as the Yesod-based personality is sufficiently prepared, when it may form a firm foundation (Yesod) for the power of Self without becoming disoriented, at which stage the veil of Tiphareth, analogous to Ain Suph, is breached, and the aspirant begins consciously to BE. Lowest on the Tree, analogous to Ain Suph Aur, is the rarely-mentioned veil of Yesod, which shields the higher worlds of Yetzirah, Briah and Atziluth from the sleeping consciousness in Assiah. Below this veil, the “soul” is said to be asleep (Jesus, less kindly perhaps, said “dead”) and entirely personality-based, mechanistic, governed by action/reaction. Individuals wondering about their place in the scheme of things create impulses towards the upper part of Yesod, the dualistic “moon” Sefhira, which may in time result in the commencement of the Way, where the individual becomes an aspirant to the knowledge of higher things, and this veil is thereby breached.

THE GREATER TAROT

The tarot trumps are here transposed from the diagram of the Ladder, and ensuing attributions are given in ascending order of the Sephiroth, as this is the direction in which we should be going. [The significance of this can only be experienced.]

MALKUTH is simply the “World” (21) in Assiah.

YESOD in Assiah is “Judgement” (20) calling forth the dead (as Jesus put it) into life, or the sleeping (as Ouspensky put it) into awakening. Yesod in Yetzirah is “The Angel” (14) holding the balance of the forces, maintaining the flow of the waters of life. Yesod in Briah is “Justice” denoting “karma”.

HOD in Assiah is “The Sun” (19), the intellectual, masculine principle. Hod in Yetzirah is “Death” (13). This principle (Hod) is at its worst at Yetziratic levels and most easily subject to deception, or to be overcome by illusion. Hod in Briah is “The Chariot” (7). Intellect is here seen in command of the rich and varied Yetziratic imagery.

NETZACH in Assiah is “The Moon” (18), the feminine feeling principle. Netzach in Yetzirah is “The Hanged Man” where illusion can take over both intellect and feeling, so that nothing appears as it really is. Netzach in Briah is “The Lovers” (6) where once more the aspirant may distinguish between the real and the unreal.

TIPHARETH in Assiah is “The Star” (17) to which the aspirant aspires, and seeks to become. Tiphareth in Yetzirah is “Strength” (11) which keeps its integrity even in the face of the most powerful forces (the lion). Tiphareth in Briah is “The Hierophant” (5) representing the knowledge and conversation of the Holy Guardian Angel which becomes possible here.

GEBURAH in Assiah is “The Tower” (16) The aspirant sees this force as destructive. The penetration of unconscious insight destroys illusions. Geburah in Yetzirah is “The Wheel” (10). Desires are the motivating force of this world. The aspirant turns in all directions seeking insight. Geburah in Briah is “The Emperor” (4). Here the forces of desire may be controlled. Insight is consciously employed.

’HESED in Assiah is “The Devil” (15). The roots of material existence seem to aspirants to hold them to this world of which Satan (adversary) is said to be in charge. ’Hesed in Yetzirah is “The Hermit” (9). The aspirant on the journey has discovered the origin of the light which is necessary for the path. ’Hesed in Briah is “The Empress” (3) mother nature, origin of all forms in material existence.

DAATH is in Briah only, being a function of consciousness, and not a Sephira.

“The High Priestess” (2) is Knowledge, and has the law. Only in Briah is true knowledge possible. She sits between the pillars of the temple, veiling the godhead of Kether, which is forever invisible.

BINAH is in Briah only, “The Magician:” (1) creating form for all.

’HOKMA is in Briah only, “The Fool”, unnumbered, representing the universal nature of the divine consciousness. (Compare with ’Hokma in Part One).

KETHER is not and cannot be represented, being above all, a crown.

The three cards “Fool” - “Magician” - “Priestess” are in a manner representative of the Supernals above the Abyss. To conform to the traditional Tree pattern we must remove the hidden Daath, in which case “The Fool” falls on Kether, “The Magician” on ’Hokma and “The Priestess” on Binah, which is in accord with the teaching. Also on a single Tree in four worlds Daath should not be represented, being a state of consciousness, not a principle of Law, as are the other Sephiroth.

THE SEVEN HEAVENS

A correlation on the basis of *The Testament of Levi* compared with the Paths and Emanations of “Jacob’s Ladder” portrayed by the Kabbalist *Tree of Life*.

Schema: First are delineated the relevant paths of the *32 Paths of Wisdom* together with some of their attributes as given in *The Keys to Kabbalah*. Immediately following are descriptions of the Seven Heavens as described in *The Testament of Levi*, generally placed by scholars as having reached its present form some time between the destruction of the Temple in Jerusalem in 70 c.e. and the final Jewish revolt in 135 c.e.

PATH 10: The Resplendent Intelligence. The Heart of Understanding and the Foundation of Wisdom. The Child in the Bosom of the Mother as shown in the Icon of Hagia Sophia (Holy Wisdom) in the Church of that name in Istanbul (Constantinople).

THE SEVENTH HEAVEN: Here dwells the Great Glory, in the Holy of Holies, far above all holiness.

PATH 13: The Inductive Intelligence of Unity. The Heart of Mercy, wherein dwells the Holy Spirit. The Foundation of Understanding.

THE SIXTH HEAVEN: Here are the angels of the presence of God, who minister and make propitiation . . . for all the ignorance of the just; and they offer . . . a sweet-smelling savour, and a bloodless offering.

PATH 16: The Triumphant and Eternal Intelligence, the Delight of Glory. The Foundation of Mercy and the Heart of Strength.

THE FIFTH HEAVEN: Here are the angels who carry the answers to the angels of the (divine) Presence.

(This being the station of priesthood in the church, a correspondence can be seen here with this “message-carrying” intermediary function.

PATH 19: The Intelligence of the Secret of Spiritual Activities. The Foundation of Strength and the Heart of Mediation.

THE FOURTH HEAVEN: Here are the Thrones & Dominions in which hymns are ever offered to God.

PATH 22: The Faithful Intelligence, in which spiritual virtues are deposited and augmented. The Foundation of Redemption and Mediation, the Heart of Victory and cyclic activity.

THE THIRD HEAVEN: Here are the hosts of the 'armies' which are ordained for the time of judgement, to deliver justice (divine vengeance) on the spirits of deceit.

PATH 25: The Intelligence of Temptation or Trial. The Foundation of Victory and cyclic activity and the Heart of Glory.

THE SECOND HEAVEN: This has fire, snow, ice, ready for the day of the divine ordinance, in the justice of divine judgement.

PATH 28: The Active Intelligence, wherein is created the spirit of every creature. The Foundation of Glory and the Heart of the Foundation).

THE FIRST HEAVEN: This, the lowest, is the most gloomy, in that it is near to all human iniquities.

NOTES

From the text of The Testament of Levi:

The seer sees seven figures in white clothing, who say:

Arise, put on the robe of priesthood, and the crown of righteousness (uprightness, justice) and the garment of truth, and the diadem of faith, and the tiara or miracle, and the ephod (vestment) of prophecy.

"And the first (*Path 28*) anointed me with holy oil (*pre-baptismal*) and gave me the rod of judgement. The second (*Path 25*) washed me with pure water (*baptism*) and fed me with bread and wine, the most holy things . . . The third (*Path 22*) clothed me with a linen vestment, like an ephod (*post-baptism*). The fourth (*Path 19*) put a girdle round me, like purple. The fifth (*Path 16*) gave me a branch of rich olive. The sixth (*Path 13*) placed a crown upon my head. The seventh (*Path 10*) placed on my head a diadem of priesthood, and filled my hand with incense, so that I served as a priest . . ."

Levi later adds that he has 'learned from the writing of Enoch,' about which learning he discourses at some length. A significant passage is, referring to the high priest, a possible prophecy concerning the coming of the (or a) Messiah:

"And he shall open the gates of Paradise [*Briah*] and shall remove the threatening sword [*Path 19*] against Adam (*Humanity*) and he shall give to his saints to eat from the Tree of Life [*Jacob's Ladder and the Seven Heavens*] and the spirit of holiness shall be upon them."

There is also a highly relevant conclusion reminiscent of the Two Ways of the Didache, or Teaching of the Twelve Apostles, as well as the Letter of Barnabas and the Shepherd of Hermas (Apocryphal New Testament writings):

"And now, my children, you have heard all; choose therefore either the darkness or the light, either the Law of the Lord (*YHWH*) or of the works of Beliar."

APPENDIX 3

WAKING UP TO LIFE

(or, It may not be Auntie Lulu)

1. The Human Trinity

We all tend to think of ourselves as single, unique individuals, and essentially this is true. What we may be mostly unaware of is that our human nature during our passage through this world of time and space is a composite of three basic natures, only one of which may be regarded as the essential "I" for each one of us. Religion has classified this threefold nature as consisting of body, soul, and spirit, which is as convenient a way as any to think of it. The way in which these terms are used here may not coincide with the orthodox religious view, but it may be verified by experience,

whereas much of the religious thought properly belongs in the realm of philosophy, which in its practical expression is more concerned with ideas and hypotheses than with verifiable experience.

Body

Firstly then, let us consider each of these three categories separately. The human body is an incredibly complex mechanism, and modern science has discovered things about it and its components which make miracles look like party tricks. This has led some people to regard the totality of the human being as no more than an incredibly complex and wonderful expression of our multi-miracled physical nature.

Body is composed, as most of us know, of this extraordinary complicated arrangement of flesh, bones, blood, and nerves, all of which are fed in various and often subtle ways. Mostly, however, it is self-regulating, and once we have taught it to walk and talk, we can safely rely on it to take us to and from the places we wish to visit, be it the kitchen or some far country on the other side of the globe.

Stop for a moment and consider your own body. Are you your legs? Your arms? Your liver? Hair, ears, eyes? Very simple observation makes it immediately apparent that you are none of these things. Are you any two, three, or four of them bundled together? Clearly not. Why then should we suppose that however we add up the various physical components of the human body, its totality of parts adds up to being you or me or anyone else?

So, though we may each, individually, be genuinely unique in that I am not you and you are not me, we are clearly not our bodies. We have bodies, it is true, and perhaps because no two bodies are identical in every respect (not even in the case of “identical” twins) we tend easily to identify with them. When a friend or loved one dies, we speak of their remains being disposed of in personal terms. We say that so-and-so, using his or her name, has been burned or cremated, but this is not true, it IS only their REMAINS that have been so treated. They are demonstrably no longer present.

Body, then, may be regarded as an incredible and wonderful machine by means of which we are able to move about and experience the world, but that is all it is. It is not us, but a valuable possession which serves us as well as it can, but only for our natural life span in the world. To use a modern term, its “shelf life” rarely exceeds a hundred years.

Soul

Soul is often regarded as being the essential, immortal or eternal part of our nature which we can clearly and truly identify as “I”. Unfortunately the term “Spirit” is also used in the same way by different people, so that it is essential to understand the way in which the use of the word soul is employed here.

Mystics, psychics and others have for a long time spoken about a second “body” of an “ethereal” nature, which has also been given various names, such as the “astral” or “etheric” body. That such a FORM (to distinguish it from our use of “body”) exists is virtually undeniable. To people who have had conscious experience of it its existence it is totally undeniable!

Quite ordinary people have had what is called the “Out of the body” experience, so our testimony does not depend upon the witness of mystics and psychics alone.

Under ordinary circumstances this subtle form may indeed be regarded as analogous to a second “body” but there is more to it than just this function. In appearance it is often described as a kind of misty replica of the physical with which it normally coincides and interpenetrates. The out of the body experience occurs when someone wakes up in this subtle form at a time when this coincidence of place is not happening. The most startling experience to have is to be in this condition and from it to be able to look at one’s own physical body lying asleep in the bed, breathing away as usual - snoring even - and to realise that you are not in it, but somewhere outside it, in another state of being.

This other state of being, where we exist in this subtle form in-dependently of the physical, is what is meant here by “soul”. Or rather the subtle form itself is “soul”. Because of the confusion in many people’s minds between the terminology of soul and spirit, we shall use a term which is in fact found throughout the Hebrew scriptures (the “Old Testament”). The reason for using this term, NEPHESH, is that this seems to have been precisely what it meant to the ancient Hebrews. When we read the English word “soul” in our translations of the books of the Hebrew scriptures, we are almost certainly reading a translation of this very word.

This subtle form, this Nephesh or soul, appears to subsist for a time after the death of the physical body, but is essentially linked to it during earthly life, and is possibly another energy source for the physical. This subtle form, the Nephesh, separates from the physical to a greater or lesser degree during sleep. When a person separates some distance from the physical in this state, and then wakes up, then this is when we experience one form of the out of the body experience. Under normal everyday circumstances however the two “bodies” - the physical and the Nephesh - clearly work in tandem. The Eastern system of “chakras” or “psychic centres” relates to the Nephesh, and we shall return to this later on. To be more accurate, it is not a “system” at all, but a description of psychic fact. It is interesting to observe that the word psychic also concerns the “soul”, as it derives from the Greek word PSYCHE, also translated as “soul” in scripture. It is also the root of the word “psychology”.

Spirit

Spirit, as used here, actually does refer to the essential, immortal, eternal human essence which each one of us IS. For the moment there is little more to be said about it, except to say that it is the Spirit which HAS a Nephesh, and which HAS a body.

2. The Human Animal

That’s what the body is - an animal, a beast or creature among the other mammalian creatures such as apes, dolphins and whales. Furthermore, our bodies have a limited intelligence of their own, an intelligence which is of a very basic nature. Its main requirements are simply food, warmth, shelter, and sex.

Without the animating Nephesh which actually makes it both alive and human, it is no more than a collection of meat, bones, blood, nerves and so on. In a sense it might be said that we, as human beings, are parasites living within this animal host. Clearly we have to treat it with a reasonable amount of care and respect, as without it we cannot function in this material world at all. At the same time, it quite clearly has a will of its own, as well as needs, desires, and functions which can more often than not be a definite nuisance in our attempts to follow our own will in preference to its. Even astronauts

exploring the glories of space have to make provision for urinating and the passing of excrement! Such is the paradoxical grandeur of the human race and its achievements.

However, provided we make suitable and sensible provision for the body's needs, it makes little demands upon us, and we are free to use it to explore the wonders of planet Earth. And it is our temporary stay upon planet Earth which is the main concern of this treatise. We may well - and do - speculate on where we were before we were born, or where we will be after death, but in the meantime there is plenty to do, a great deal to explore, exciting (and not so exciting) things to discover and learn. Discovery and learning - are these not the main preoccupations of all of us? Did you ever meet a human being who did not want to know about something?

The animal creature with whom we have a sometimes uneasy alliance may share a certain amount of this curiosity with us, but its version is severely limited to those basic needs mentioned above. Ours is far more complicated and ingenious. Let's put it this way: the animal will be content to discover the nearest corn-field, grab the husks of wheat, just as they are, and stuff them into its mouth. The human soul or Nephesh dwelling in and along-side it will, in the course of the same discovery, eventually go on to invent the pop-up toaster. The greater part of our human existence therefore is clearly determined by the needs and curiosities of the Nephesh or soul nature by means of which we are able to co-exist in a uniquely human way with the creature.

Human Mechanics

By and large then, the human body can safely be left to take care of itself, sending us appropriate information as and when it sees its needs as being neglected, as in the need for food and warmth for example, or if it is a state of disorder, when it sends us signals of pain or distress. Because we spend our lives surrounded by the manifestations of material existence, we fondly suppose that we live in the "real" material world. All we ever see, however, is the outward appearance of things, their surfaces. When we look at a tree, we do not see the inside of the trunk, or the sap - the life blood of the tree - rising and falling; nor do we see the internal workings of the other human bodies among which we pass from day to day.

Obvious as this is, it is true to say that even if we could, we would still be seeing only yet another surface appearance, for science has demonstrated that in the material world, even within the surface of the immediately interior object - such as the ordinary human heart - there is a material activity of molecules and atoms which can only be seen with the aid of another material, mechanical device such as a microscope, with its interior molecules and atoms.

What we are most unlikely to see in any of these things is the life-energy which gives those same molecules and atoms their ability to function. What we have been able to discover is that all these things are subject to laws, each according to its kind. (cf. the Creation accounts in the Book of Genesis). Essentially, therefore, the human body, with its incredible complexity, is a mechanical device animated by - WHAT?

How much of the "real" world do we actually see? Very little, most of the time, unless perhaps we are in a strange place whose surroundings are unfamiliar to us. In our own neighbourhood, are we normally aware of the local tree, with or without its sap, or is our attention elsewhere? It is elsewhere, invariably occupied with thoughts and images circling round in the mind.

3. The Human Mind

What is this mind? It is clearly more than the aggregate of human brain and nerve activity, though damage to these areas can seemingly affect its ability to communicate quite seriously. However, it has been established that people who are physically paralysed or otherwise disabled and unable to communicate because of such damage, are likely as not as lucid and intelligent - sometimes more so - as anyone else. We have all seen television programs which demonstrate this, where someone with an apparently crippling complaint has been able to demonstrate that there is nothing wrong with their minds whatever, once we have been able to provide them with mechanical or electronic aids which compensate for their disability. Mind, then, is clearly not dependent upon totally efficient physical mechanisms in order both to function and to exist. Mind is a function of Nephesh, or soul; and because most of our waking lives - and probably a large part of that one third of our lives we spend sleeping - are spent engaged in mental activity, the living human being is, in fact, not a physical creature at all, at least, not as ordinarily understood.

Anyone can easily demonstrate this fact for themselves. When we are on our way to the local shopping mall, passing trees and other familiar landmarks, our attention, our thoughts, our imaginings - these are ahead of us, already at the store, buying various items, debating which ones to get, picturing ourselves actually taking items from the shelves, calculating the cost, etc. The existence of the local tree occupies only a minimal part of our attention, and then only in passing.

In short, we are not, in the ordinary course of events, fully aware of our material surroundings at all. We live, as the popular saying recognises, "in a world of our own."

Motivation

What we perceive as mental activity, be it thinking in words or imaging (imagining) in pictures, is an activity operating within the soul, the Nephesh, and it is this activity which "animates" the body.

When we are very small babies we have no control to speak of over our bodies. As we learn, by responding to the various stimuli we receive from our parents, guardians, and surroundings, we are receiving information directly into Nephesh, and are able to form images and sounds to imitate. Thus we become able to walk and talk, and increasingly, to think, to reason and calculate. For example, by watching the way in which other people walk, the child takes the image of this into its mind; the immediate result of this is translated directly to the body, which attempts to duplicate what the image has informed it. Gradually the body learns, and we begin to take our first wobbly steps in the material world. The same process is repeated for all other human activity, increasing in complexity and subtlety for all of the necessary activities of everyday life as we grow older.

The innate curiosity which, in many ways, actually identifies us as human beings rather than some other species, does, from an early age, begin to use its imaging facility for speculation, and becomes able to do what we ordinarily call imagination, whereby we are actually able to postulate images in the mind/soul/nephesh of objects and scenarios which do not, and possibly cannot exist. Imagine a pigeon with a cow's head - anyone can do this. Imagine winning the lottery, or inheriting a fortune - easy, fun - but unlikely.

First thoughts

A little intelligent observation will soon show us that the first kind of thought we have is, in fact, an image, a picture in the mind. Once we have learned to talk, using language to describe the picture that we image, we have discovered a kind of shorthand labelling method. For example, the word “pigeon” used above calls up from memory the whole bird, complete with feathers, stick-like legs, beak, and funny walk. Substituting the cow’s head for that of the pigeon involves a whole series of complex imagining, but we can do it, using the same basic mechanism, provided of course we already have images of pigeons and cows in our memories.

As we grow older, the use of this language shorthand becomes second nature to us, so that the transition from image to “thought” is so fast as to be imperceptible. What we mostly perceive as first thoughts are, in fact, second thoughts!

Making an Impression

While the body provides us with the means of moving around in the world, the nephesh-soul-mind activity provides the means of identification and communication concerning what we discover in it. There is a definite and clear sequence to this activity which fairly simple observation of our own behaviour will soon demonstrate.

Whatever we encounter in our experience of the world makes an impression upon us - we actually use this expression to describe this activity in common speech, though only when the impression made seems to us to be particularly striking. It is worthwhile reflecting on the colloquial use of language, which often seems to instinctively describe quite accurately what is actually taking place.

Making an impression, in another context, is as when, for example, we leave our fingerprints in a piece of wax or similar material. Later we can re-examine the wax and find the record we have left there.

So it is with the multitude of impressions we receive every day. It seems that, in a quite literal sense, all the objects and people we encounter leave an impression in the subtle “body” we have called Nephesh. This is the basis of recall and the ability to remember things and people.

First Impressions

Here is another everyday term with which we are all familiar. What happens with “first impressions?”

In basic terms, a simple process immediately ensues. Under average conditions we encounter an object or person, sound or sensation, which, on making its impression, causes an immediate reaction in us. The essential quality of “first impressions” that we are all familiar with is summed up in sayings such as:

“My first impression was that I didn’t like the look of them.”

“Something about them didn’t feel right.”

“She gave me a good feeling.” The impressions events and people make upon us are received by us, in the first instance, as a feeling or feelings. Basically, our reaction is invariably a greater or lesser degree of “like” or “don’t like.” At the same time this feeling is translated into an image which approximates to the nature of the impression.

Consider that the Nephesh is something like the wax: in making the impression, there is a direct reaction from the wax to the pressure we have placed upon it with our fingers. Any impression we receive acts in a similar way - it "makes a dent" in the Nephesh. We are, to use another well-known phrase, "impression-able."

The most important thing to note however about these first impressions is that of "like" or "dislike" - a reaction which does not depend upon reason or logic. This is because the first part of the impression process goes directly to our memory store of images for immediate comparison. If, for example, we have been hurt, whether physically or emotionally by something in our experience which merely resembles the image of the impression we are receiving, then our "first impression" will be one of dislike. Similarly, if the memory store comes up with pleasantly similar images, then our reaction will be one of liking.

Only after this process has taken place - which takes minute fractions of a second - do we refer the impression to the ordinary intellectual mechanism, whose principal function is to search its memory store for suitable labels with which to name the impression. If, for instance, the impression is that of a person whom perhaps we have not met before, the label that may be delivered to our awareness may be something like, "similar to Auntie Lulu." BUT - and this is an important "but" - the label we receive will have already been conditioned by how we feel about Auntie Lulu in the first place.

Only after the like/dislike mechanism has operated, and a tentative label has been assigned to it will we actually do anything. The basic process then is "Impression - like/dislike - label (identify) - act."

It follows that, in the example above, we will recognise that the person from whom we are receiving is not actually Auntie Lulu, but someone who resembles her. But "Auntie Lulu" is an emotionally affected label, and in consequence our behaviour towards the strange but similar lady will be affected accordingly, and we will suspect that she will have some of the attributes which we have assigned to Auntie Lulu.

If we like Auntie Lulu, we will tend to act in a friendly manner to this lady, as if we expect her to behave in a similar manner to Auntie. If otherwise, we shall be more cautious about her, and we dislike Auntie Lulu intensely, we may even avoid her completely. It is, of course, highly unlikely that this lady will resemble Auntie Lulu anything like as much as we imagine, or even at all.

It is, however, extremely probable that given the above scenario - which we can investigate and verify by observing our own nature and behaviour - that we rarely see the "real world" as it actually is at all; that we rarely relate to other people as they really are in their own true natures; that all we see and experience is interpreted by the mechanism of the human personality in terms of our previous experience and acquired prejudices. In short, we are living in a world of imagination, endowing our environment with attributes it may or may not possess, and even if it does, probably not in the way we imagine.

In short, we spend most of our lives daydreaming; we are, in a manner of speaking, "asleep" but believing we are "awake" - an approach used by the philosopher and esoteric teacher P.D.Ouspensky.

If, then, I say that under these circumstances I am "asleep" then who is this "I" who sleeps? It is not the "I" of the personality ego-mechanism, but the "I" of the soul. In

short, Nephesh sleeps, and I am, in a large measure, a walking, living, breathing automaton. What price “choice” and “freedom” if these are exercised under such circumstances? Clearly we have little of either. The remedy is simple - we must discover how to “wake up” as Nephesh, as “Soul”. Only then do we have the chance to make real choices and exercise genuine freedom.

Waking up

This is where we come to the practical side of this study, and this work, with the emphasis on work. Most things worth achieving require effort - it is necessary to put the theory into practice. (There ain't no such thing as a free lunch). You will recall that earlier on it was said that all that has been described may be verified by experience. This experience, however, does not come for the asking - it is necessary to go and get it.

In this section, and by way of a temporary conclusion, we shall describe the first steps that anyone can take on their own, to put the theory to the test. When the preliminary work has been begun, and has become a natural activity which can be undertaken at any time simply by remembering to do it, then it is possible to move on to a deeper understanding leading to a greater knowledge of one's true nature and identity. This next level of working is, by its very nature, not something that can be written down as a simple set of instructions, and needs to be followed under supervision, In company with others who are travelling on the same road, which is why we can only reach a temporary conclusion here. Like most disciplines, the practice which can be given here begins with learning how to quieten the ceaseless mental activity of the labelling mechanism, which is chattering away all the time like a monkey in our heads.

The first step

Choose a quiet time, where you can feel and be relaxed. If possible, sit upright on a straight-backed chair, and let the eyes close. Give your attention first of all to your body. Feel its weight on the chair, the texture of your clothing under your hands, wherever they are resting, and be aware of the sensation of your clothing touching your body underneath. Feel the floor beneath your feet - maybe you will want to take your shoes off.

Once you have established a clear awareness of your own physical nature, then relax as much as possible. Take two or three deep breaths to help the relaxation process. Now let the eyes close. This is a subtle, but useful point: do not positively shut the eyes, but simply allow the lids to gently lower themselves.

Now - listen. Just that: in the very ordinary way, just as you might when enjoying a piece of music, allow the various sounds in the room - a clock ticking, perhaps, to take your attention. Extend this hearing activity to include as much as possible of whatever sounds there may be within earshot - traffic outside in the street, perhaps a bird singing, a dog barking - whatever there is physically to hear.

Very soon you are likely to find yourself having various thoughts about the sounds you hear, and quite possibly wandering off into the daydream we spoke of earlier, so that you stop being aware of the sounds around you. Whenever this happens, and however often it happens, STOP IT. Start again from the beginning (although it is not necessary to open your eyes again) and give your attention to the physical sensations, and then the sounds around you.

It is important to note that the purpose of this practice is not to achieve an immediate objective, such as remaining fully aware of your physical situation and the sounds round about without interruption for as long as possible. Indeed, the main value of this practice is to become familiar with the way in which the intellectual labelling mechanism keeps taking you over and causing you to slide unconsciously into daydream, and to learn to stop it from doing so when you wish to.

Every time you notice this has happened, you have woken up for a moment, and in so doing, you very quickly become aware of your own situation and the noises in your vicinity - the genuine “real world!” Practice this exercise about twice a day if you can, for about ten minutes at a time. Gradually you will become more proficient at catching yourself “falling asleep” and going into daydreams, and every time you do this you will have woken up a little more.

The same but different

Another way of practising what is essentially the same technique is to apply the same principle to the ordinary activities of everyday life. This, at least to begin with, is more easily done out of doors. There are several ways of applying this technique, of which we shall give two. With practice, you will begin to discover other ways of applying it that are suited to your own situation and temperament.

First, then, find a suitable outdoor location - it can be almost anywhere, so long as you can find a suitable place to sit down. A park bench perhaps, a low wall, even a seat in the local shopping centre. Practice the same exercise as you did (and are certainly still doing) when indoors, except that this time you keep the eyes open while listening, and at the same time give your attention to what you can see around you as well. Again, whenever thoughts intrude and begin to take over, STOP THEM. You will have woken up again. If the place you have chosen has a good view, then extend your visual awareness as far as the eye can see, and endeavour to visually take in as much as possible, all at once. Do not let your attention fasten on to any specific sound or object, but without going off into a daydream, keep the attention as wide as possible. Once again, but this time more so, you will find yourself wide awake in the real world!

The second form of this exercise is essentially the same as the first, except that having grasped the basic practice through the previous listening and seeing exercises you learn to open your attention up as wide as possible whilst walking to or from a place which is a regular destination, in or out of doors, though like the previous version, it is more effective outside than in, as there is more to see and hear, more to be aware of.

Gradually, or even not so gradually, you will appreciate more and more the joy of simply being alive and present! You are awake!

Having experienced this, you will readily appreciate that there is one thing that no book, no lecture, can ever do: it cannot tell you what it feels like, for that is something that can only be experienced. It is a subject for doing, not for talking or thinking about. It is a waking up to life

Church and Temple Supplement

THE LADDER, THE CHURCH, AND FREEMASONRY

Some time around the latter part of the 11th all of the 12th century, and a little way into the 13th, the great Abbey and Cathedral churches of Europe began to be built.

No one can say with any degree of certainty why this work began when it did, but we can with certainty draw attention to a number of coincidences attached to it.

Firstly, by this time it was certain that the great Christian Crusades, in the service of the Roman Catholic Church, to take the "Holy Land" of Palestine by force for "Christendom" had failed. What cannot have failed to occur during a century of combat between the warrior knights of Europe and the inhabitants of the land they sought to conquer was a large degree of contact and even fraternization. Their main enemy was Islam, the religion of Mohammed, but then, as now, there were a large number of Jews living and worshipping there. That some of the contact will have involved a sharing of religious concepts and beliefs is equally likely to have occurred. On the Islamic side there was a strong alchemical tradition among some of the peoples of the Islamic, Arabic-speaking countries. On the Jewish side there was the long and strong traditions of Jewish mysticism, of which Kabbalah would have formed a major component, even if the term itself were not yet in use - though with the publication of the Zohar before too long, the word would quickly enter the esoteric, occult, and mystical languages.

The crusades being over, those in positions of influence and power (for a short time when the outcome looked more hopeful) will have returned to their various European homes. Did they, perhaps, bring back something more with them than their rusting shields and blunted swords?

Whether they did or not we cannot say, but it is demonstrable from the geometry of the new Abbeys and Cathedrals that they, or their contemporaries, began laying out the plan of "Jacob's Ladder" as delineated in these pages according to the exact proportions we have shown. Originally, all these buildings would have had a monastic foundation, and by virtue of this, have been the only schools of their time. Admittance to such schools was not a state requirement or even a state concession, but was governed solely by the considerations and need of the Church. In nearly all of the examples so far examined, there is the equivalent, in Christian terms, of the porchway entrance of King Solomon's Temple, though defined in a different way.

Although the Abbey Church was entered through the West Door, there was a lobby immediately inside where, we could suppose, potential catechumens might wait - maybe for some time - a decision on their acceptance or rejection by the establishment. In this area in some churches, including local parish churches, would have been found the initiation essential, the baptismal font. It is still in this location in many an old English country church, although the fashion is to have it closer to the altar in more modern times. Once initiated, the spiritual entrance was open, and so we find that Path 32 of the Ladder is often just inside the building.

Supposing, for the sake of conjecture, that the Church *knew* it was building an exact and meaningful symbol of the ancient mystery teaching, then might it not have required a work force that had to be given at least some of the secrets of that teaching in order to ensure that the building work was constructed *exactly* as required, rather than the approximation that even today accompanies the work of master builders? Bearing in mind the almost total power of the Roman Church in Europe at that time, the best way of ensuring the accuracy of the work might well have been to attach to the elements of the Teaching that were given to the builders some awful penalties that would be enacted if they failed to behave - just the kind of penalties that are said to have existed in, firstly, operative Freemasonry, and later, speculative Freemasonry (such as is the only known form of it today)?

Regardless of these conjectures however, it is certain - and demonstrable - that the ground plan of these buildings still matches the plan of the Ladder as it has been outlined here. From the masonic point of view, where there can be a maximum of thirty-three rather than thirty-two paths or degrees, we can discount the apprentices, who, like the potential catechumens, would have had such little preparation as was permissible given to them in the lobby mentioned above, or even outside the building altogether. Of the actual craft and higher degrees there would then remain just thirty-two, except that their order would follow the reverse numbering of that used in our specifically kabbalist diagrams. Counting backwards, the masonic eighteenth, or "Rose Cross" degree falls precisely and exactly on our Path Sixteen, where is to be found all the symbolism of the Cross, including the Hebrew letter for a cross, the Tau. Historically, it seems as though the earliest foundations came to an abrupt halt at Path Ten, "The Resplendent Intelligence," with the altar often being placed here hard up against the East wall of the building. In one or two English churches this is still visible from an architectural perspective, and at Durham and York

remains so, as the geography of their location makes it physically impossible to extend further eastward without falling down the hill.

Intriguingly, even awesomely, the same is true of the ancient Temple of Luxor in Egypt, whose date, in the diagram given here, is around 1600 b.c.e., or sixteen hundred years *before* the Christian Church had even been conceived, but later to be born out of the Israelite religion attributed to Moses, the lawgiver. The last word on this perhaps to leave us wondering and marvelling comes from the New Testament itself, in Acts, 7:22 - "*And Moses was trained in all the wisdom of the Egyptians.*"

The Temple of Luxor, Egypt

(circa 1600 b.c.e.)

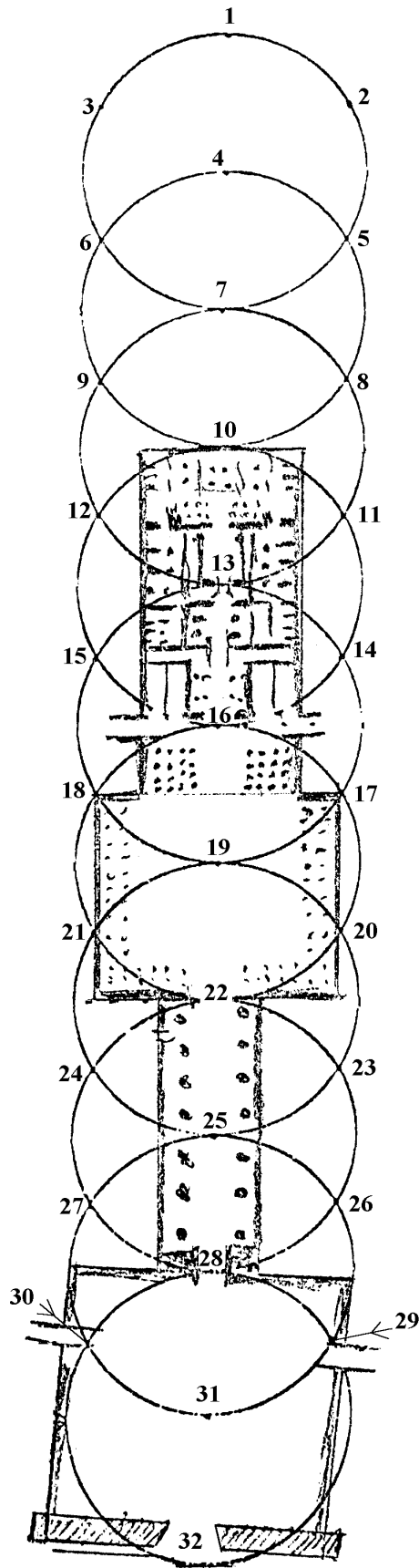

Glastonbury

Abbey

(c. 1185 c.e.)

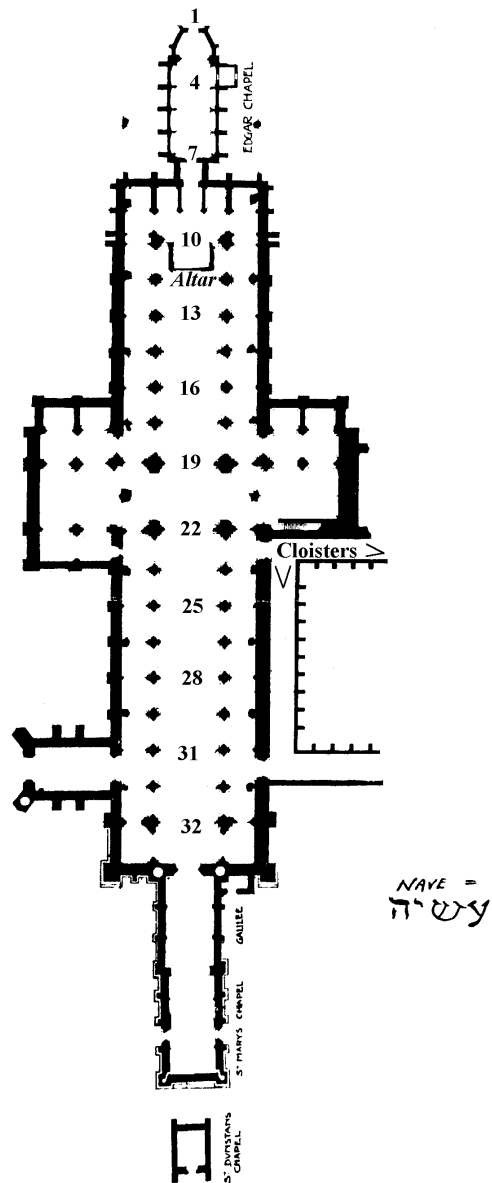

Durham
Cathedral
(1193 c.e.)

