



# DEMONSTRATION OF A MULTIMODE FIBRE-FED INDOOR WIRELESS NETWORK

*A. Das, A. Nkansah, I.J. Garcia, N.J. Gomes, J.C. Batchelor, D. Wake*

Department of Electronics, University of Kent  
Canterbury CT2 7NT  
United Kingdom

- INTRODUCTION
  - Current research
  - Aims of the project
- BASIC RoF LINK
- REMOTE ANTENNA UNIT DESIGN
- LINK BUDGET
  - Spreadsheet calculations
  - Results
- WLAN DEMONSTRATOR
  - Experimental set-up
  - Measurements
  - Results
- CONCLUSIONS
- FUTURE WORK

### □ Current research in low cost Radio over Fibre (RoF):

- MMF + 850nm VCSEL – Optical link performance characterised for RF signal transmission
  - Examples:
    - High SFDR achieved for RoF link using high-bandwidth MMF [1]
    - Transmission of WCDMA and GSM-1800 signals with minimum distortion over 50/125um MMF [2]
- MMF + uncooled DFB lasers (1300nm) – Optical and wireless link performance characterised for WLAN transmission
  - Examples:
    - Video signal transmission between the access point computer and mobile terminal achieved [3]

## ❑ Aims of research:

- Development of a low-cost technology for indoor wireless systems
  - Radio over Fibre → Radio over Multimode Fibre
  - 850nm VCSELs

## ❑ Specific objectives:

- Setting up of a WLAN system (*IEEE 802.11b* and *g*) demonstrator with acceptable performance using:
  - MMF (50/125um, 62.5/125um)
    - pre-installed in buildings
  - VCSEL (850nm)
    - commercially available
  - Wireless channel
    - Novel experiments and performance analysis of WLAN signal transmission over both the optical and wireless channels

# BASIC RoF LINK

## Central Unit

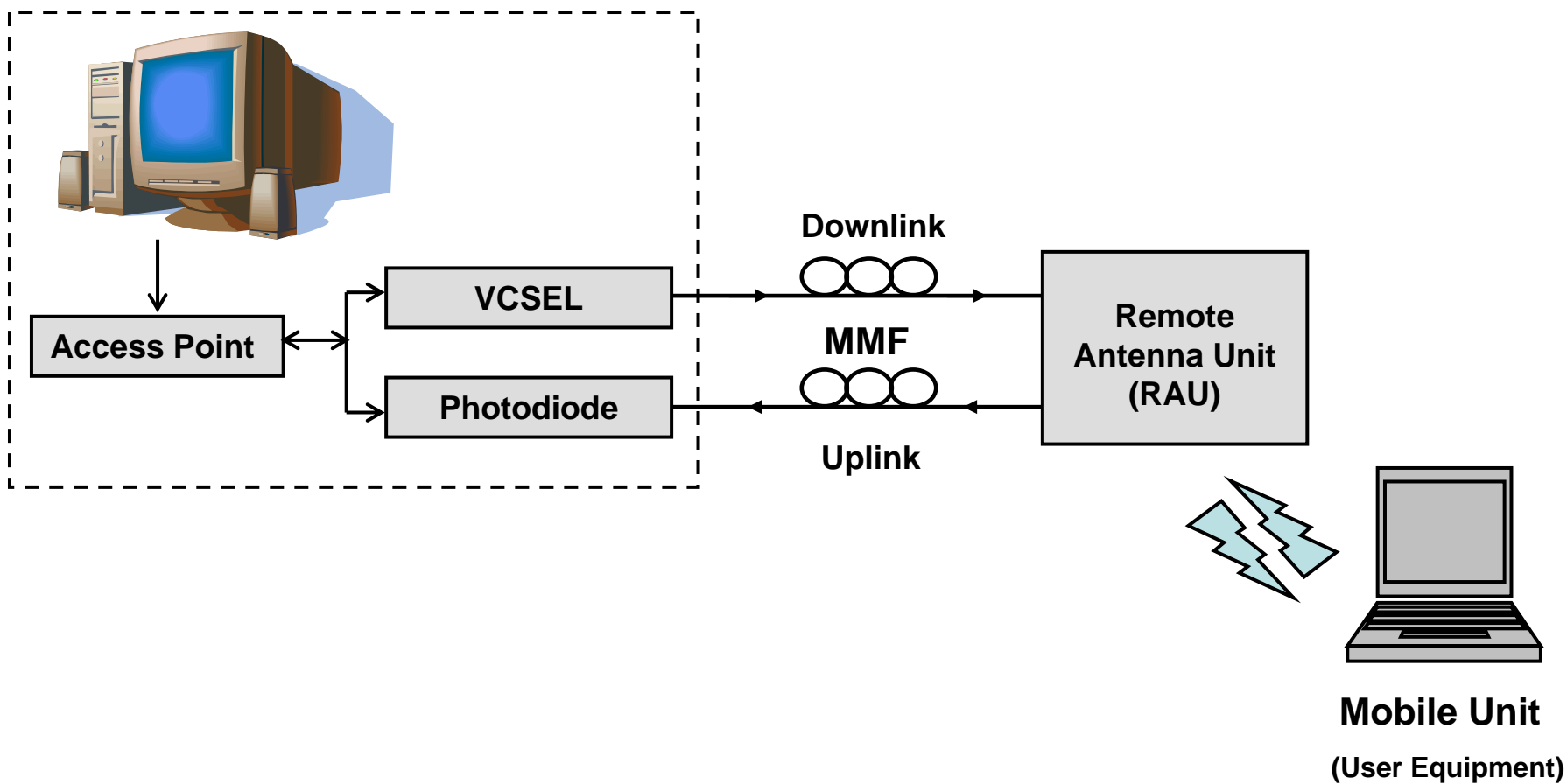

# REMOTE ANTENNA UNIT DESIGN

- A basic remote antenna unit design proposed using:
  - **Photodiode**
  - **VCSEL (850nm)**
  - **RF amplifiers**
  - Separate **Tx and Rx antennas** – co-located, omni-directional, multiband RF antennas designed specifically for the project by the Antennas Group, University of Kent

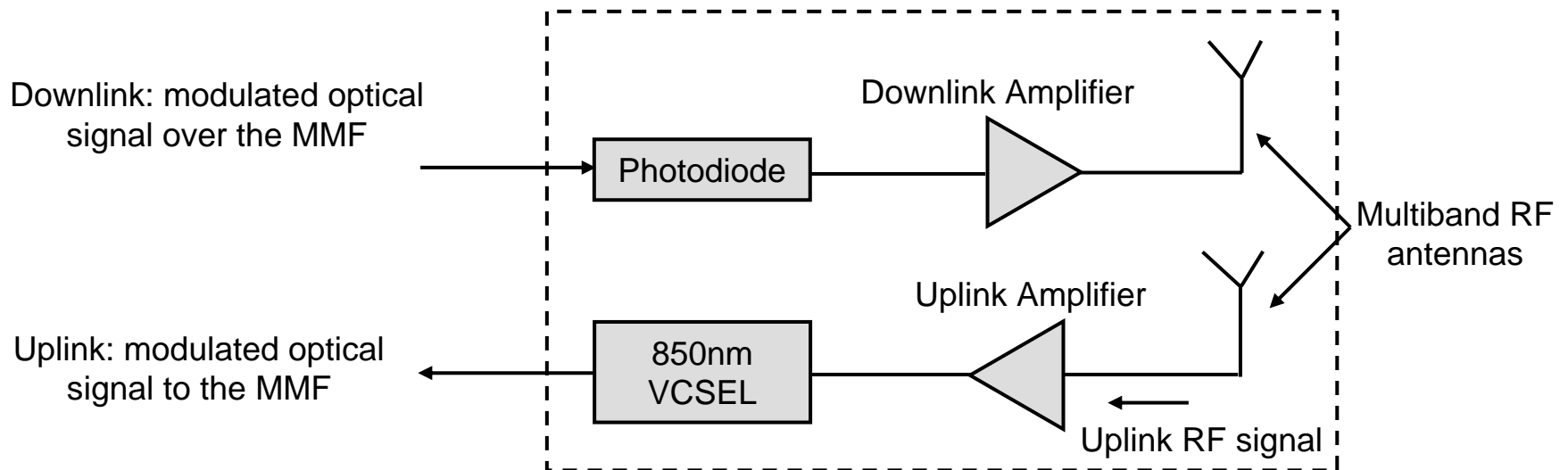

# LINK BUDGET

- ❑ Link budget spreadsheet – predicts link performance for the proposed RAU configuration

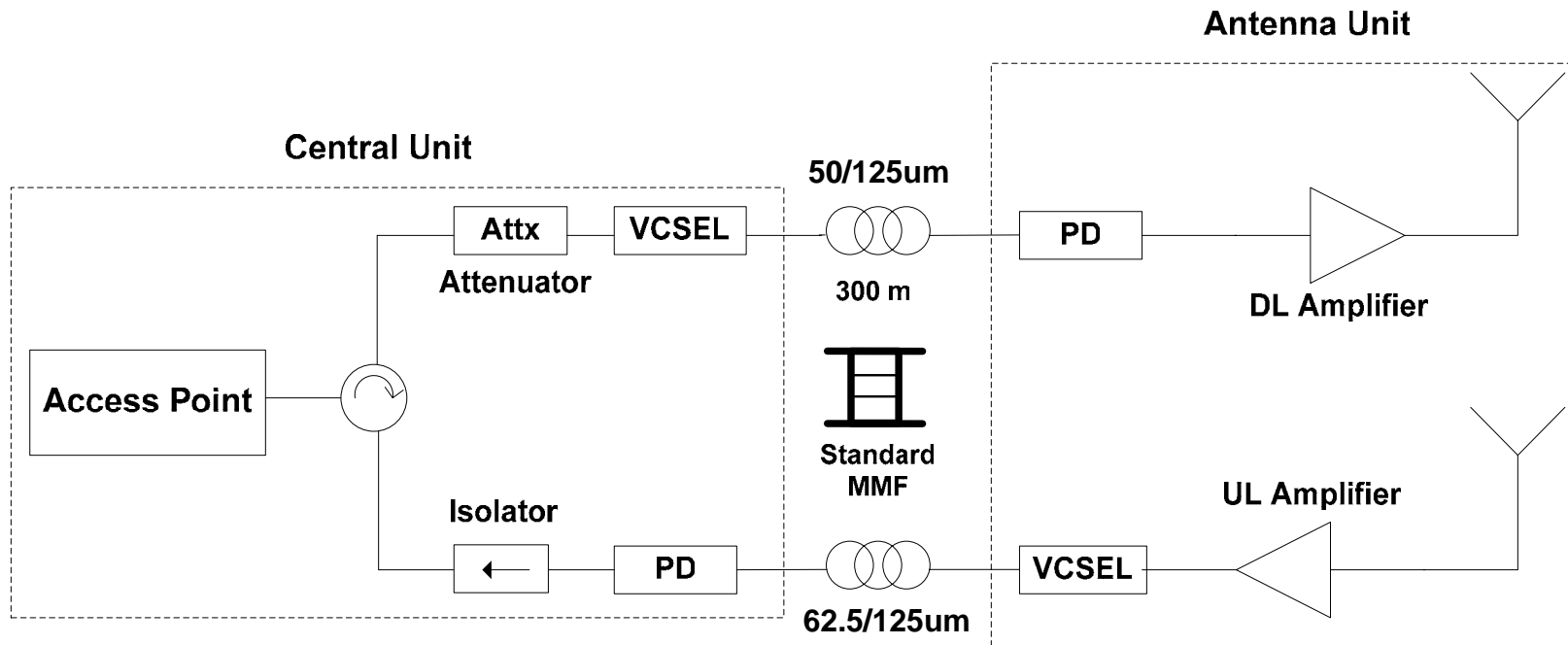

# LINK BUDGET CALCULATIONS

## ❑ Spreadsheet calculates:

- Path loss using Keenan – Motley model (dB) [4], [5] =  $20 \log \left( \frac{4\pi f}{c} \right) + 10 \times n \times \log(d)$

where,  $n$  = path loss exponent

$d$  = distance between the Tx and Rx (m)

$f$  = frequency (2.4GHz)

$c$  =  $3 \times 10^8$  m/s

- $n = 3.2$ , experimentally determined using propagation measurements for the target office room

- Maximum achievable range , both downlink and uplink
- Required amplifier gains

## ❑ Considerations:

- Cross-talk between DL and UL paths:
  - Loop gain  $> 0$ dB  $\rightarrow$  oscillation
- Minimum distance between mobile unit and RAU
  - Rx UL power after amplification  $<$  maximum input RF power to RAU VCSEL to avoid distortion
- Maximum allowed DL transmitted noise power

# LINK BUDGET CALCULATIONS

- ❑ Limitations imposed on the calculations:
  - Loop gain  $< -10\text{dB}$
  - Limiting UL Rx power at the RAU VCSEL: UL Rx power at the RAU VCSEL at a minimum distance of  $1.6\text{m} \leq -4.2\text{dBm}$
  - Transmitted noise power limited according to specifications for each standard
  
- ❑ Two antenna RAU preferred over a single antenna (Tx/Rx) RAU due to:
  - Higher isolation between the DL and UL paths → greater DL and UL amplifier gains  
→ greater maximum achievable ranges

# WLAN STANDARDS - PARAMETERS

□ A comparison of the two systems that were transmitted:

System	Frequency (GHz)	Access Scheme	Rx Sensitivity (dBm)	Noise Bandwidth (MHz)	Mobile Tx Power (dBm)	CNR (dB)
<i>IEEE 802.11b</i> (11Mbps) [6]	2.4	TDD	-82	11	17	7
<i>IEEE 802.11g</i> (54Mbps) [7]	2.4	TDD	-68	11	17	24.8

# SPREADSHEET CALCULATIONS

System	Range (m)	DL Amplifier Gain (dB)	UL Amplifier Gain (dB)	DL Tx Power (dBm)	Noise Power (dBm)	
					Calculated	Required*
<i>IEEE 802.11b</i> (11Mbps)	23 (max.)	38	25	1.8	-32.46	-30
	5 (target room) <sup>+</sup>	16.5	3.8	-19.5	-53.75	-30
<i>IEEE 802.11g</i> (54Mbps)	7 (max.)	35	25	-1.1	-35.34	-30
	5 (target room) <sup>+</sup>	30.5	20.5	-5.5	-39.75	-30

<sup>+</sup> Amplifier gains required to cover target room (6.2m X 5.6m) also calculated to validate spreadsheet calculations

\* Adjacent channel interference levels, as quoted in IEEE 802.11b/g standards [6],[7]

# REMOTE ANTENNA UNIT

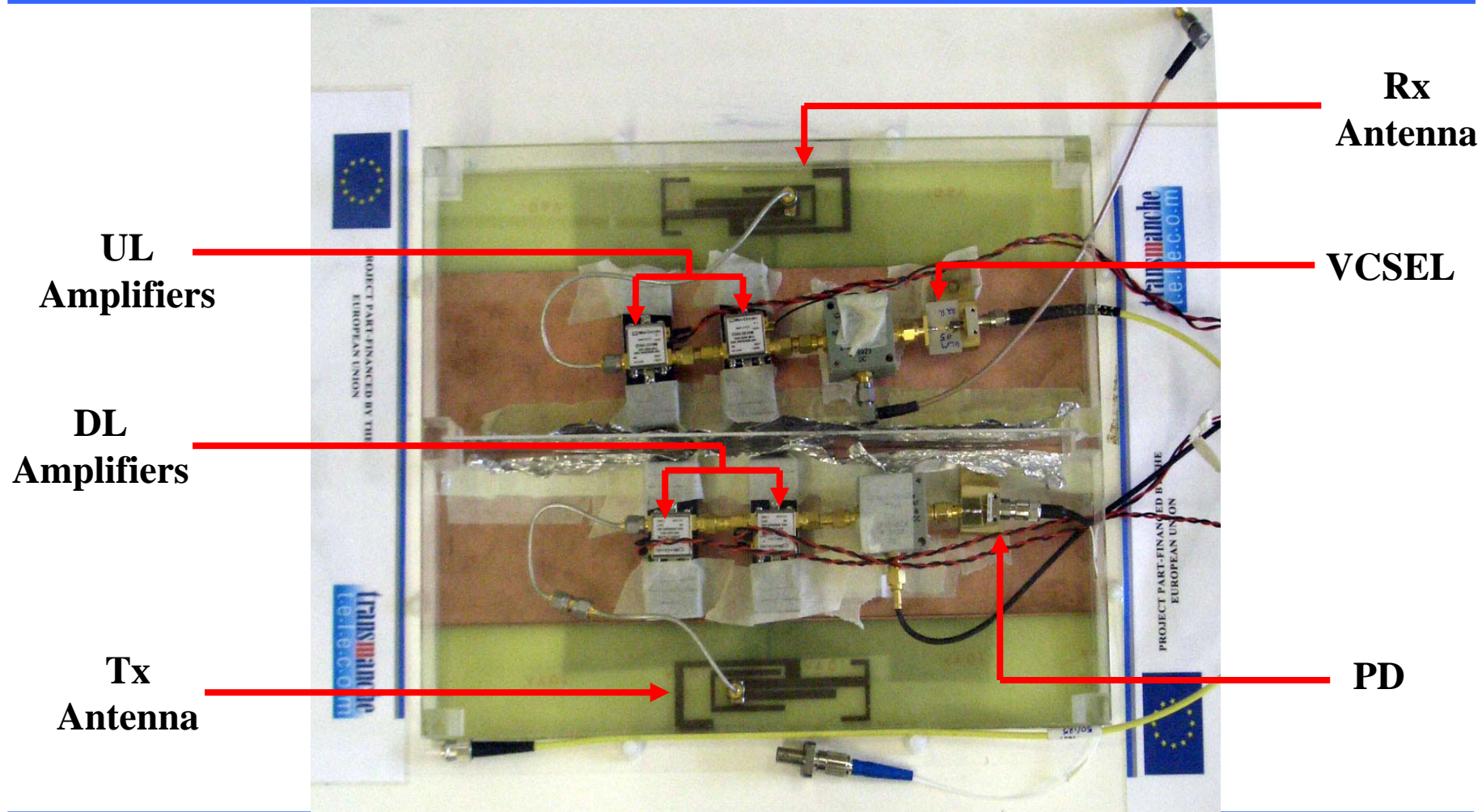

## Central Unit



## Remote Antenna Unit



## User with mobile unit

## Screenshot

**Wireless Device Details**

SSID: default  
 MAC Address: 00-0F-3D-0A-76-01  
 Encryption enabled (WEP)  
 Infrastructure mode

**Signal Strength**  
 -60 dBm [Very Good]

	Incoming	Outgoing
Average transfer rate	1.41 MB/s	30.5 KB/s
Maximum transfer rate	1.66 MB/s	35.8 KB/s
Total data transferred	23.2 MB	502 KB

**Wireless Network Connection 2 Status**

General | Support

Connection  
 Status: Connected  
 Duration: 01:05:28  
 Speed: 36.0 Mbps  
 Signal Strength: [Signal strength indicator]

Activity  
 Sent: 3,004,544 Bytes  
 Received: 140,283,490 Bytes

- ❑ WLAN components:
  - Access Point: *D-Link DWL-G650+*
  - Wireless card: *D-Link AirPlus G+ DWL-G650+*
  
- ❑ Demonstrator performance characterised by:
  - Received signal strength at the mobile unit
  - Throughput
    - Measurement time: 2 minutes
  - Measurement software:
    - *Windows Network Ignition*: signal strength
    - *Networx*: throughput

Received signal strength for IEEE 802.11b

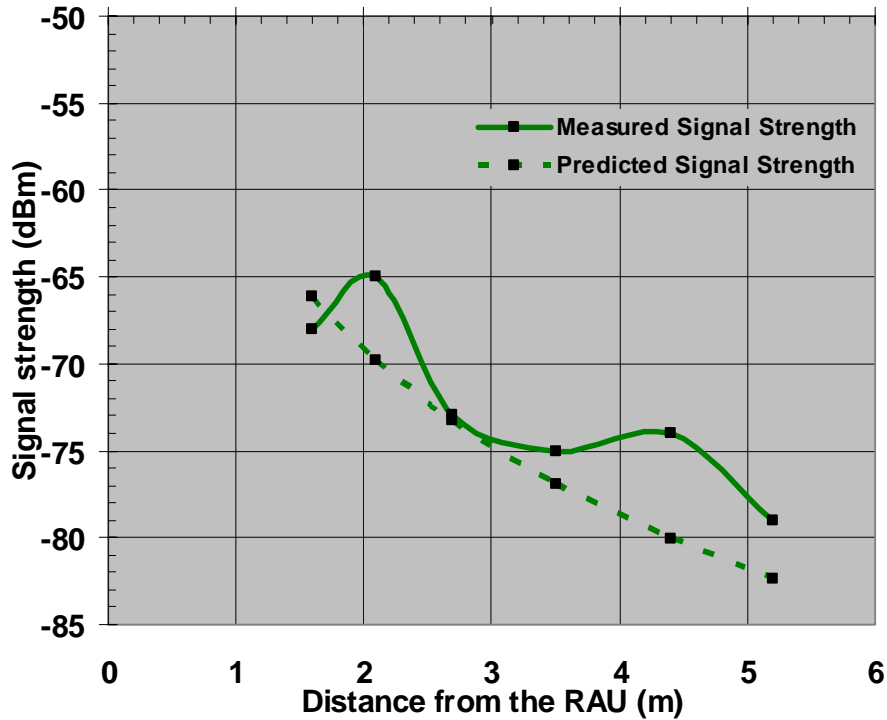

Received signal strength for IEEE 802.11g

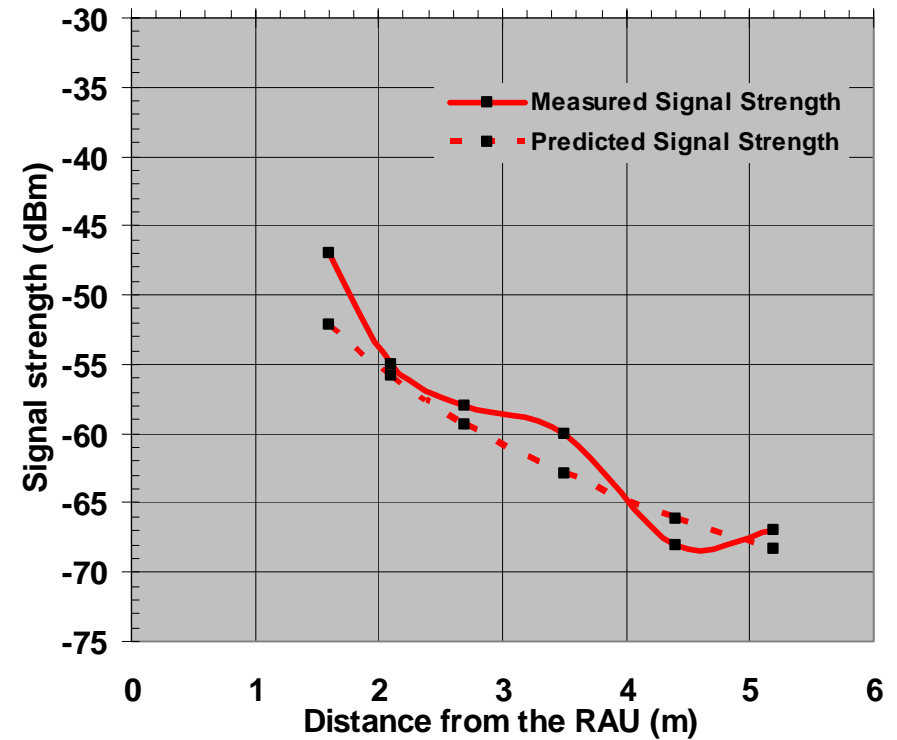

Throughput measurement for IEEE 802.11b

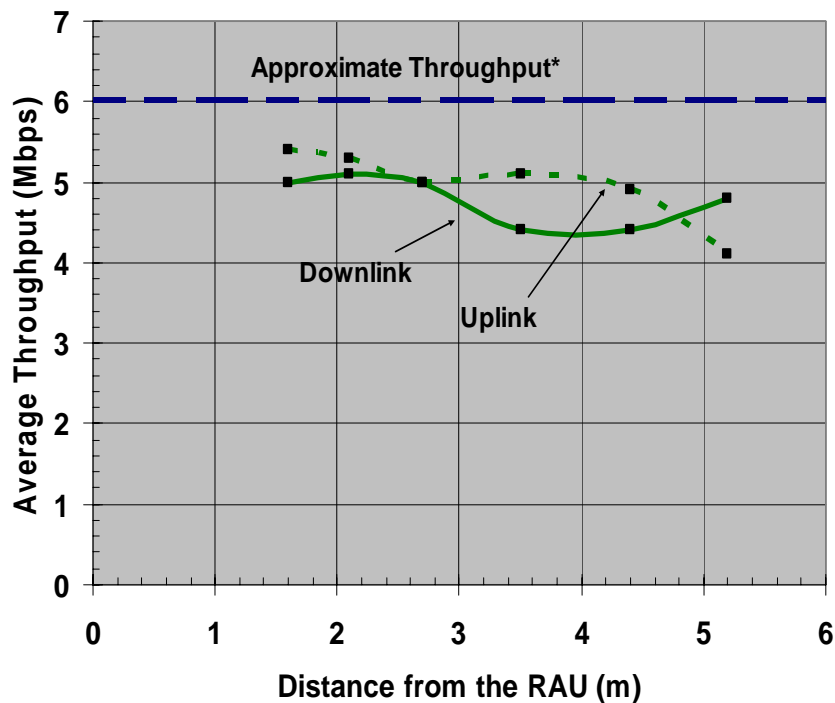

Throughput measurement for IEEE 802.11g

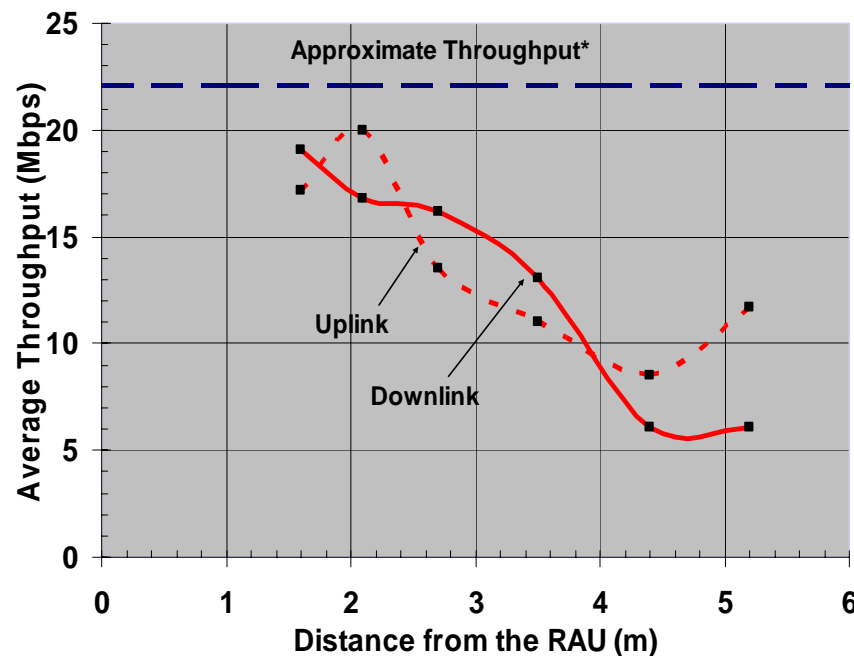

\* Approximate Throughput: 6Mbps for IEEE 802.11b, 22Mbps for IEEE 802.11g [8]

## CONCLUSIONS

- ❑ Two-antenna RAU:
  - range predictions carried out using link budget analysis
  - maximum range of **23m** for *IEEE 802.11b* and **7m** for *IEEE 802.11g* calculated
- ❑ Performance of RoF link characterised:
  - predicted signal strength using link budget verified against measured signal strength at different distances
  - average throughputs of **5.2Mbps** for *IEEE 802.11b* and **20Mbps** for *IEEE 802.11g* achieved
- ❑ Successfully demonstrated:
  - transmission of a WLAN signal (*IEEE 802.11b/g*) over the RoF link - **streaming video**
  - complete radio coverage of a **6.2m X 5.6m** indoor office room
- ❑ Results validate implementation of a prototype RoF system in a ‘real’ office environment using inexpensive components: *850nm VCSELs, pre-installed MMF, Omni-directional RF antennas*

## FUTURE WORK

- ❑ Effect of using different MMF combinations (for DL and UL paths), on range and throughput for the current system demonstrator
- ❑ Single Antenna RAU performance
  - Range and throughput performance for transmission of WLAN signals over the optical and wireless link
- ❑ Set- up using multiple RAUs being driven by a single access point
- ❑ Use of EAMs in the RAU instead of a PD-VCSEL combination needs to be experimentally verified

## ACKNOWLEDGEMENTS

**The presented work has been carried out as a part of an Anglo-French collaboration called ROSETTE - Radio Optical Systems Engineering for Transmanche Telecom - partly funded by the European Union**

**We wish to thank:**

- Our collaborators, IEMN Lille, France and IEMN Valenciennes, France
- Mr. Rob Davis, Photonics Group, University of Kent



*THANK YOU!*

- [1] Carlsson C., Martinsson H., Larsson A., Alping A., “High Performance Microwave Link Using a Multimode VCSEL and High-Bandwidth Multimode Fiber”, Int. Topical Mtg. on Microwave Photonics, MWP’01, Technical Digest, Jan. 2002, pp. 81-84
- [2] Schuh R.E., Alping A., Sundberg E., “Penalty-free GSM-1800 and WCDMA radio-over-fibre transmission using multimode fibre and 850nm VCSEL”, Electronics Letters, Vol. 39, No.6, March 2003, pp. 512-514
- [3] Hartmann et. al, “Low-cost multimode fibre-based wireless lan distribution system using uncooled, directly modulated DFB laser diodes”, Proceedings of the European Conference on Optical Communication (ECOC) 2003, Vol. 3, pp. 804-805
- [4] ASH Transceiver’s Guide, [www.rfm.com/products/tr-des24.pdf](http://www.rfm.com/products/tr-des24.pdf), pp.51
- [5] Theodore S. Rapaport, Sandip Sandhu, “Radio-Wave propagation for emerging wireless personal-communication systems”, IEEE Antennas and Propagation Magazine, Vol. 36, No. 5, October 1994, pp. 14-23
- [6] IEEE Std. 802.11b-1999, <http://standards.ieee.org/getieee802>
- [7] IEEE Std. 802.11g-2003, <http://standards.ieee.org/getieee802>
- [8] “Capacity, Coverage, and Deployment Considerations for IEEE802.11g”, Cisco Systems White paper

